

MUTOH

OPERATION MANUAL

Full-Color Inkjet Printer

ValueJet

VJ-1324

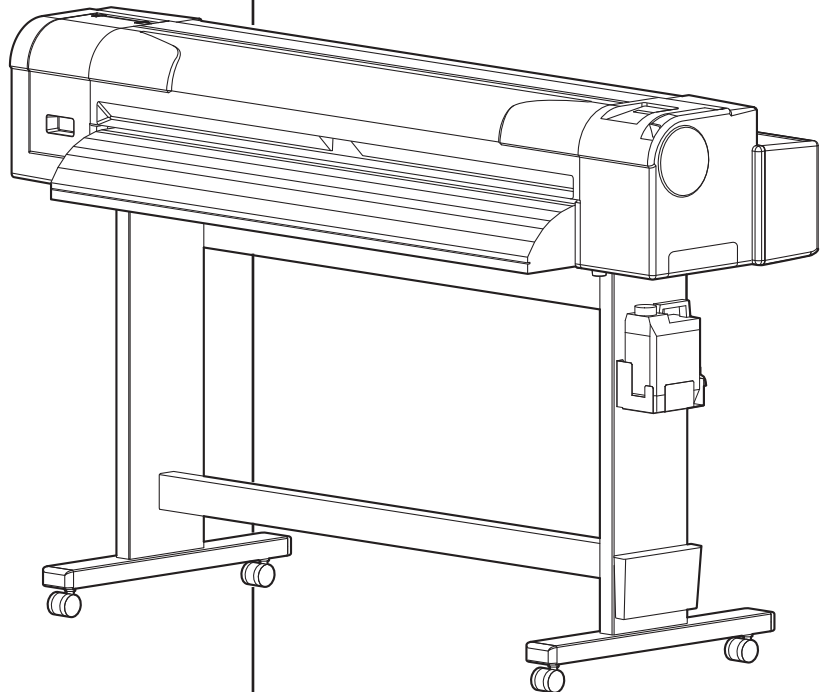

Read This Manual Before Using The
Printer.

Rev.

VJ1324E-A-04

Important Notice

1. For Users in Europe



The CE marking is a mandatory European marking for certain product groups to indicate conformity with the essential health and safety requirements set out in European Directives.

By affixing the CE marking, the manufacturer, his authorized representative, or the person placing the product on the market or putting it into service ensures that the item meets all the essential requirements of all applicable EU directives and that the applicable conformity assessment procedures have been applied.

2. For Users in the United States

This equipment has been tested and found to comply with the limits for a Class A digital device, pursuant to Part 15 of the FCC Rules.

These limits are designed to provide reasonable protection against harmful interference when the equipment is operated in a commercial environment.

This equipment generates, uses, and can radiate radio frequency energy and, if not installed and used in accordance with the instruction manual, may cause harmful interference to radio communications.

Operation of this equipment in a residential area is likely to cause harmful interference in which case the user will be required to correct the interference at his own expense.

3. Trademark Mentioned in this Manual

- MUTOH, ValueJet, VJ-1324, MH-RTL are registered trademarks or product names of MUTOH INDUSTRIES LTD.
- Windows7, WindowsVista, Windows XP are registered trademarks or product names of Microsoft Corporation.
- Other company and product names may be registered trademarks or product names.

NOTE

- No part of this product or publication may be reproduced, copied, or transmitted in any form or by any means, except for personal use, without the permission of MUTOH INDUSTRIES LTD.
 - The product and the contents of this publication may be changed without prior notification.
 - MUTOH INDUSTRIES LTD. has made the best efforts to keep this publication free from error, but if you find any uncertainties or misprints, please call us or the shop where you bought this equipment.
 - MUTOH INDUSTRIES LTD. shall not be liable for any damages or troubles resulting from the use of this equipment or this manual.
-

Warranty Limitations

1. MUTOH INDUSTRIES LTD. warrants part repair or replacement as a sole measure only if a failure is found in the system or in the materials and workmanship of the product the seller produced. However, if the cause of failure is uncertain, decide the action after due mutual consultation.
2. The warranty shall not apply to any direct or indirect loss, or compensation for the loss due to the product that has been subject to misuse, neglect, or improper alternation.

About this Manual

1. Contents of the Manual

There are three manuals for this product.

Installation manual

Explains operating procedures along with unpacking, installation and preparation before use.

Operation Manual (this manual)

2. Purpose and Target Readers

This manual explains preparations before use and operation procedures for MUTOH Full Color Ink Jet Printer VJ-1324.

This manual is prepared for the owners and operators of this printer.

Before using this printer, fully understand the contents and directions in this manual.

3. Manual Configuration

Section	Description
1 Safety instructions	This chapter explains the installation of this printer, warning terms that operators need to know, caution items and warning labels on the printer main unit.
2 Product overview	This chapter explains the features of the printer along with the names and functions of each part.
3 Before using	This chapter explains necessary steps before using the printer.
4 Handling the printer	This chapter explains how to handle the printer.
5 Panel setup menu	The section explains the Setup menu of the printer.
6 Maintenance	This chapter describes daily maintenance of the product.
7 Troubleshooting	This chapter describes possible troubles during the use of this product and countermeasures.
8 Appendix	This chapter describes specifications and included components with this printer.

NOTE

- "1 Safety instructions" to "4 Handling the printer" must be read before using the printer.
- Read "5 Panel setup menu" through "8 Appendix" as necessary.

4. Manual Notation

This section explains general cautions that must be followed in order to use this printer safely.







Warning	Meaning
 WARNING	Used for dangerous situations where death or serious injury may be caused.
 CAUTION	Used for dangerous situations that may cause slight or medium injury, or when all or parts of products are damaged.
 NOTE	It is used for special cautions and for information that needs to be emphasized.
 TIP	Indicates useful tips for operating or understanding the printer.
	Indicates "prohibited" operations.
	Indicates required operations.
	Indicates reference pages in this manual.

TABLE OF CONTENTS

1 Safety instructions

1.1	Types and meanings of warnings	16
1.2	Important safety instructions	17
1.3	Warning labels	21
1.3.1	Handling the warning labels.	21
1.3.2	Location and type of warning labels	22
1.4	Operating Instruction Labels	23
1.4.1	Cautions on Handling the Operating Instruction Labels	23
1.4.2	Locations and Types of Operating Instruction Labels	23

2 Product overview

2.1	Features	26
2.2	Names of parts and functions.	27
2.2.1	Front section	27
2.2.2	Rear section.	28
2.2.3	Operation panel	29
2.2.4	Ink level indicator	33
2.2.4.1	Estimated Ink level graphic	34
2.3	Printer status	35
2.3.1	Normal	35
2.3.2	Setup menu display	35
2.3.3	Changing printer status	35

3 Before using

3.1	Power cable connection	38
3.2	Turning the power ON/OFF	42
3.2.1	Turning the power ON	42
3.2.2	Turning the power OFF	43
3.3	Installing ink cartridges.	45
3.3.1	Installing 220ml ink cartridges	47
3.3.2	Installing high capacity pack adapters (option)	51
3.3.3	When using the high capacity pack adapter for the printer whose ink is charged for the first time	55

3.4	Loading media	56
3.4.1	Loading roll media	56
3.4.2	Setting Roll Media	59
3.4.3	Setting the User Type Setting	63
3.5	Test print.	65
3.5.1	Nozzle check	68
3.5.2	Mode print	69
3.5.3	Setup print	70
3.5.4	Palette print	71
3.5.5	Color Verify	72
3.6	Adjust Print.	87
3.6.1	Standard Adjust Print.	88
3.6.1.1	Standard Confirmation Pattern	89
3.6.1.2	Standard Rough Adjustment Pattern	93
3.6.1.3	Standard Micro Adjustment Pattern	96
3.6.2	Custom Adjustment Pattern.	99
3.6.2.1	Custom Confirmation Pattern	100
3.6.2.2	Custom Rough Adjustment Pattern	105
3.6.2.3	Custom Micro Adjustment Pattern	108
3.6.2.3.1	Adj. PatternALL.	108
3.6.2.3.2	Each Adjust Patterns	111
3.7	Connecting the printer to PC	114
3.7.1	System requirements.	114
3.7.2	Preparing cables	114
3.7.3	Connecting a network interface cable	115
4	Handling the printer	
4.1	Print flow chart.	118
4.2	Media.	119
4.2.1	Media type	119
4.2.2	Cautions on handling media	120
4.2.3	Precaution on storing media	120
4.2.4	Printing area	121
4.2.5	Head height adjustment.	121
4.2.5.1	When raising the print head	122
4.2.5.2	When returning the print head to the original position.	124
4.2.6	Media feed compensation	126
4.3	Menu setups on the operation panel	132
4.3.1	Menu setup procedure.	132
4.3.2	Panel setup menu overview	134
4.4	Operating from the operation panel.	135
4.4.1	Feeding media	135
4.4.2	Stopping printing operation	136
4.4.3	Cutting media	137
4.4.4	Cutting media manually	138
4.4.5	Changing and confirming settings while printing	139
4.4.5.1	Procedure for changing and confirming settings while printing	139

4.4.5.2	Settings that can be changed or confirmed while printing	140
4.4.6	Pausing printing	141
4.4.7	Start Printing during Warm up	142
4.4.8	Normal Display while Printing	143
4.5	Using spectrophotometer (SPECTROVUE VM-10)	145

5 Panel setup menu

5.1	Setup menu	158
5.1.1	User Type menu	160
5.1.1.1	User Type menu	160
5.1.1.1.1	Print Mode menu	162
5.1.1.1.2	Effect menu	164
5.1.1.1.3	Adjust Print menu	165
5.1.1.1.4	Dist.Adj menu	167
5.1.1.1.5	Pre-heater menu	169
5.1.1.1.6	Platen heater menu	170
5.1.1.1.7	Dryer menu	171
5.1.1.1.8	Vacuum Fan menu	171
5.1.2	Spitting menu	172
5.1.2.1	Spitting Pass count menu	173
5.1.3	Side Margin menu	175
5.1.4	Media Initial menu	176
5.1.5	Media Width menu	177
5.1.6	Output Mode menu	178
5.1.6.1	Ink Drying Time Menu	178
5.1.7	Method of Cut menu	179
5.1.7.1	Cut Pressure menu	179
5.1.8	Origin menu	180
5.1.9	Prev. Stick menu	182
5.1.10	StandbyHeating menu	182
5.1.11	Head Travel menu	183
5.1.12	Multi Strike menu	183
5.1.13	Strike Wait menu	184
5.1.14	Slant Check menu	184
5.1.15	Auto Cleaning menu	185
5.1.15.1	Idle Auto Cleaning	185
5.1.15.2	Printing Mode Auto Cleaning	186
5.1.15.3	Pre-printing Mode Auto Cleaning	186
5.1.16	Ink Status menu	187
5.1.16.1	SmartChip menu	187
5.1.17	Roll Length menu	187
5.1.17.1	Roll Length menu	188
5.1.18	Longstore menu	188
5.1.19	CR Maintenance menu	189
5.1.20	Initialization menu	189
5.1.21	Life Times menu	190
5.1.22	IP Address menu	190
5.1.23	Subnet Mask menu	191
5.1.24	Gateway menu	191
5.1.25	Header Dump menu	192

5.2	Test Print Menu	193
5.3	Cleaning menu	194
5.4	Menu Option menu	195
5.5	Version menu	198
5.6	Sleep Mode menu	199
5.6.1	Timer Setting menu	200
5.6.2	Sleep Mode Start menu	201
5.7	Display menu	202
5.7.1	Language menu	202
5.7.2	Temperature menu	202
5.7.3	Length menu	203
5.7.4	Remain Ink menu	203
5.8	Job Status Menu	204
 6 Maintenance		
6.1	Replacing consumable components	206
6.1.1	Replacing ink cartridges	206
6.1.2	Replacing Roll Media	211
6.1.3	Replacing Cutter	214
6.2	Cleaning the printer	222
6.2.1	Cleaning the outer case	223
6.2.2	Cleaning the inside of the printer	224
6.2.3	Head cleaning	226
6.2.4	Cleaning the cleaning wiper	227
6.2.5	Cleaning around the print head	232
6.3	Disposal of waste fluids	239
6.4	Moving or transporting the printer	241
6.4.1	Moving the printer	241
6.4.2	Transporting the printer	243
 7 Troubleshooting		
7.1	Malfunctions and failures	246
7.1.1	Problems in installation and introduction	246
7.1.2	Cannot print at all	246
7.1.3	Media-related troubleshooting	248
7.1.4	Printing-related troubleshooting	250
7.2	Error messages	253
7.2.1	Status messages	253
7.2.2	Message type error display and remedies	254
7.2.3	Error requiring restart	258
7.3	The media is jammed	259

8 Appendix

8.1 Product specifications	264
8.1.1 Printer specifications	264
8.2 Interface specification	266
8.2.1 Network interface specification	266
8.3 Options/Supply list	267

9 Setup menu diagram

1 Safety instructions

This chapter explains the installation of this printer, warning terms that operators need to know, caution items and warning labels on the printer main unit.





- **When installing and operating this printer, be sure to follow the directions and warnings in this book.**
-

1.1 Types and meanings of warnings

The warnings in the Operation Manual and the warning labels attached to the printer are categorized into three stages.













Understand the meanings of the following warning terms and follow the contents (instructions) in this manual.

Warning	Meaning
 WARNING	Used for dangerous situations where death or serious injury may be caused.
 CAUTION	Used for dangerous situations that may cause slight or medium injury, or when all or parts of products are damaged.
NOTE	Used for special cautions and for information that needs to be emphasized.

1.2 Important safety instructions

This section explains general cautions that must be followed in order to use this printer safely.

WARNING

-  Do not install this printer in the following places.
It may cause an injury if the printer falls down.
 - On a shaky stand
 - Slanting location
 - Places where vibration of other machines etc. is transmitted
-  Do not step on this printer or place heavy things on top of it.
It may cause an injury if the printer falls down.
-  Do not block the vent by covering the printer with cloths, such as a blanket or tablecloth.
If the vent is blocked, heat may accumulate inside the printer and it may cause fire.
-  Do not install the printer where it is humid or dusty.
It could lead to an electric shock and fire.
-  Do not use a damaged power cable.
It could lead to an electric shock and fire.
-  Do not pull out or insert the power plug with a wet hand.
This could lead to an electric shock.
-  Do not connect an earth wire to the following places.
 - Gas pipes
There is a possibility of ignition and explosion.
 - Earth wire of telephone cables and lightning rods
Heavy current might flow whenever lightning strikes.
 - Water pipe and faucet
The earth might not work if a plastic pipe is connected in the middle of the metal pipe.
-  Do not insert or drop metal or flammable objects into the printer through openings such as a vent.
It could lead to an electric shock or fire.
-  Do not spill flammable liquid on the platen.
This could lead to a fire.
-  Do not place any combustible materials on the platen while the heater is working.
There may be a risk of fire.
-  If foreign substances or liquids such as water entered the printer, do not use the printer as it is.
It could lead to an electric shock or fire.
Immediately turn OFF the power switch, disconnect the power plug from the electric socket, and contact your local MUTOH dealer.
-  Wire the various cords as directed in the Operation Manual.
Mistaken wiring could cause fire.
-  Be sure to use the specified power cable.
Using power cables other than the specified can cause an electric shock or fire.



Make sure to use only the specified power supply (AC 100 V to 120 V or AC 220 V to 240 V).
If a power supply other than the specified voltage is used, it could cause an electric shock and fire.



Take power for the printer directly from the power socket (AC 100 V to 120 V or AC 220 V to 240 V).
Do not use multiple plugs on the same socket.
This could generate heat and might cause fire.



Be sure to use a dedicated power socket with earth wire for the power supply, and connect it to the earth wire.
If the earth wire is not connected, an electric shock or fire may occur.



The waste fluid from the printer falls under the category of waste oil (waste ink) of industrial waste (out of the 19 items of general waste from business activities).
You are obligated to properly dispose of waste fluid in compliance with Wastes Disposal and Public Cleansing Act and local ordinances.
Delegate disposal to an industrial waste disposal contractor.

**CAUTION**

Pay attention to the following points when handling power cable.

- Do not tamper with the power cable.
- Do not put heavy objects on the power cable.
- Do not bend, twist or pull the power cable by force.
- Do not route the power cable near heating appliances.



Pay attention to the following points when handling the power supply plug.
Any mishandling of the power cable could cause a fire.

- Make sure that no foreign substances such as dust etc. are stuck to the power plug.
- Make sure that the power plug is firmly inserted to the edge of the power socket.



When handling ink cartridges, pay attention so that ink does not get into your eyes or stick to your skin.
If ink gets into your eyes or sticks to your skin, immediately wash it off with water.
Failing to do so might cause irritation or light inflammation of eyes.
In case of any abnormality, consult a physician immediately.



Do not disassemble ink cartridges.
If disassembled, there is a possibility that ink might come into contact with eyes or skin.



Do not operate the media loading lever during the initial operation or printing.
The print head portion may touch the pressurizing roller portion, and cause a malfunction.



Do not use volatile solvents such as thinner, benzene, or alcohol.
These solvents could cause damage to the paint.



Do not touch the media guide while printing.
The media guide becomes very hot and you could burn yourself.



Do not touch the media feed slot, platen, and media guide while the heater is working.
The media feed slot, platen, and media guide become very hot and you could burn yourself.



Be careful that no moisture enters the printer.
There is a possibility that the electric circuit inside the printer is short circuited.



Do not open covers attached using screws under any circumstances.
This may cause an electric shock or a malfunction.



When cleaning the cleaning wiper,

- Do not touch the cleaning wiper and head cap unit.
Head cleaning may not be performed correctly because of oil from your hands.
- Make sure to wipe the print head using the cleaning stick.
A wet cleaning stick may cause the print head to clog.
- Do not reuse the cleaning stick.
The attached dust, etc may damage the print head.



When cleaning around the print head,

- Do not touch the nozzles of the print head.
Doing so may damage the print head.
- Do not touch the tip of the cleaning stick.
The print head may be damaged because of oil from your hands.
- Never put water, etc on the tip of the cleaning stick.
Doing so may damage the print head.
- Do not reuse the cleaning stick.
The attached dust, etc may damage the print head.



Do not slant the printer, prop it against a wall or turn it upside down.

There is a possibility that ink inside the printer may leak.
Moreover, normal operation after shifting (to these positions) cannot be guaranteed.



Unpacking or moving this printer must be done by the following number of people.

- VJ-1324: more than three persons



Installing the dedicated stands on the printer must be done by the following number of people.

- VJ-1324: more than three persons



When installing the dedicated stands, make sure to turn OFF the printer and unplug the power cable.
There may be a risk of electric shock.



When you do not use the printer for a long period, make sure to pull out the power plug from the power socket for safety.



Make sure to connect an earth wire to the earth connection that meets the following standards.

- Earth terminal of power socket
- Earth wire with copper plate which is buried at 650 mm or more, deep in the ground.



Before operation, make sure to read the Safety Data Sheet (SDS).



Ventilate the workplace.

Not doing so may make you feel sick or may lead to a fire.



Right after printing, the media guide becomes very hot.

Allow the media guide to cool down before the next operation.



When loading the roll media, place it on a flat surface such as a desk.

If the roll media is loaded with the scroller up, the scroller may be damaged.



Pay attention to the following points when cutting roll media.

Mishandling the razor blade may cause a cut on your finger or hand.

- When you hold media, do not place your finger on the media cut groove.
- Move the razor blade along the media cut groove.



When cleaning the areas other than the wiper, make sure to turn OFF the power and unplug the power cable.



Move the printer maintaining a horizontal position.

1.3 Warning labels

This section explains the handling of warning label, pasting location and types.

Warning labels are attached to parts of the printer that need special caution.

Understand the locations and the descriptions of the danger associated with each label before operating the printer.

1.3.1 Handling the warning labels

When handling the warning labels, be careful about the following points.

NOTE

- Check whether all the warning labels can be read.
If the letters or illustrations on the label are not clear, remove the dirt from the label.
 - Use cloth, water and mild detergent for removing dirt from the warning label.
Avoid either organic solvents or gasoline.
 - It is necessary to replace the labels if they are damaged, lost or illegible.
If the warning labels have to be replaced, contact your local MUTOH dealer.
-

1.3.2 Location and type of warning labels

Pasting locations of the warning labels are shown in the following figure.

(1) Front

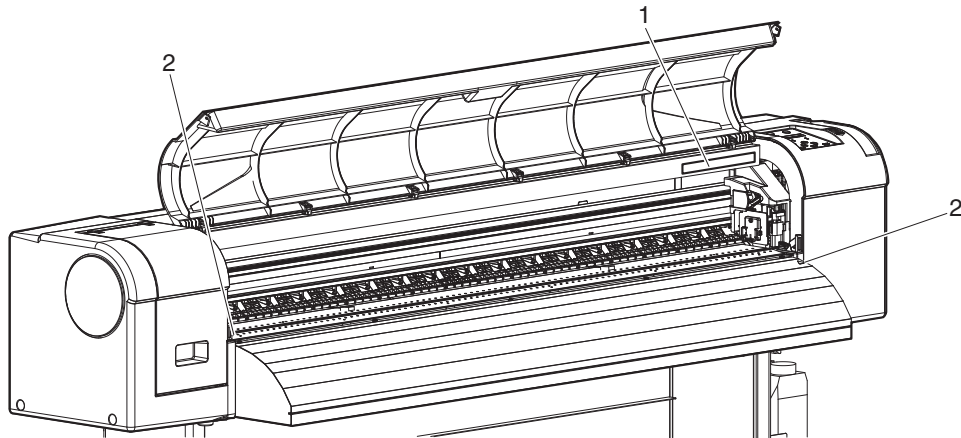

(2) Rear

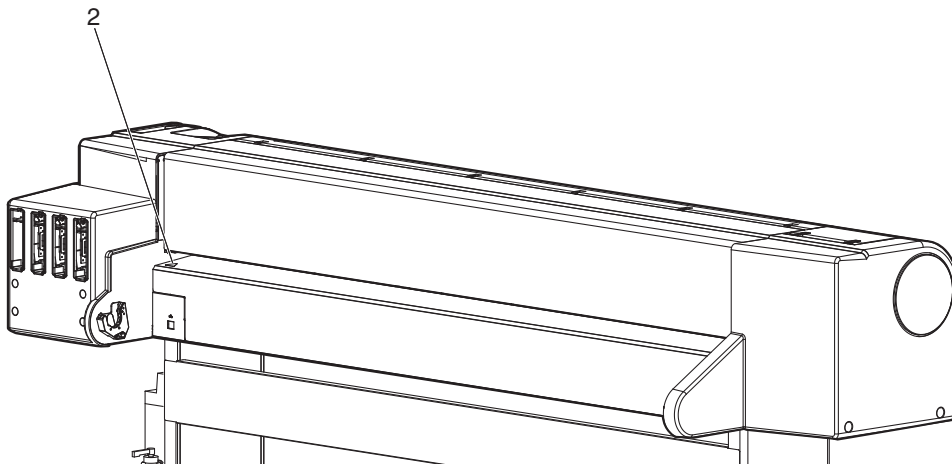

No.	Types of warning labels
1	
2	

1.4 Operating Instruction Labels

This section explains the handling of operating instruction labels and their locations and types. This printer has some operating instruction labels with simplified operation procedures where special attention is required during operation.

Make sure to fully understand the locations and contents of the labels before operating the printer.

1.4.1 Cautions on Handling the Operating Instruction Labels

When handling the operating instruction labels, note the following.



NOTE

- Check if all of the operating instruction labels can be read.
If the letters or illustrations on the label are not clear, remove the dirt from the label.
- When cleaning the operating instruction labels, use a cloth, water, and mild detergent.
Avoid either organic solvents or gasoline.
- It is necessary to replace the operating instruction labels if they are damaged, lost or unreadable.
If the operating instruction labels have to be replaced, contact your local MUTOH dealer.

1.4.2 Locations and Types of Operating Instruction Labels

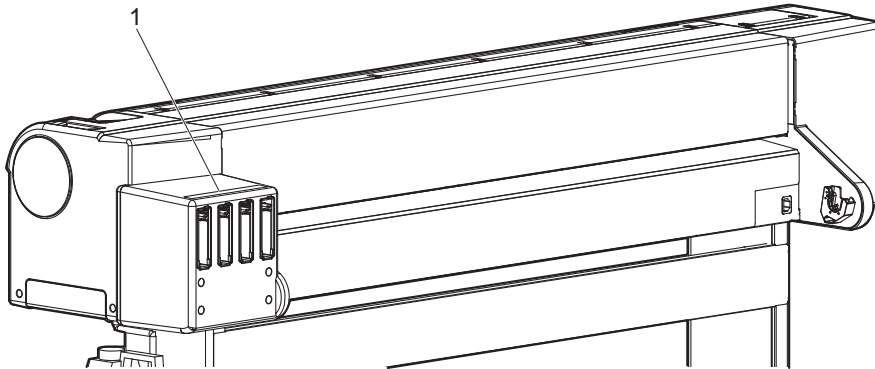
Locations of the operating instruction labels are shown in the following figure.



No.	Types of the operating instruction labels	Reference
1		 6.1.1 Replacing ink cartridges

2 Product overview

This chapter explains the features of this printer along with the names and functions of each part.

2.1 Features

This section explains the main features of the printer.

(1) High-speed output

The new print head has realized high-speed output.
For VJ-1324, the printing width of 1,361mm has been made possible.

(2) Wide variety of compatible media

The height of the print head is adjustable to two levels, which has made it possible to print on various paper with the width of 0.08mm to 1.3mm.

(3) Vibrant color reproduction

4 colors of ink are used for printing in order to reproduce sharp and vivid colors.
High capacity ink cartridges of 220ml with the dedicated IC chip (1000ml Inkpacks are also usable with the dedicated adapter) are adapted.
Ink consumption amount can be controlled, greatly improving productivity.
Use of variable dots can also improve color reproduction.

(4) Adapted multi-heater

The media heating system developed by LamiLess series has been arranged for solvent ink.
Pre-heater, Platen heater, and After heater have been installed to improve ink settlement and drying speed of solvent ink on media.

(5) Effective use of media

A JOG feature is provided to allow setting of the print starting position as required.
Printing can be performed on media that has already been printed on. This allows effective use of left margins.

(6) Optional spectrophotometer is available

A compact and light spectrophotometer (SPECTROVUE VM-10) is provided to measure visible light ranging from 400nm to 700nm. This can be used as a colorimeter for color calibration and profiling. (The conditions of use for color calibration and profiling depend on your RIP software.)
Install spectrophotometer on the print head to measure the color target automatically.

2.2 Names of parts and functions

This section explains the names and functions of each part.

2.2.1 Front section

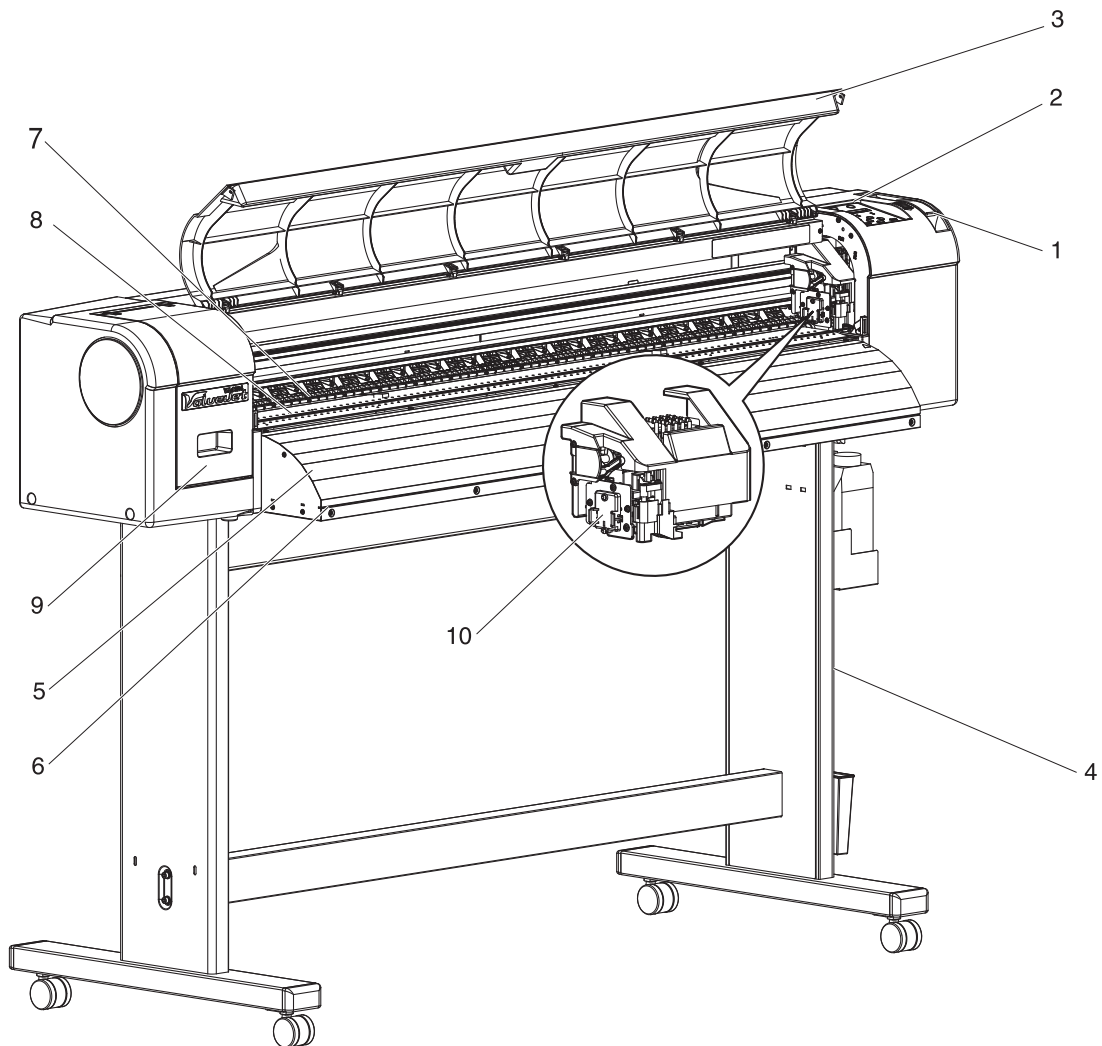

No.	Name	Function
1	Media loading lever	Used for fixing or releasing media.
2	Operation panel	Operation condition setting, printer display and various function settings are performed.
3	Front cover	Used for preventing a user from coming in contact with the driving mechanism during the printer operation. Opened and closed when media is set or jammed. It is normally closed.
4	Stand	Used when installing the printer on a flat floor.
5	Media guide	Used for feeding media smoothly when the media is set or printed.

No.	Name	Function
6	Media cut groove	Used to cut media straight.
7	Pressurizing rollers	Installed inside of the front cover. Press and hold the media when printing.
8	Platen	Installed inside of the front cover. Stabilizes the print side of the media.
9	Maintenance cover	Used to prevent the user from touching the inner mechanical section. Open and close in the following cases. <ul style="list-style-type: none"> • When cleaning the cleaning wiper • When cleaning around the print head. • When replacing the cutter It is normally closed.
10	Connector	Used to install spectrophotometer (SPECTROVUE VM-10).

2.2.2 Rear section

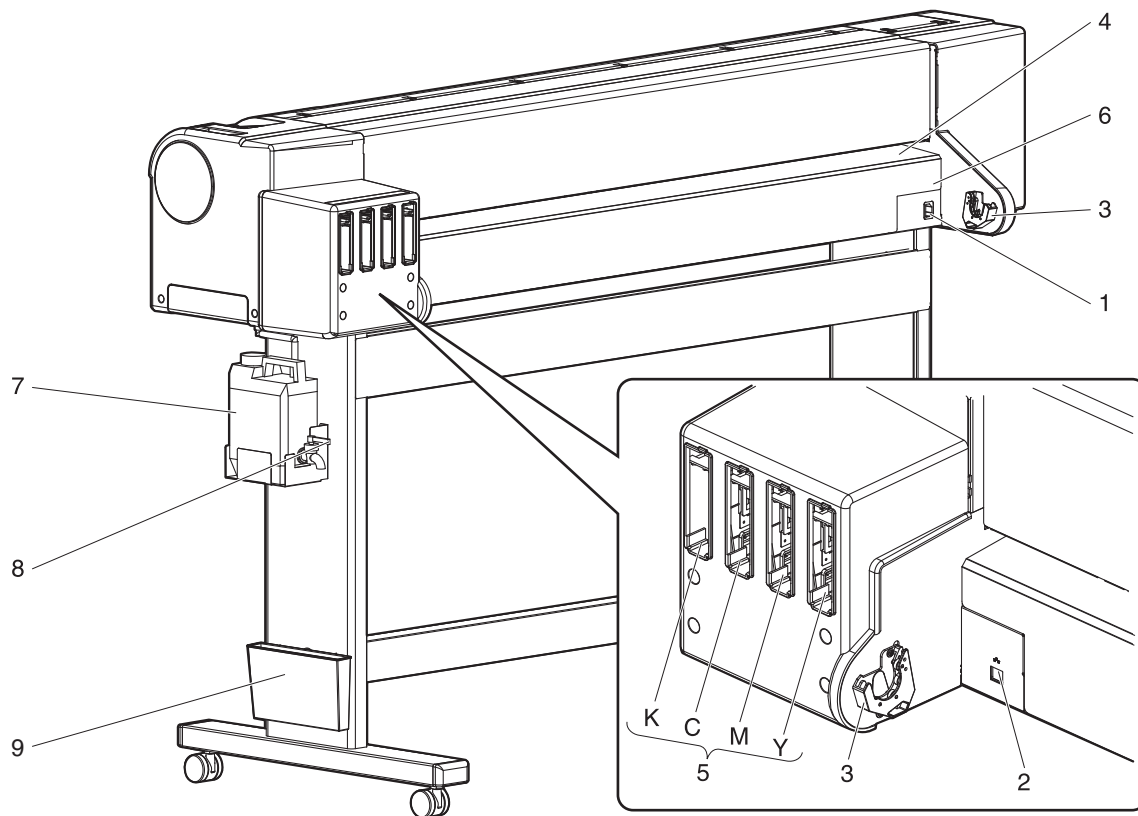

No.	Name	Function
1	AC inlet	Used for connecting the power cable.
2	Network interface cable connector	Connects a network interface cable.
3	Scroller holder	Set the scroller here when using the roll media.
4	Media feed slot	Used for feeding media.

No.	Name	Function
5	Ink cartridge slot	Insert the ink cartridge.
6	Media guide	Used for feeding media smoothly when the media is set or printed.
7	Waste fluid tank	Used for collecting waste ink discharged from the printer.
8	Waste fluid valve	Open and close when discharging the waste fluid from the waste fluid tank. It is normally closed.
9	Book holder	Quick reference etc can be stored.

2.2.3 Operation panel

Used to set the operating conditions, to display the status of the printer, and to set various functions. Names of each operation key and status display along with the functions are explained.

TIP

- Refer to the following for details regarding the operation method of the operation panel.
- When performing menu setting from the operation panel: [4.3 Menu setups on the operation panel](#)
- When performing various operations in the operation panel: [4.4 Operating from the operation panel](#)

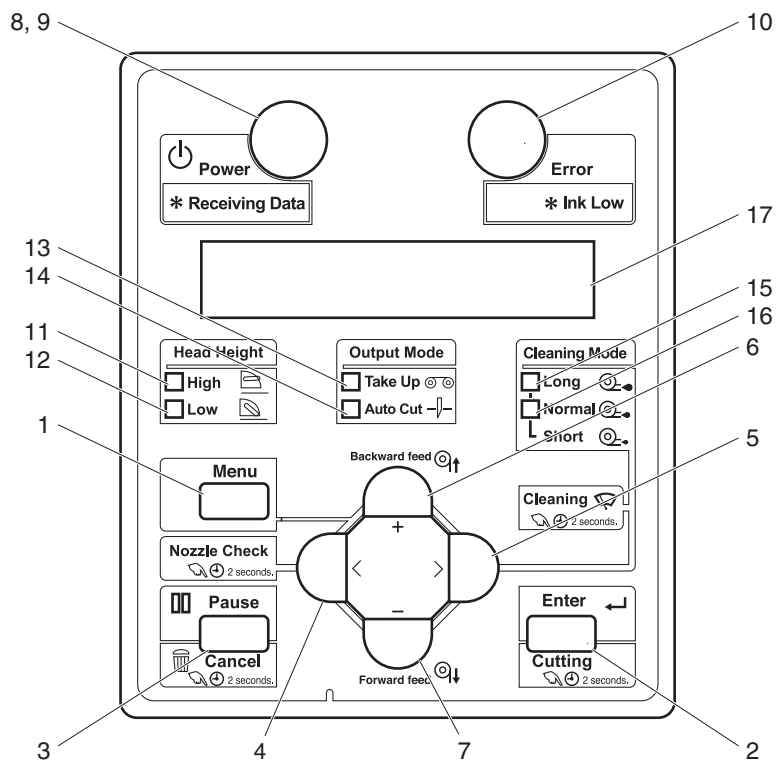

(1) Operation keys

NOTE

- The operation keys are assigned with different functions and names depending on printer status (Normal or Setup menu display).

For details about printer status, refer to "2.3 Printer status".

No.	Name	Normal	Setup menu display
1	[Menu] key	Shifts to the Setup menu.	Shifts from Setup menu display to Normal.
2	[Enter] key	Restarts printing when the printing is suspended.	<ul style="list-style-type: none"> Select the menu to be set, and shifts to the next hierarchy. The setting is determined and saved.
	[Cutting] key	Cuts the media when pressed for more than two seconds.	—
3	[Pause] key	Pauses printing.	—
	[Cancel] key	<ul style="list-style-type: none"> When printing: When pressed for more than two seconds, forcefully terminates printing and deletes one file of the remaining data. When receiving or analyzing data: When pressed for more than two seconds, deletes the data already received and analyzed. 	<ul style="list-style-type: none"> Returns to the previous menu hierarchy. Changes made in the setting are discarded. Shifts from Setup menu display to Normal.
4	[<] key	—	—
	[Nozzle Check] key	Press and hold this key for two seconds or more to perform Nozzle Check printing.	—
5	[>] key	<ul style="list-style-type: none"> Sets Cleaning Mode. The lamp of Cleaning Mode that you set lights up in green. 	Down the menu level in the directory tree.
	[Cleaning] key	When pressed for more than two seconds, cleaning starts.	—
6	[Backward↑] key	Media is fed in the reverse direction.	—
	[+] key	—	<ul style="list-style-type: none"> Changes to the previous item in the displayed menu. The setting is changed to the reverse direction. The numeric value is increased during numerical input.
7	[Forward↓] key	Media is fed in the forward direction.	—
	[-] key	—	<ul style="list-style-type: none"> Changes to the previous item in the displayed setting. The setting is changed to the forward direction. The numeric value is decreased during numerical input.
8	[Power] key	Turns the printer ON and OFF.	Turns the printer ON and OFF.

(2) Display section

No.	Name	Color	Status	Description
9	Power lamp	Blue	Lamp ON	Power ON.
			Lamp blinks	<ul style="list-style-type: none"> Receiving and analyzing the data. Performing media initial operation.
			Lamp OFF	Power OFF.
10	Error lamp	Orange	Lamp ON	An error has occurred. Error content is displayed on the LCD.
			Lamp blinks	The remaining amount of ink is low.
			Lamp OFF	There is no error.
11	High lamp	Green	Lamp ON	The head height is set to High.
			Lamp OFF	The head height is set to Low.
12	Low lamp	Green	Lamp ON	The head height is set to Low.
			Lamp OFF	The head height is set to High.
13	Take Up lamp	Green	Lamp ON	Media ejection mode is set to "Take-up".
			Lamp OFF	Media ejection mode is set to "Off" or "Auto cut".
14	Auto Cut lamp	Green	Lamp ON	Media ejection mode is set to "Auto cut".
			Lamp OFF	Media ejection mode is set to "Off" or "Take-up".
15	Long lamp	Green	Lamp ON	<ul style="list-style-type: none"> Cleaning mode is set to Long. When the Normal lamp is also on, Cleaning mode is set to Short.
			Lamp OFF	Cleaning Mode is set to Normal.
16	Normal lamp	Green	Lamp ON	<ul style="list-style-type: none"> Cleaning Mode is set to Normal. When the Long lamp is also on, Cleaning mode is set to Short.
			Lamp OFF	Cleaning Mode is set to Long.
17	LCD display section	—	—	Displays operation status of the printer or an error message.

TIP

When an error requiring a restart (fatal malfunction for the printer operation) occurs, all lamps blink with an alarm.

🔧 7.2.3 Error requiring restart

If the error persists even when the malfunction is fixed, contact your local MUTOH dealer.

2.2.4 Ink level indicator

When the “Remain Ink menu” on Display menu is set to “On”, the ink level indicator that describes the ink or ink cartridge status is displayed on LCD monitor.

☞ 5.7 Display menu

☞ 5.7.4 Remain Ink menu

- In the normal operation
☞ 2.3.1 Normal
- During printing
- To display ink or cartridge errors
☞ 7.2.2 Message type error display and remedies

The indicator and the corresponding Ink color labels are shown below.





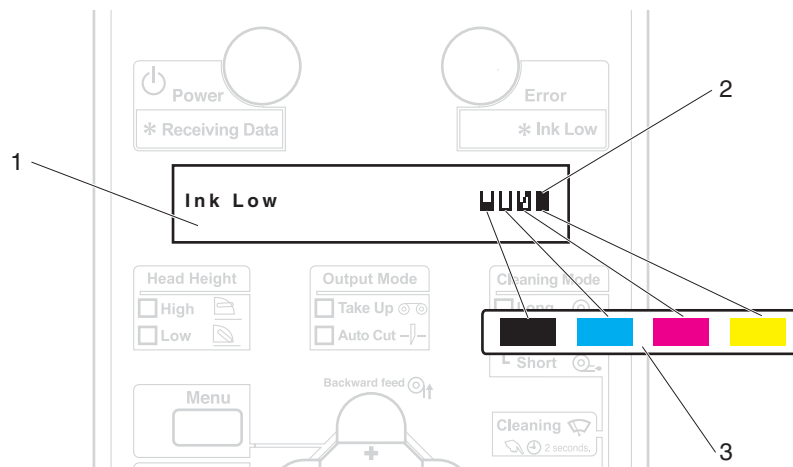



NOTE

- The ink color labels are attached to the top of the ink cartridge slots.



No.	Name
1	LCD display section
2	Ink level indicator
3	Ink color label(K, C, M, Y)

2.2.4.1 Estimated Ink level graphic

No.	Indicator to display	the conditions of ink/cartridges
1		Remaining ink amount : More than 80%, less than 100%
2		Remaining ink amount : More than 60%, less than 80%
3		Remaining ink amount : More than 40%, less than 60%
4		Remaining ink amount : More than 20%, less than 40%
5		Remaining ink amount : Less than 20%
6		Ink Near End
7		Ink End
8		No cartridge

2.3 Printer status

This section explains printer status.

2.3.1 Normal

Printing is possible when media is loaded.

The various functions for printing can be performed on the operation panel.

2.3.2 Setup menu display

Various settings regarding printing can be made from the operation panel.

The various functions for printing can be performed on the operation panel.

Display contents in the LCD monitor of the operation panel are as follows.

2.3.3 Changing printer status

Follow the procedure below and change printer status.

(1) Normal → Setup menu display

Press the [Menu] key on the operation panel when the printer is Normal.

- "Menu 1: Setup>" is displayed on the operation panel and the display shifts to the Setup menu.

NOTE

- For details regarding the Setup menu, refer to "[4.3 Menu setups on the operation panel](#)".

(2) Setup menu display → Normal

When the printer is at the Setup menu display, perform either of the following operations to shift the operation panel to the Normal display.

- Press the [Cancel] or [Menu] key on the operation panel.
- In the Setup menu, leave the keys untouched for three minutes.

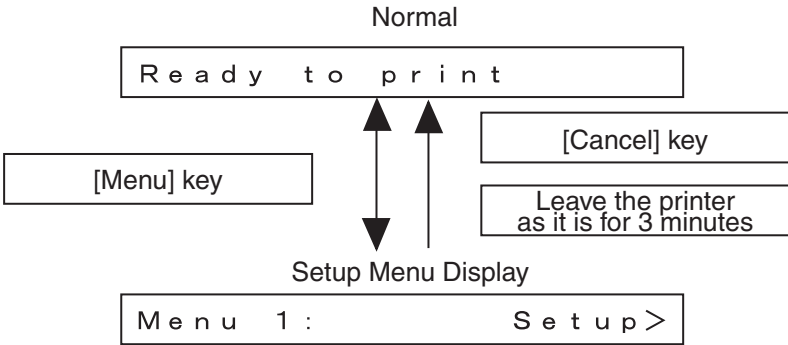

NOTE

- For details on Status message, refer to "[7.2.1 Status messages](#)".

3 Before using

This chapter explains necessary steps before using the printer.

3.1 Power cable connection

This section explains power cable connection.



- **Be sure to use the specified power cable.**
Using power cables other than the specified can cause an electric shock or fire.
- **Use a power cord set which is compatible with the safety standards, power supply voltage, and plug shape used in the country where this printer is used.**
- **Use a power cord set which is equipped with a protective earth, and securely connect it to the outlet.**
- **Do not use a damaged power cable.**
It could lead to an electric shock and fire.

- **Pay attention to the following points when handling power cable.**
- **Do not tamper with the power cable.**
- **Do not put heavy objects on the power cable.**
- **Do not bend, twist or pull the power cable by force.**
- **Do not route the power cable near heating appliances.**

NOTE

- Contact your local MUTOH dealer in case of power cable damage.
- This product is also designed for IT power distribution system with phase-to-phase voltage 230V.

Follow the procedure below to install the power cable.

1. Make sure that the printer is turned OFF.

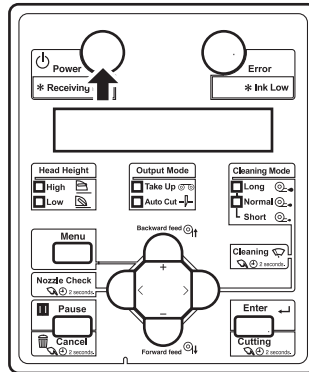

NOTE

- The power is ON when the [Power] key of the operation panel is pressed in. Press the key once again to turn OFF the power.

2. Connect the power cable to the AC inlet on the back of the printer.

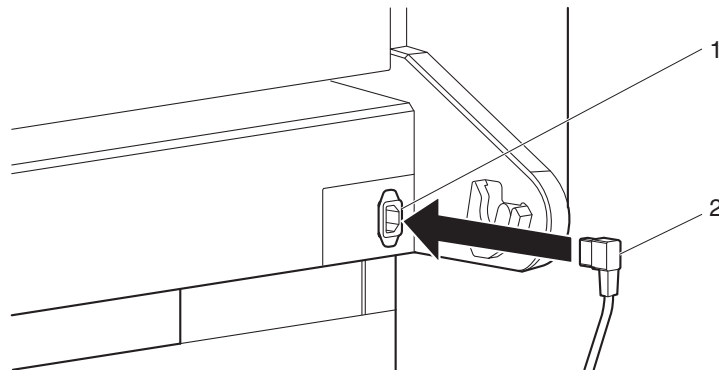

No.	Name
1	AC inlet
2	Power cable

3. Insert the power cable plug firmly in the socket.

**WARNING**

- **Do not pull out or insert the power plug with a wet hand.**
This could lead to an electric shock.
- **Make sure to use only the specified power supply (AC 100 V to 120 V or AC 220 V to 240 V).**
If a power supply other than the specified voltage is used, it could cause an electric shock and fire.
- **Take power for the printer directly from the power socket (AC 100 V to 120 V or AC 220 V to 240 V).**
Do not use multiple plugs on the same socket.
This could generate heat and might cause fire.
- **Be sure to use a dedicated power socket with earth wire for the power supply, and connect it to the earth wire.**
If the earth wire is not connected, an electric shock or fire may occur.
- **Do not connect an earth wire to the following places.**
- **Gas pipes**
There is a possibility of ignition and explosion.
- **Earth wire of telephone cables and lightning rods**
Heavy current might flow whenever lightning strikes.
- **Water pipe and faucet**
The earth might not work if a plastic pipe is connected in the middle of the metal pipe.

- **Pay attention to the following points when handling the power supply plug.**
Any mishandling of the power cable could cause a fire.
- **Make sure that no foreign substances such as dust etc. are stuck to the power plug.**
- **Make sure that the power plug is firmly inserted to the edge of the power socket.**
- **When you do not use the printer for a long period, make sure to pull out the power plug from the power socket for safety.**
- **Make sure to connect an earth wire to the earth connection that meets the following standards.**
- **Earth terminal of power socket**
- **Earth wire with copper plate which is buried at 650 mm or more, deep in the ground.**

NOTE

- Contact the retail outlet of purchase if the earth connection cannot be established, or if the earth connection is not given.
- When the power supply of the printer is ON, do not pull out the power cable from the power socket. Whenever the plug is pulled out from the power socket, allow one minute or more before inserting the plug in the power socket again.

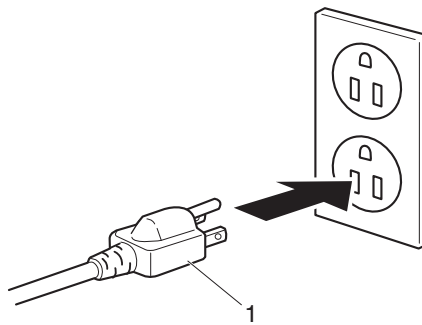

No.	Name
1	Power plug

3.2 Turning the power ON/OFF

This section explains how to turn the printer ON/OFF.

3.2.1 Turning the power ON

Follow the procedure below to turn the power ON.

1. Press the [Power] key on the operation panel to turn ON the printer.
 - Power lamp on the operation panel turns on (blue).

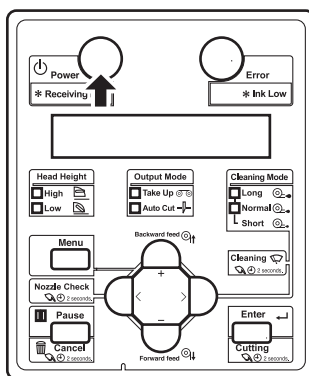

- The printer starts initial operation.
- When the initial operation is complete, the printer enters Normal.

NOTE

- If there is a problem during the initial operation, a message is displayed on the operation panel and the printer may stop operating.
If operation stops, refer to "[7 Troubleshooting](#)" and deal with the problem.

3.2.2 Turning the power OFF

Follow the procedure below to turn the printer OFF.

1. Verify the following regarding the operational condition of the product.
 - Printing or other operations are not in progress.
 - The operation panel display is Normal.
 - The Low lamp on the operation panel lights up in green.

NOTE

- If the High lamp on the operation panel lights up in green, the head height is set to High. Return the head height to Low before turning the power OFF.

 [4.2.5.2 When returning the print head to the original position](#)

2. Press the [Power] key on the operation panel to turn OFF the printer.
 - The Power lamp on the operation panel is turned off.

NOTE

- If the operation panel is in the following status, the power is ON.
 - The [Power] key is pressed in.
 - Power lamp is on (blue).

Press the key once again to turn OFF the power.

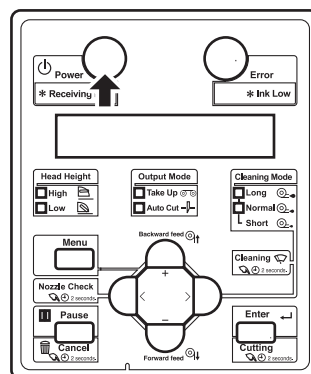

- The printer starts the procedure to turn the power OFF.
- "Power Off" is displayed on the operation panel.

NOTE

- If the head height is set to High, "Set Height to Low" is displayed on the operation panel and the procedure to turn the power OFF stops.
To restart the procedure, return the head height to Low.

☞ [4.2.5.2 When returning the print head to the original position](#)

- All the lamps on the operation panel and the LCD monitor are turned OFF.
- The printer automatically turns the power OFF.

NOTE

- If there is a problem during turning OFF operation, a message is displayed on the operation panel and the printer may stop operating.
If operation stops, refer to "[7 Troubleshooting](#)" and deal with the problem.
- After turning OFF the printer, wait for ten seconds or longer to turn it ON again.

3. Raise the media loading lever when the product is not used for a long time.

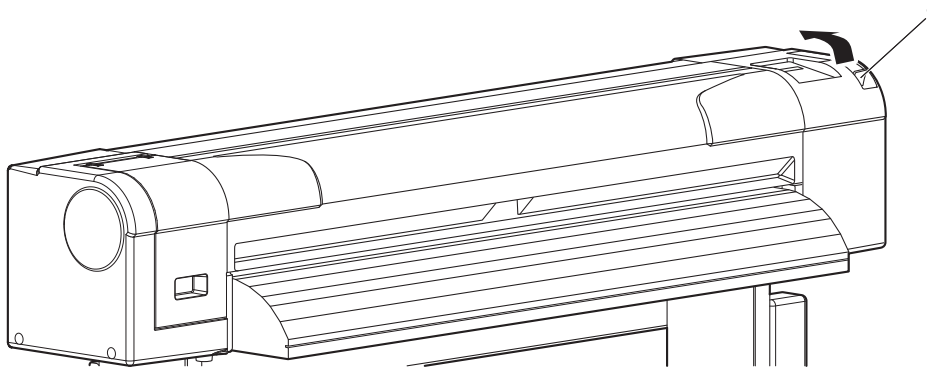

No.	Name
1	Media loading lever

3.3 Installing ink cartridges

This section describes the procedure to install the ink cartridges and high capacity pack adapter.

- **Before operation, make sure to read the Safety Data Sheet (SDS).**
 - **When handling ink cartridges, pay attention so that ink does not get into your eyes or stick to your skin.**
If ink gets into your eyes or sticks to your skin, immediately wash it off with water. Failing to do so might cause irritation or light inflammation of eyes. In case of any abnormality, consult a physician immediately.
 - **Do not disassemble ink cartridges.**
If disassembled, there is a possibility that ink might come into contact with eyes or skin.
 - **Do not perform the following operations during ink filling.**
 - **Do not turn OFF the printer.**
 - **Do not unplug the power cable.**
 - **Do not open the front cover.**
 - **Do not raise the media loading lever.**
- 

NOTE

- Do not share the ink cartridge once installed with another printer. The cartridge will not be usable from that time onward.
- Use genuine ink cartridges or ink packs for charging.
This printer is designed to use genuine ink cartridges or ink packs .
If you use ink cartridges or ink packs which are not produced by the original manufacturer,
- Printing might become blurred and the end of the ink in the cartridge or pack might not be detected correctly.
- Any problems caused by using an ink cartridge or pack other than those recommended above will not be covered by the warranty, and repair expenses will be paid by the customer.
- For types and details of ink cartridges and ink packs, contact your local MUTOH dealer.
- Do not give ink cartridges or ink packs strong shakes.
Doing so may cause ink leakage.
- Do not disassemble ink cartridges or ink packs .
A disassembled ink cartridge cannot be used.
- Make sure to use the dedicated cleaning fluid (Model number: VJ-MSINK3-CL220/VJ-MSINK3-CL1000).
- Before installing the ink cartridges or ink packs, shake it gently.
Doing so will preserve print quality.
- When an ink cartridges or ink packs is moved from a cold place to warm place, keep the ink cartridges or ink packs for three hours or more in the new printing environment before printing.
- Do not insert or remove the ink cartridges or ink packs more than 10 times.
If the ink cartridge has been removed/inserted more than 10 times, it cannot be used even though ink remains.
- The ink cartridges and ink packs for this printer have dedicated IC chip on them.
If removing/inserting the ink cartridges or ink packs and high capacity pack adapters (option) in the following situations, the information within the IC chips may be damaged and the cartridges cannot be used.
- During printing
- For several seconds after inserting the ink cartridge

3.3.1 Installing 220ml ink cartridges

Follow the procedure below to install the 220ml ink cartridge.

1. Turn the printer ON.

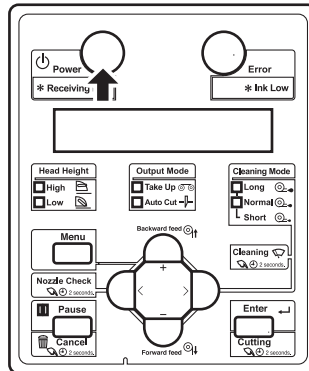

- The printer starts the initializing operation.
- After the initial operation is complete, "Start Ink Charge -> E" is displayed on the operation panel.

2. Press the [Enter] key on the operation panel.

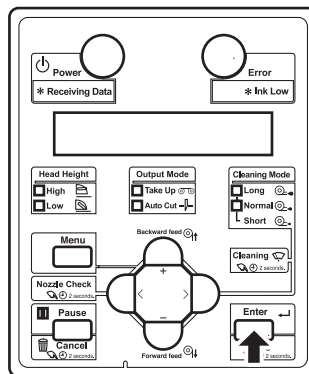

- "Insert Cleaning cart." is displayed on the operation panel.

3. Take out the cleaning cartridge from the bag.

4. Set the cleaning cartridge to the ink cartridge slot.

- Keep ▲ mark of the cleaning cartridge facing up and insert towards the printer side.
- Insert the cleaning cartridge all the way to the end of the slot.

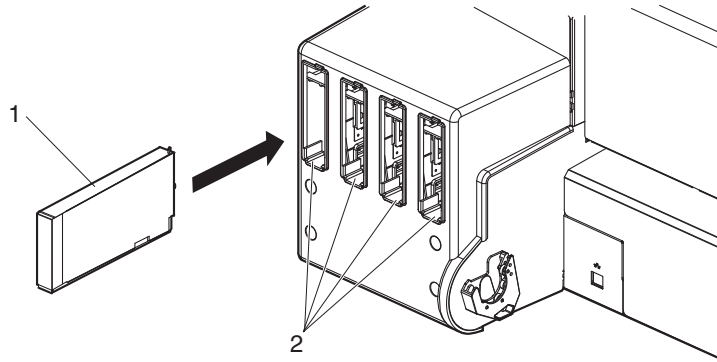

No.	Name
1	Cleaning cartridge
2	Ink cartridge slots

- When all cleaning cartridges are installed, "Busy-Washing" is displayed on the operation panel, and the printer starts charging the cleaning fluid.
- When the cleaning fluid has been charged, "Remove Cartridges" is displayed on the operation panel.

5. Remove all cleaning cartridges.

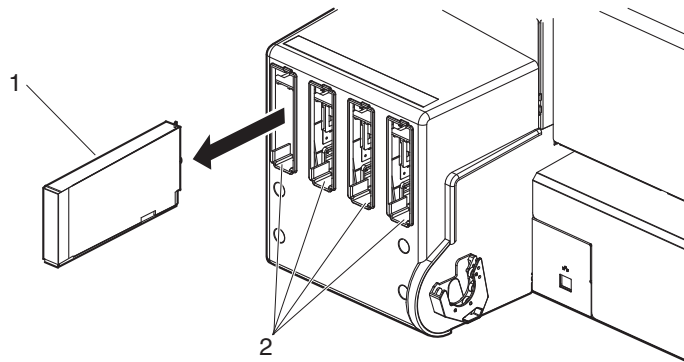

No.	Name
1	Cleaning cartridge
2	Ink cartridge slots

- "Busy-Washing" is displayed on the operation panel and the printer starts head cleaning.
- When head cleaning is complete, "Wash retry? No" is displayed on the operation panel.

NOTE

- When performing head cleaning again before ink charge, press the [+] or [-] key on the operation panel to select "Yes", and press the [Enter] key to perform head cleaning.

6. Press the [Enter] key on the operation panel.

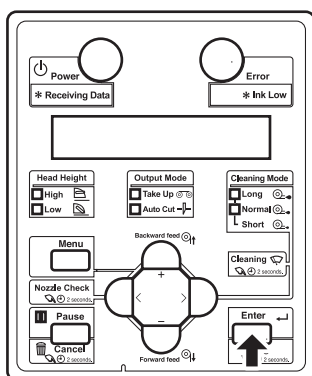

- "Insert InkCartridges" is displayed on the operation panel.
7. Take out the ink cartridge from the bag and shake it gently two to three times and insert it into the printer.
- Make sure that the ink cartridges are inserted into the correct slots. Match the mark in front of the slot and the color of the ink before inserting the ink cartridge.
 - Keep ▲ mark of the ink cartridge facing up and insert towards the printer side.
 - Insert the ink cartridge all the way to the end of the slot.

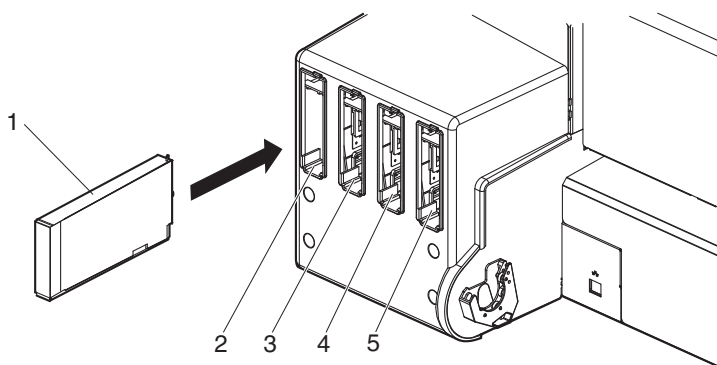

No.	Name
1	Ink cartridge
2	Ink cartridge slot K
3	Ink cartridge slot C
4	Ink cartridge slot M
5	Ink cartridge slot Y

- "Ink Refill **%" is displayed on the operation panel and initial ink charge starts.

- Initial ink charge takes about four minutes.
Ink filling operation and pause operation are repeated during the initial ink charge.
- When "100%" is displayed, the initial ink charge is complete.
- **Do not perform the following operations during ink filling. If filling is interrupted, ink will be lost when filling is resumed.**
- **Do not turn OFF the printer.**
- **Do not unplug the power cable.**
- **Do not open the front cover.**
- **Do not open the maintenance cover.**
- **Do not raise the media loading lever.**

- After the initial ink charge is complete, "Media End" is displayed on the operation panel.

NOTE

- If the printer performs the nozzle check printing immediately after initial ink charge is complete, the following results may occur.
- Printed lines become blurred.
- The data is partially not printed.

In such cases, follow "[6.2.3 Head cleaning](#)" and refill a small amount of ink. Then, check the printing result.

If there is no improvement in the print result even after refill a small amount of ink, leave the printer unused for an hour or more. Then, refill a small amount of ink again and check the print result.

If there is still no improvement, contact your local MUTOH dealer.

3.3.2 Installing high capacity pack adapters (option)

Use the optional high capacity pack adapters to use the 1000ml ink packs on this printer.

Follow the procedure below to install the high capacity pack adapters.

1. Turn the printer ON.

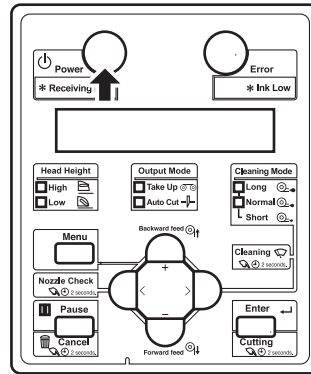

- The printer starts the initializing operation.
 - After the initial operation is complete, "Start Ink Charge -> E" is displayed on the operation panel.
2. Press the [Enter] key on the operation panel.

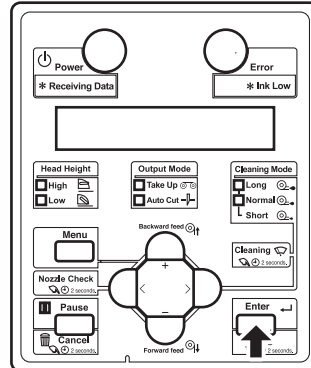

- "Insert Cleaning cart." is displayed on the operation panel.
3. Take out the cleaning fluid packs (4 pieces) from the bag.
 4. Install the cleaning fluid pack and smart chip card to the high capacity pack adapters.

NOTE

- To install or remove the cleaning fluid pack and smart chip card to/from the high capacity pack adapter, refer to the operation manual included with high capacity pack adapter.

5. Insert the high capacity pack adapters into the ink cartridge slot.

NOTE

- Do not insert the high capacity pack adapter into the ink cartridge slot without a cleaning fluid pack attached.
The information of the remaining amount will be overwritten and the cleaning fluid pack will not be usable.

- Insert the high capacity pack adapter all the way to the end of the slot.

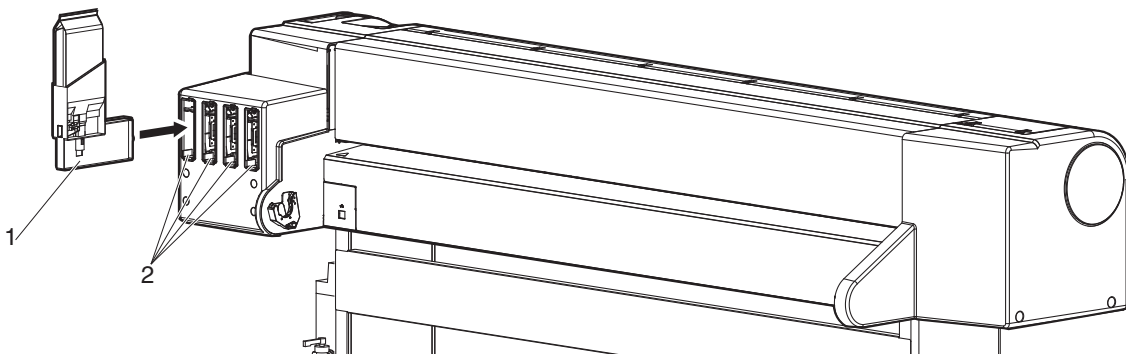

No.	Name
1	High capacity pack adapter
2	Ink cartridge slots

- When all high capacity pack adapters are installed, "Busy-Washing" is displayed on the operation panel, and the printer starts charging the cleaning fluid.
- When the cleaning fluid has been charged, "Remove Cartridges" is displayed on the operation panel.

6. Remove all the high capacity pack adapters.

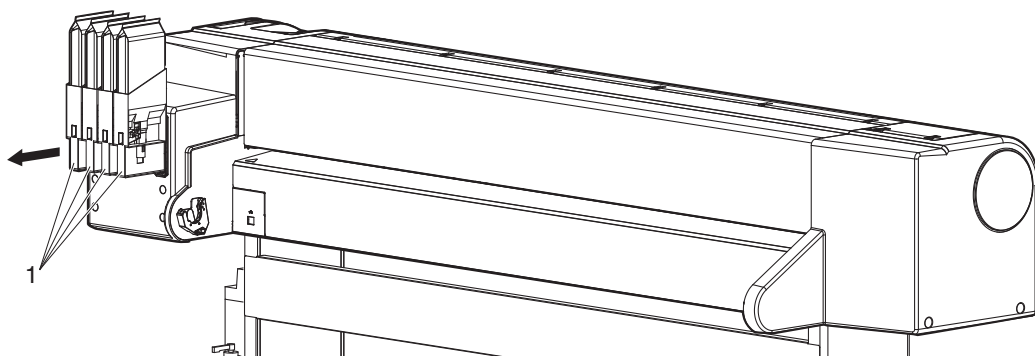

No.	Name
1	High capacity pack adapter

- "Busy-Washing" is displayed on the operation panel and the printer starts head cleaning.
- When head cleaning is complete, "Wash retry? No" is displayed on the operation panel.

NOTE

Do not remove only cleaning fluid pack while high capacity pack adapter is installed on the printer. The information of the remaining smart chip card will be rewritten and the cleaning fluid pack will not be usable.

7. Press the [Enter] key on the operation panel.

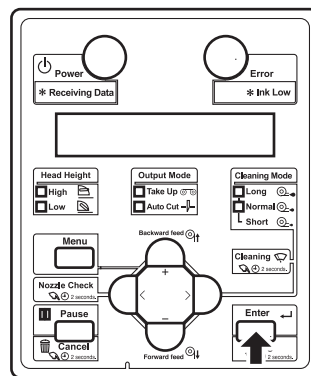

- "Insert InkCartridges" is displayed on the operation panel.
8. Remove the cleaning fluid pack and smart chip card from the high capacity pack adapter.

NOTE

- When there is remaining cleaning fluid pack and smart chip card, clarify the corresponding pack and card, and store it as a set.

9. Install the ink pack and smart chip card to high capacity pack adapter.

10. Shake the high capacity pack adapter gently two to three times and insert it to the slot.

NOTE

• Do not insert the high capacity pack adapter into the ink cartridge slot without a cleaning fluid pack attached.

The information of the remaining amount will be overwritten and the cleaning fluid pack will not be usable.

- Insert the high capacity pack adapter all the way to the end of the slot.

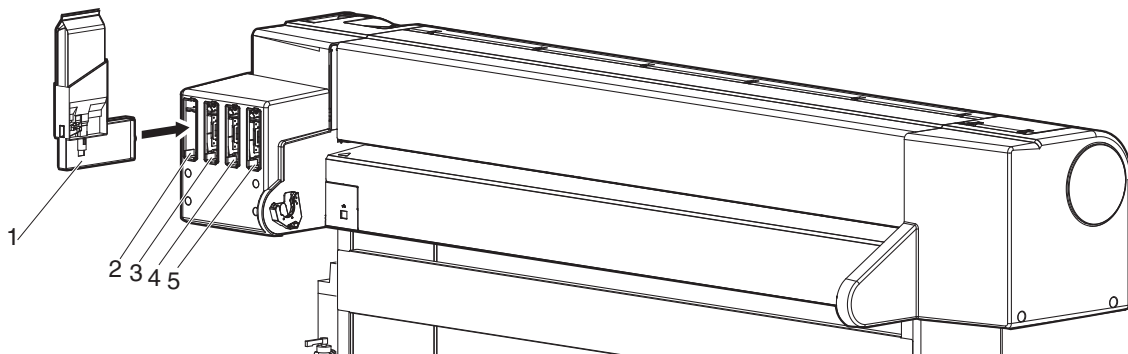

No.	Name
1	High capacity pack adapter
2	Ink cartridge slot K
3	Ink cartridge slot C
4	Ink cartridge slot M
5	Ink cartridge slot Y

- When a high capacity pack adapter is installed, "Ink Refill **%" is displayed on the operation panel and ink replenishment starts.
- Initial filling takes about eight minutes.
Ink filling operation and pause operation are repeated during the ink replenishment.
- When "100%" is displayed, the ink replenishment is complete.

- Do not perform the following operations during ink filling. If filling is interrupted, ink will be lost when filling is resumed.
- Do not turn OFF the power of the printer.
- Do not unplug the power cable of the printer.
- Do not open the front cover.
- Do not open the maintenance cover.
- Do not raise the media loading lever.

- After the ink replenishment is complete, "Media End" is displayed on the operation panel.

NOTE

- If the printer perform the nozzle check printing immediately after initial ink replenishment is complete, the following results may occur.
- Printed lines become blurred.
- The data is partially not printed.

In such cases, follow "**6.2.3 Head cleaning**" and refill a small amount of ink. Then, check the printing result.

If there is no improvement in the print result even after refill a small amount of ink, leave the printer unused for an hour or more. Then, refill a small amount of ink again and check the print result.

If there is still no improvement, contact your local MUTOH dealer.

3.3.3 When using the high capacity pack adapter for the printer whose ink is charged for the first time

The air inside the high capacity pack adapter goes into the printer ink tube and may cause nozzle clogging. Make sure to perform initial ink charge from the Cleaning menu in the following case.

- When using the high capacity pack adapter for the printer whose ink is charged for the first time
- When replacing the high capacity pack adapter's adapter itself with a new one

5.3 Cleaning menu

3.4 Loading media

This section explains how to load and set media, and settings for each media type.

NOTE

- Refer to the following for details about handling media.
🔗 [4.2 Media](#)
 - For details of the recommended media, contact your local MUTOH dealer.
-

3.4.1 Loading roll media

This section describes the procedure to load the roll media.

To load the roll media, use the scroller included with the printer.

NOTE

- The following roll media can be loaded on the scroller included with the printer.
 - Media tube with a diameter of three inches: Less than 150mm in outer diameter, less than 19kg in weight
 - Media tube with a diameter of two inches: Less than 150mm in outer diameter, less than 19kg in weight
-

Follow the procedure below to load the roll media.

- **When loading the roll media, place it on a flat surface such as a desk.
If the roll media is loaded with the scroller up, the scroller may be damaged.**

1. When using the roll media with the media tube width of two inches, remove the attachments for three-inch media from the movable media stopper and fixed media stopper.

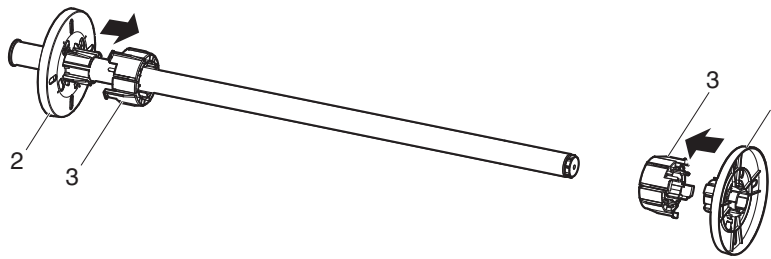

No.	Name
1	Movable media stopper
2	Fixed media stopper
3	Attachments for three-inch media

2. To set the roll media on the scroller, make sure that the paper is rolled counter-clockwise when seen from the fixed media stopper.
3. Insert the roll media all the way till its core touches the right edge of the fixed media stopper.

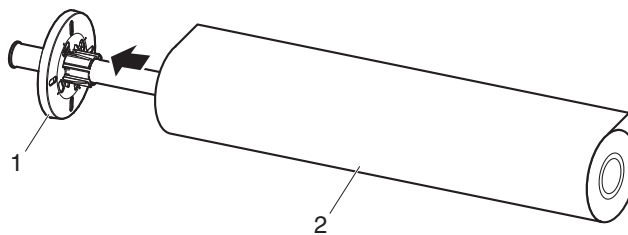

No.	Name
1	Fixed media stopper
2	Roll media

4. Attach the movable media stopper firmly to the core of the roll media.

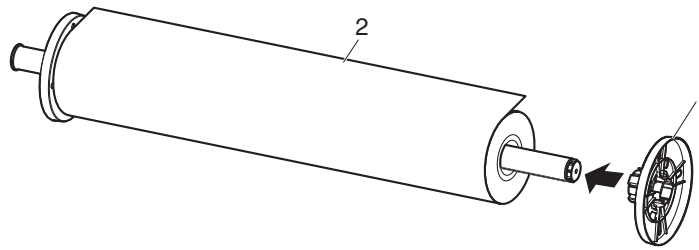

No.	Name
1	Movable media stopper
2	Roll media

5. Set the scroller on the holder with the fixed media stopper on the ink cartridge slot side.

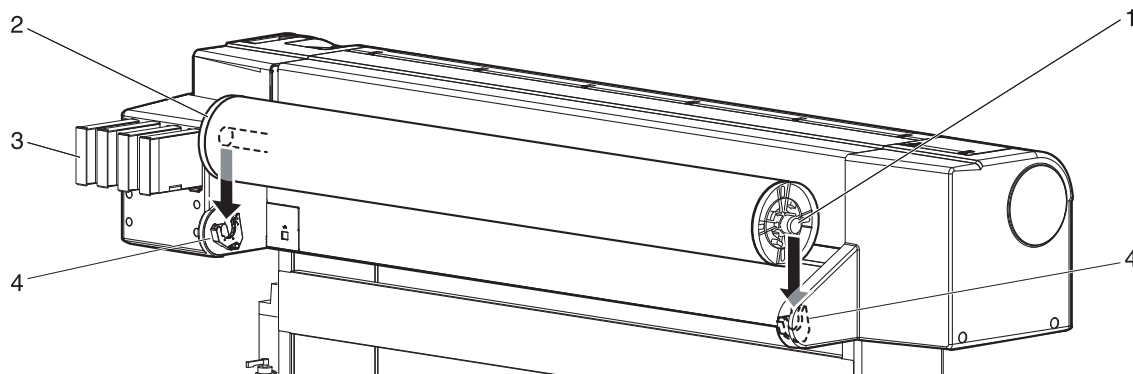

No.	Name
1	Scroller
2	Fixed media stopper
3	Ink cartridge slots
4	Scroller holder

3.4.2 Setting Roll Media

This section explains how to set the roll media.

Follow the procedure below to set the roll media.

1. Turn the printer ON.

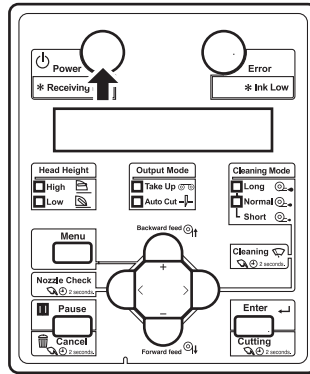

- **Do not operate the media loading lever during the initial operation or printing. The print head portion may touch the pressurizing roller portion, and cause a malfunction.**



- The printer starts the initializing operation.
 - "Media End" is displayed on the operation panel.
2. Raise the media loading lever.

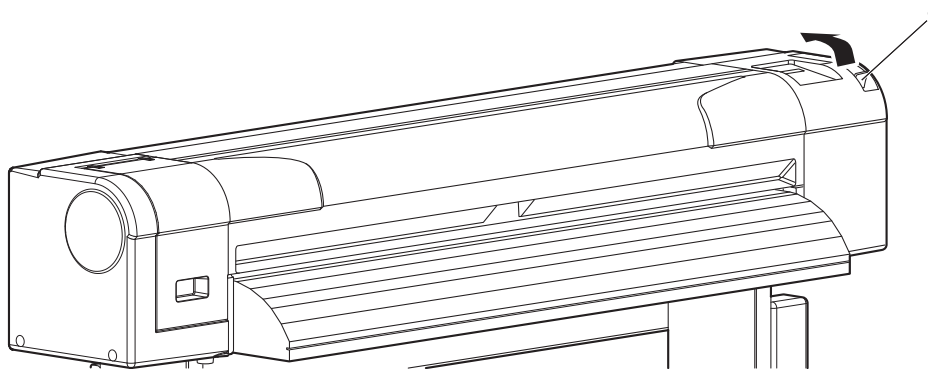

No.	Name
1	Media loading lever

- "Lever Up" is displayed on the operation panel.

3. Set the roll media to the media feed slot.

NOTE

- If the end of the roll media is not wound tightly, wind it tightly again, and then load it.

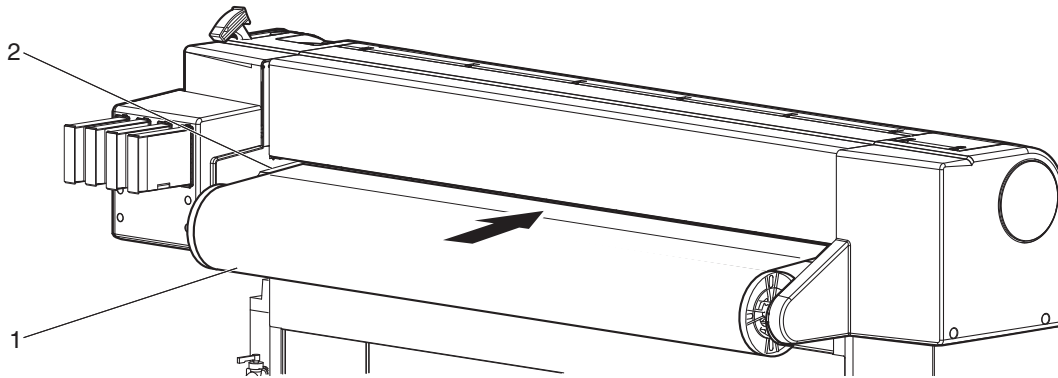

No.	Name
1	Roll media
2	Media feed slot

4. Open the front cover to pull out the roll media.

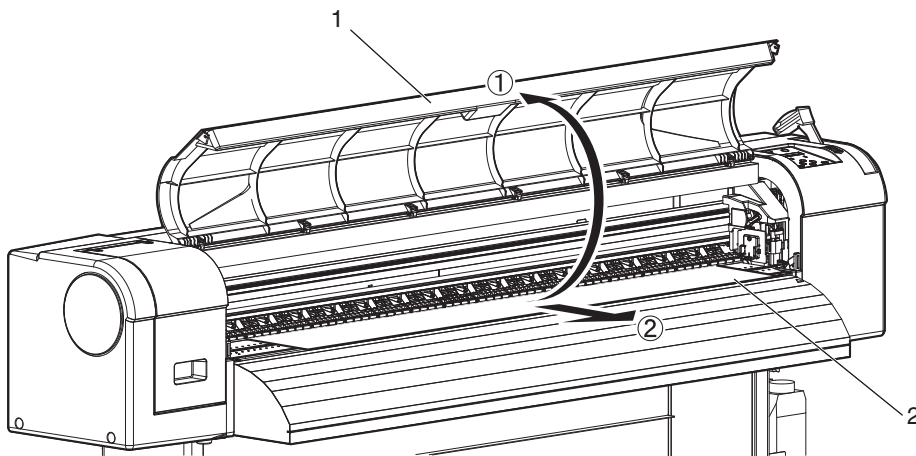

No.	Name
1	Front cover
2	Roll media

5. While holding the edge of the media, rewind the roll media a little by turning the scroller by hand and eliminate any slack or slant.

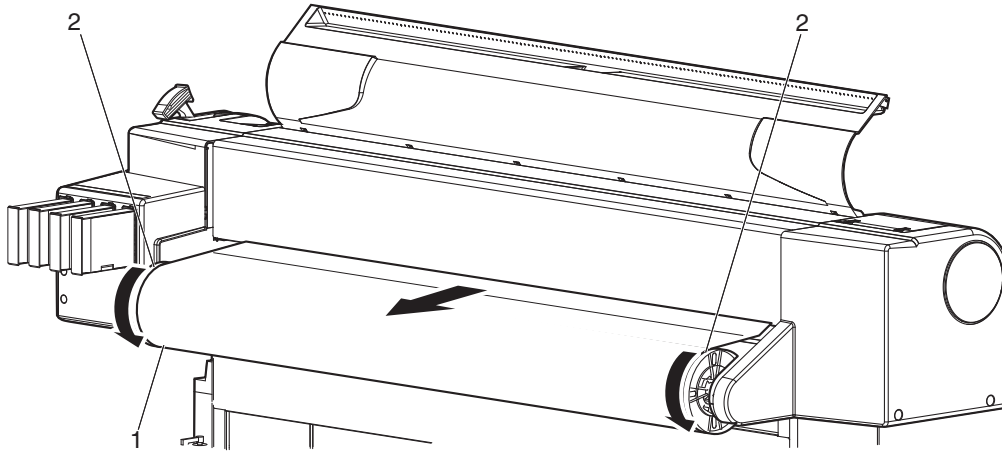

No.	Name
1	Roll media
2	Scroller

6. Lower the media loading lever.

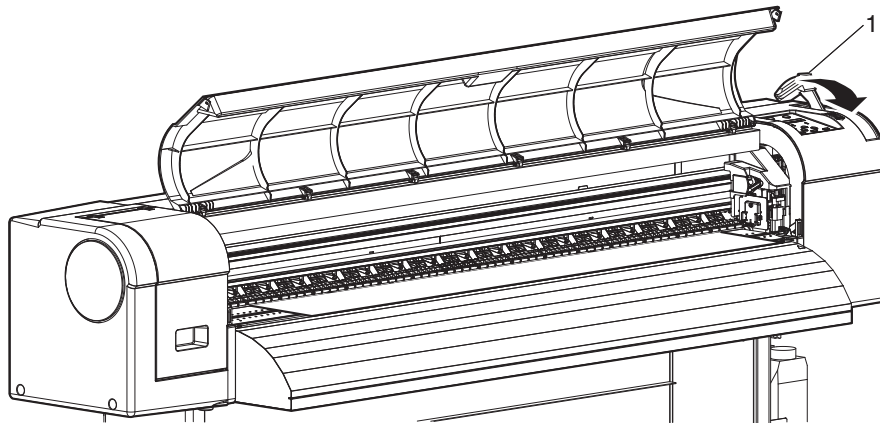

No.	Name
1	Media loading lever

NOTE

- When loading the new roll media, cut the front edge of the media if it is not straight.

[4.4.3 Cutting media](#)

7. Close the front cover.

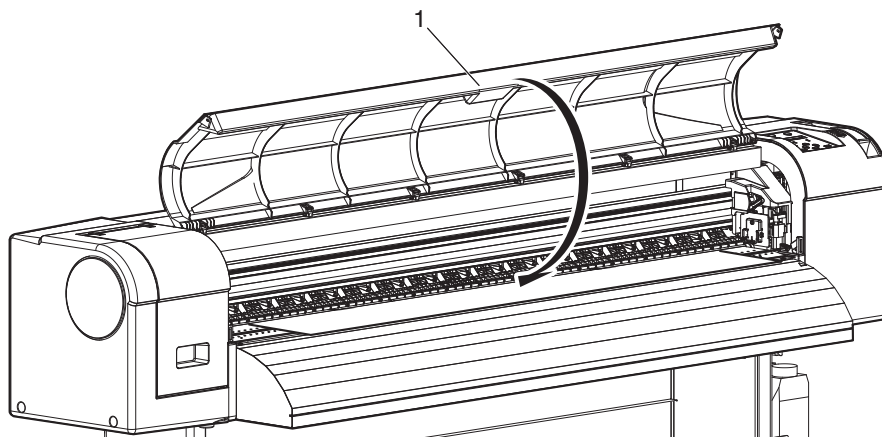

No.	Name
1	Front cover

- The User type setup menu is displayed on the operation panel.

TIP

To change the media type, follow "[3.4.3 Setting the User Type Setting](#)" and set the media type.

3.4.3 Setting the User Type Setting

This section explains how to set the user type setting.

Follow the procedure below to set the user type setting.

1. Turn ON the printer and load media.

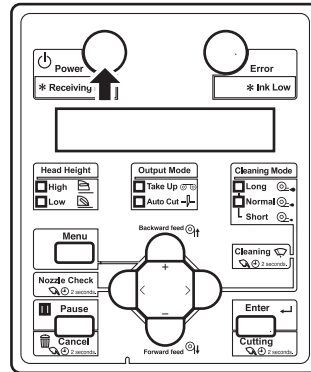

- After loading the media, the printer enters the user type setting menu.

TIP

Refer to the following for setting media.

[3.4.2 Setting Roll Media](#)

2. Press the [+] key or [-] key to select the user type setting.

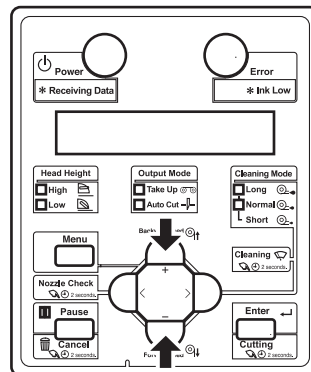

3. Press the [Enter] key on the operation panel.

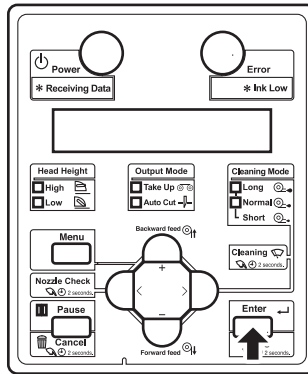

- The user type setting is set.
- "Media initial" is displayed on the operation panel and media initialization starts.

NOTE

- If the following operations are performed in the user type setting menu, the printer starts media initial operation without specifying a user-defined setting.
- Pressing the [Cancel] key on the operation panel.
- No keys on the operation panel are pressed for 30 seconds.

- After media initial operation is complete, "Ready to Print" is displayed on the operation panel and the display shifts to Normal.

4. When using the roll media, turn the scroller by hand to rewind the roll media and eliminate any slack.

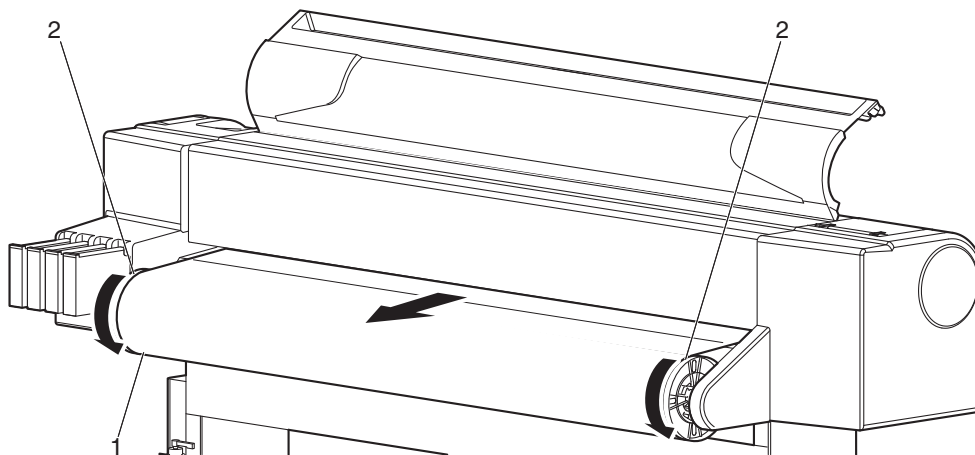

No.	Name
1	Roll media
2	Scroller

- Media set is complete.

3.5 Test print

Follow the procedure below to perform Test printing to confirm that the printer works correctly.

1. Turn ON the printer and load the media.
 🔗 [3.4.2 Setting Roll Media](#)
2. Confirm that the printer functions normally.
3. Display the Test Print menu on the operation panel.
 - a. Press the [Menu] key on the operation panel.

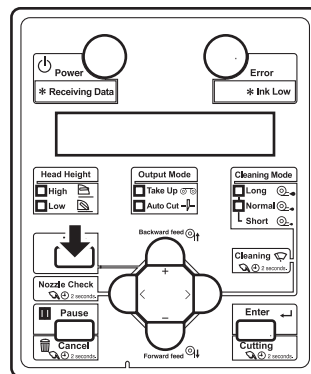

- "Menu 1: Setup>" is displayed on the operation panel.
 - The operation panel shifts to the Setup menu display.
- b. Press the [+] key or [-] key to select "Menu2: Test Print>".

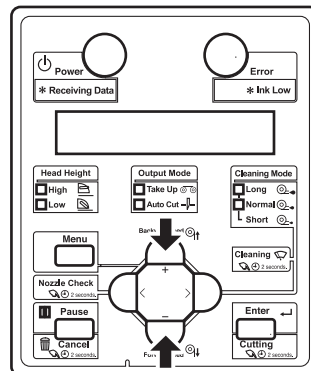

- c. Press the [>] key on the operation panel.

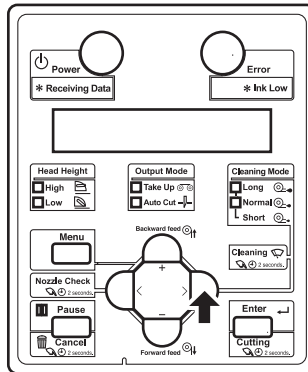

- "Test1: Nozzle Check" is displayed on the operation panel.
- The display shifts to the Test Print menu.

5.2 Test Print Menu

4. Press the [+] key or [-] key on the operation panel to select an item for printing from the following items.

- Nozzle Check
- Mode Print
- Setup List
- Palette
- Color Verify

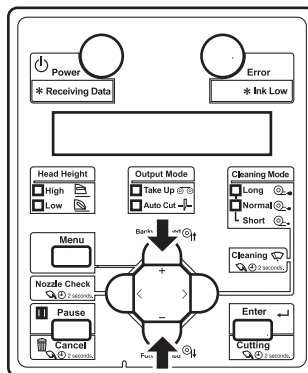

TIP

For the Color Verify operating procedure, refer to "3.5.5 Color Verify".

- Press the [Enter] key on the operation panel.

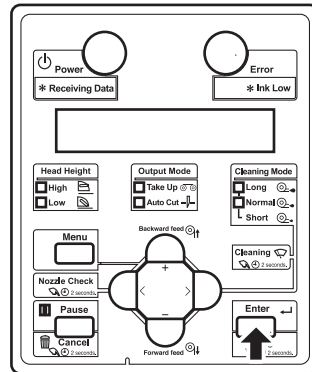

- Start performing Test Print for the selected item.

TIP

Refer to the following for details on each of the print list items.

➤ [3.5.1 Nozzle check](#) to [3.5.5 Color Verify](#)

- Repeat step 4 to step 5 when performing test print for other items.
- Press the [Cancel] key on the operation panel to exit from test print.

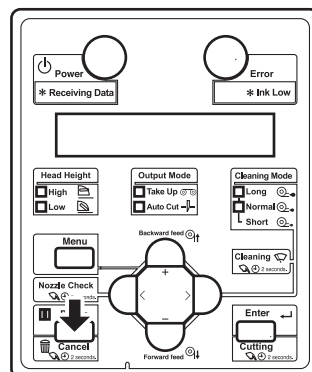

- The operation panel returns to Normal.
- The procedure for test printing is complete.

3.5.1 Nozzle check

It is used to check whether there are any clogged heads, or missing or blurred prints.

NOTE

- If the nozzle check result indicates that the checked points are blurred or missing, clean the head.

➤ [6.2.3 Head cleaning](#)

Perform the nozzle check once again at the end of the work.

TIP

Refer to the following for printing procedure.

➤ [3.5 Test print](#)

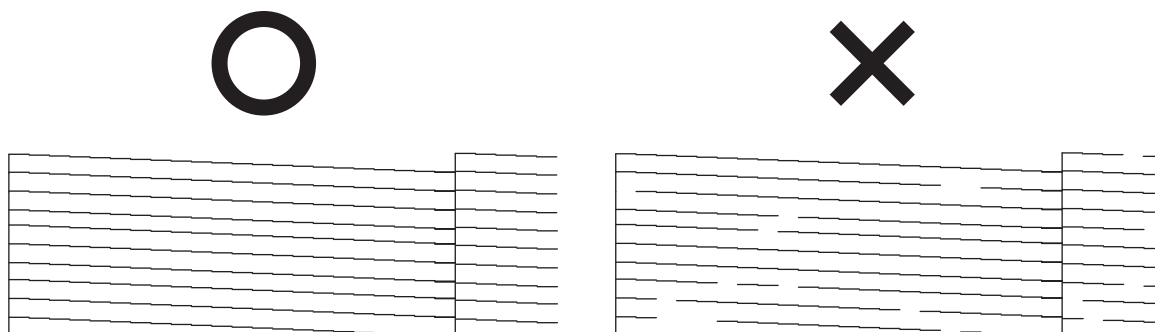

3.5.2 Mode print

Used to confirm the following printing conditions.

- Print Mode
- Effect
- Preset Pre heater temperature
- Preset platen-heater temperature
- Preset dryer temperature
- Adjustment value

TIP

Refer to the following for printing procedure.

 [3.5 Test print](#)

2011/01/01 0:00 G2(720x720 8Pass Bi)-Fine&Fuzz/Pre:30°C/Platen:30°C/After:30°C/PF Adjust:0

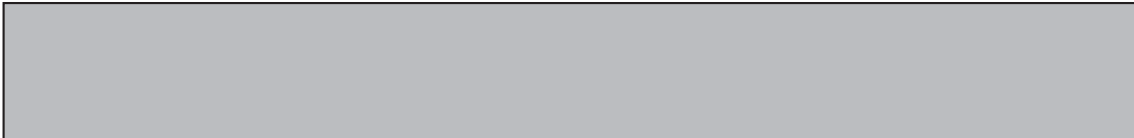

3.5.3 Setup print

Used to check the current setup of the printer.

NOTE

- Keep the printed setup print at hand.

TIP

Refer to the following for printing procedure.

 **3.5 Test print**

Setup List		2010/08/01 0:00	
<Information>			
SerialNo.	= XXXX00001	Firmware M	= V 1.00
Model	= VJ-1324	Firmware C	= V 1.10
Memory Size	= 128MB	Error!	0: None [] 2: None [] 4: None [] 1: None [] 3: None [] 5: None []
<Menu Setup>			
[Number][Select]Menu = Setup		Head Height : Low Cleaning Mode: Normal	
[1][*]User Type = Type 1	[15][*]Auto Cleaning = 360min	WaitingTime = 360min	
[2]Effect = A-S.Fine&Wave	PrintingTime = Off	Before Print = Off	
[3]Adjust Print	[16][*]Ink Status	Smart/Chip KCMY ---/---/--- Smart/C 0% Max 3520ml	
[4]PF Adjust	[17][*]RollKind = Off	[18][*]Longstore	
[1]Initial Adj. Print = 250.0/250mm	[19][*]OR Maintenance	[20][*]Initialization	
[3]Confirm Adj. Print	[21][*]Life Times	Head : E*****F Pump : E*****F OR Motor : E*****F PF Motor : E*****F	
[4]Micro Adj. Print = 0.00%	[22][*]IP Address = 192.168.001.253	[23][*]Subnet Mask = 255.255.255.000	
[5]Preheater = 30 C	[24][*]Gateway = 192.168.001.254	SleepModeTimer = 6h	
[6]PlatenHeater = 30 C	Language = English	Temperature = Celsius[°C]	
[7]Dryer = 30 C	Length = mm		
[8]Vacuum Fan = 30 C			
[2][*]Spitting = On(Pass Count = 1cnt)			
[3][*]Side Margin = 5mm			
[4][*]Media Initial = Width			
[5][*]Media Width = 1000mm			
[6][*]Output Mode = Off			
[7][*]Method of Cut = SingleCut-2steps(InkDryerTimer= 0sec)			
[8][*]Origin			
[9][*]Prevent Stick = Off			
[10][*]Standby Heating = 60min			
[11][*]Head Travel = Data			
[12][*]Multi Strike = 1cnt			
[13][*]Strike Wait = 0.0sec			
[14][*]Media Slant = On			

<User Type List>

User Type	Type 1	Type 2	Type 3	Type 4	Type 5	Type 6	Type 7	Type 8	Type 9	Type 10
Print Mode	Graphics 2	Graphics 2	Graphics 2	Graphics 2	Graphics 2	Graphics 2	Graphics 2	Graphics 2	Graphics 2	Graphics 2
Effect	A-S.Fine&Wave	Fine&Fuzz	Fine&Fuzz	Fine&Fuzz	Fine&Fuzz	Fine&Fuzz	Fine&Fuzz	Fine&Fuzz	Fine&Fuzz	Fine&Fuzz
PF)Initial Adjust	250.0/250mm	250.0/250mm	250.0/250mm	250.0/250mm	250.0/250mm	250.0/250mm	250.0/250mm	250.0/250mm	250.0/250mm	250.0/250mm
PF)Micro Adjust	0.00%	0.00%	0.00%	0.00%	0.00%	0.00%	0.00%	0.00%	0.00%	0.00%
Preheater	30 C	30 C	30 C	30 C	30 C	30 C	30 C	30 C	30 C	30 C
PlatenHeater	30 C	30 C	30 C	30 C	30 C	30 C	30 C	30 C	30 C	30 C
Dryer	30 C	30 C	30 C	30 C	30 C	30 C	30 C	30 C	30 C	30 C
Vacuum Fan	High	High	High	High	High	High	High	High	High	High
User Type	Type11	Type12	Type13	Type14	Type15	Type16	Type17	Type18	Type19	Type20
Print Mode	Graphics 2	Graphics 2	Graphics 2	Graphics 2	Graphics 2	Graphics 2	Graphics 2	Graphics 2	Graphics 2	Graphics 2
Effect	Fine&Fuzz	Fine&Fuzz	Fine&Fuzz	Fine&Fuzz	Fine&Fuzz	Fine&Fuzz	Fine&Fuzz	Fine&Fuzz	Fine&Fuzz	Fine&Fuzz
PF)Initial Adjust	250.0/250mm	250.0/250mm	250.0/250mm	250.0/250mm	250.0/250mm	250.0/250mm	250.0/250mm	250.0/250mm	250.0/250mm	250.0/250mm
PF)Micro Adjust	0.00%	0.00%	0.00%	0.00%	0.00%	0.00%	0.00%	0.00%	0.00%	0.00%
Preheater	30 C	30 C	30 C	30 C	30 C	30 C	30 C	30 C	30 C	30 C
PlatenHeater	30 C	30 C	30 C	30 C	30 C	30 C	30 C	30 C	30 C	30 C
Dryer	30 C	30 C	30 C	30 C	30 C	30 C	30 C	30 C	30 C	30 C
Vacuum Fan	High	High	High	High	High	High	High	High	High	High
User Type	Type21	Type22	Type23	Type24	Type25	Type26	Type27	Type28	Type29	Type30
Print Mode	Graphics 2	Graphics 2	Graphics 2	Graphics 2	Graphics 2	Graphics 2	Graphics 2	Graphics 2	Graphics 2	Graphics 2
Effect	Fine&Fuzz	Fine&Fuzz	Fine&Fuzz	Fine&Fuzz	Fine&Fuzz	Fine&Fuzz	Fine&Fuzz	Fine&Fuzz	Fine&Fuzz	Fine&Fuzz
PF)Initial Adjust	250.0/250mm	250.0/250mm	250.0/250mm	250.0/250mm	250.0/250mm	250.0/250mm	250.0/250mm	250.0/250mm	250.0/250mm	250.0/250mm
PF)Micro Adjust	0.00%	0.00%	0.00%	0.00%	0.00%	0.00%	0.00%	0.00%	0.00%	0.00%
Preheater	30 C	30 C	30 C	30 C	30 C	30 C	30 C	30 C	30 C	30 C
PlatenHeater	30 C	30 C	30 C	30 C	30 C	30 C	30 C	30 C	30 C	30 C
Dryer	30 C	30 C	30 C	30 C	30 C	30 C	30 C	30 C	30 C	30 C
Vacuum Fan	High	High	High	High	High	High	High	High	High	High

3.5.4 Palette print

Palette print is executed for the color demonstration.

TIP

Refer to the following for printing procedure.

 [3.5 Test print](#)

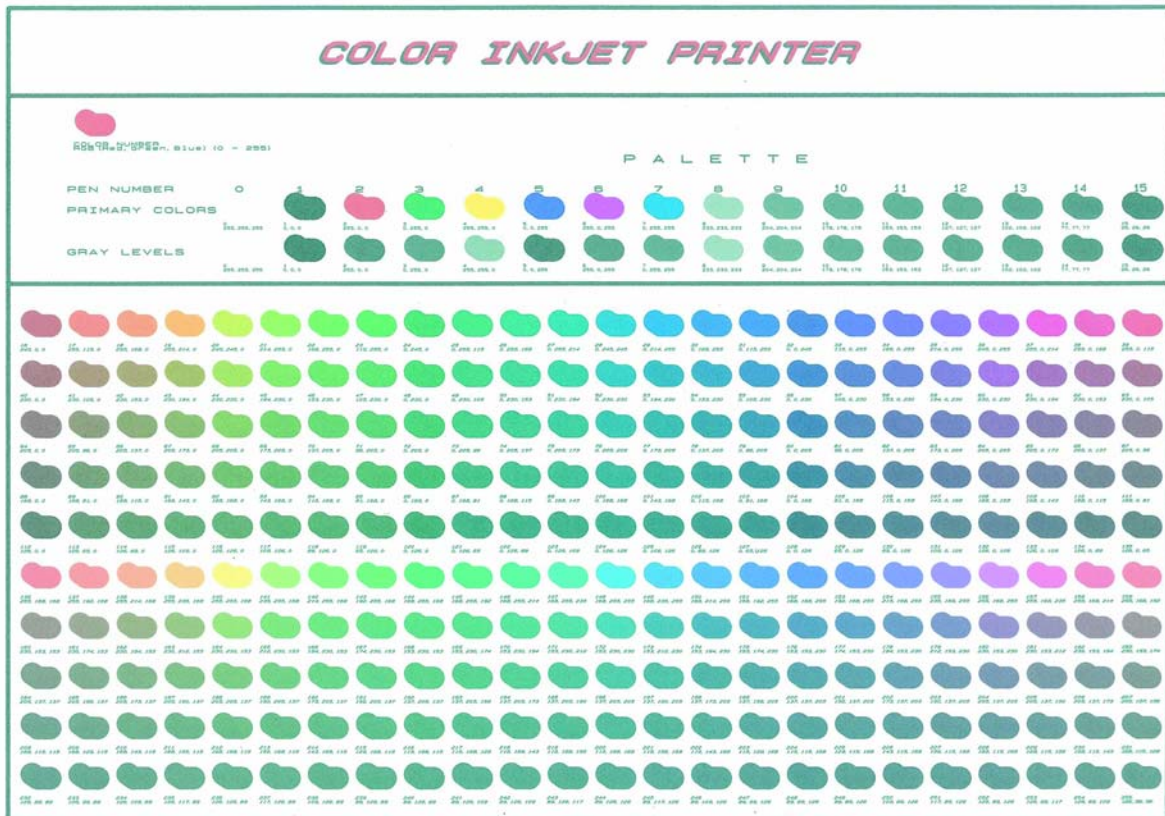

3.5.5 Color Verify

The color to be printed by printer varies depending on the aging variation of printer and ink, and the lot difference between media, even under the same printing condition. This "Color Verify" is a function to check the difference between the colors printed before and now.

In this function, 14 color patches are printed, and the colors are measure by the optional spectrophotometer (SPECTROVUE VM-10). If the Color Verify was performed before and the measured value was saved as the baseline, the color difference from the baseline will be printed as a result.

Follow the 2 steps below to check the color reproducibility using the Color Verify.

1. Save the baseline

Perform the Color Verify under the condition* of comparison criterion, and save the measured value (only one baseline can be saved).

* e.g.: To use a new media, after an initial ink charge, before starting the continuous print job, etc.

2. Check the current color reproducibility (Comparison with the baseline)

When a media or ink is replaced, or when the job that has been printed in the past, is printed again, compare the color with the baseline to check if there is no significant change in the color reproducibility. When the Color Verify is executed, the color difference (dE) is printed on the top of each color patch. If the color difference (dE) is quite large, it means that the color reproducibility has varied from when the baseline was saved. In general, if the dE is more than 3.2, the color difference in the print result will be visible.

TIP

In this function, the color difference (dE) is calculated based on CIE 94*.

* CIE94 is proposed by CIE (International Commission of Illumination) in 1994.

NOTE

- The optional SPECTROVUE VM-10 is required to perform this function. For more information, contact your local MUTOH dealer.
- Before performing this function, make sure to print the nozzle check pattern to check if there is no missing nozzle.
- In order to perform the Color Verify correctly, make sure to specify the following settings same as the setting when the baseline was saved. If these settings are different, the color difference may become large.
 - Each Heater Temperature Setting, Effect Setting, CR Print Width Setting, Overwrite Setting
 - Use this function with the head height adjustment lever is in the "Low" position.
- Since the room environment (temperature, humidity) may affect the print color, create the environment in accordance with the environment condition described in this manual "[8.1.1 Printer specifications](#)" "Environment Condition". In addition, make sure to place the media and ink in the printing environment for 2 hours before use.
- In this function, the baseline cannot be saved for each media. To perform the Color Verify with a different media, the new baseline should be saved. (If the media is replace to the one previously used, the baseline should be saved again.)
- "Color Verify" is a function to check the color variation in print color caused by various causes. This function is not to guarantee the color reproducibility of the printer.

Follow the procedure below to perform the Color Verify

1. Turn ON the printer and load the roll media.
 - ☞ [3.4.2 Setting Roll Media](#)
2. Set the user type setting.
 - ☞ [3.4.3 Setting the User Type Setting](#)
3. Check the temperature setting of each heater.
 - Preset Pre heater temperature
 - ☞ [5.1.1.1.5 Pre-heater menu](#)
 - Preset platen-heater temperature
 - ☞ [5.1.1.1.6 Platen heater menu](#)
 - Preset dryer temperature
 - ☞ [5.1.1.1.7 Dryer menu](#)
4. Display the Test Print menu on the operation panel.
 - a. Press the [Menu] key on the operation panel.

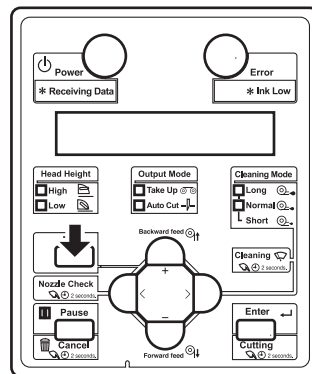

- "Menu1: Setup>" is displayed on the operation panel.
 - The operation panel shifts to the Setup menu display.
- b. Press the [+] key or [-] key to select "Menu2: Test Print>".

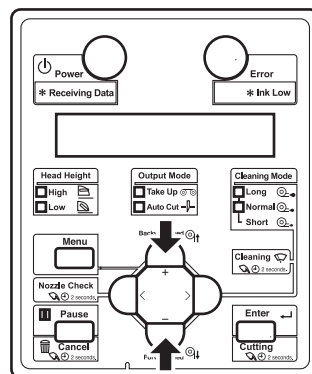

- c. Press the [>] key on the operation panel.

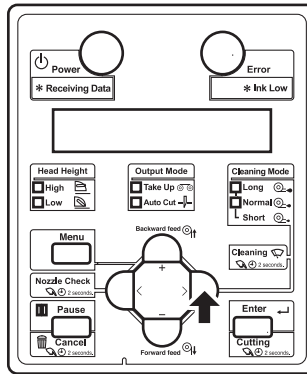

- "Test1: Nozzle Check" is displayed on the operation panel.
- The display shifts to the Test Print menu.

5.2 Test Print Menu

5. Press the [+] key or [-] key on the operation panel to select " Test5: Color Verify".

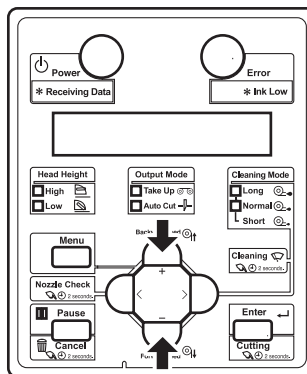

6. Press the [Enter] key on the operation panel.

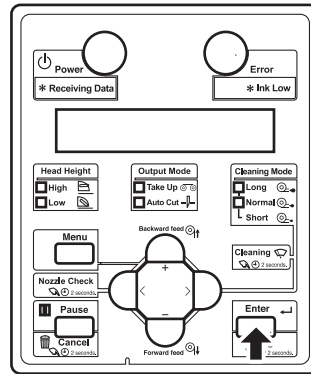

- The printing of following items starts.
 - Color Patches
 - User Type
 - Preset Heater Temperature
 - Preset Pre Heater Temperature
 - Preset Platen Heater Temperature
 - Preset Dryer Temperature
 - Head Temperature Information

NOTE

- Do not open the covers or move media loading lever during printing.

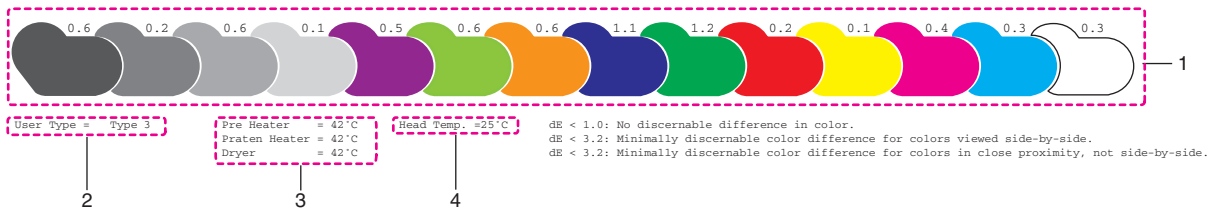

No.	Name
1	Color Patches
2	User Type
3	Preset Heater Temperature
4	Head Temperature Information

- After printing is complete, "Attaching instrument [ENTER]" is displayed on the operation panel.

7. Press the [Enter] key.

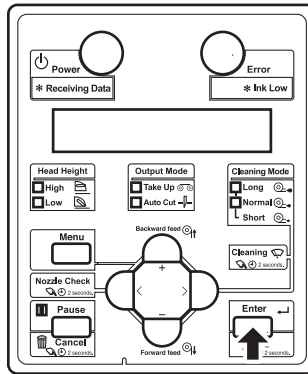

- "Open mainte. cover." is displayed on the operation panel.

8. Open the maintenance cover.

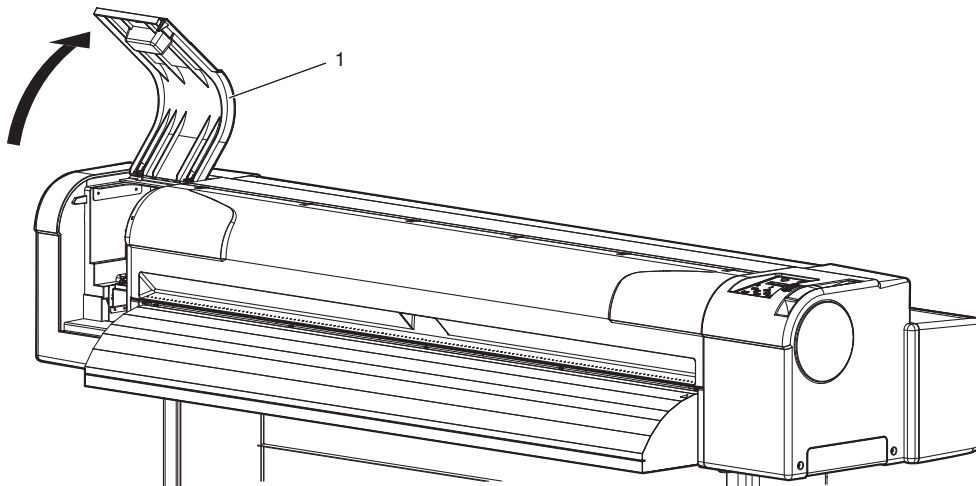

No.	Name
1	Maintenance cover

- "Set white plate then close mainte. cover." is displayed on the operation panel.

9. Remove the white reference plate from the plate installation place, turn it over so that the white side faces up, and install it back to the original place.

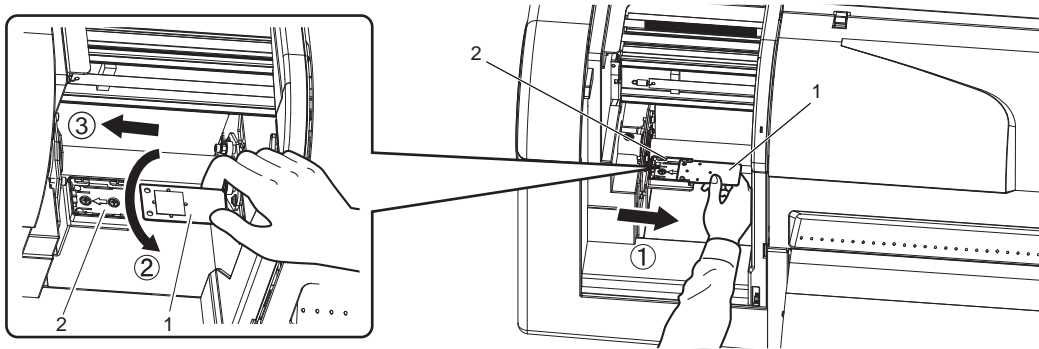

No.	Name
1	White reference plate
2	Plate installation place

NOTE

- Before measuring the color patches, make sure that the white side of the white reference plate is facing up. If the black side is facing up, it will not be measured correctly.

10. Close the maintenance cover.

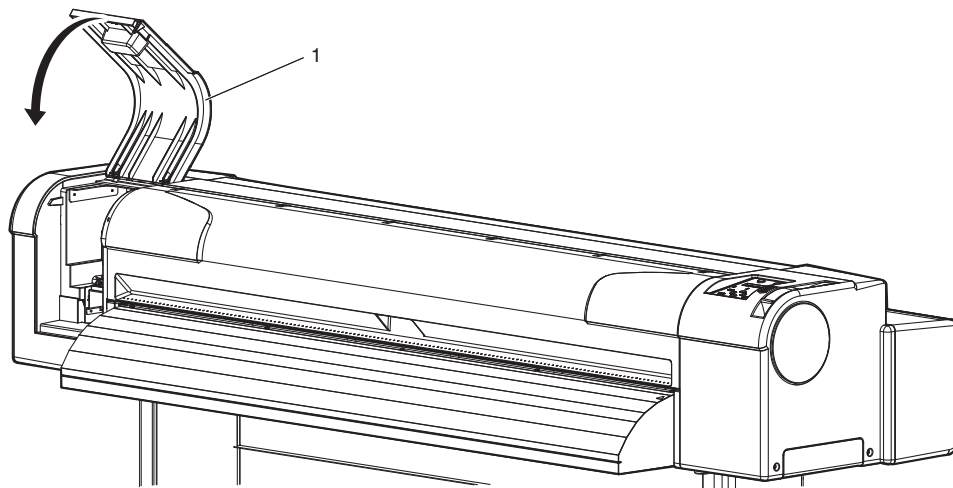

No.	Name
1	Maintenance cover

- "Open front cover." is displayed on the operation panel.

11. Open the front cover.

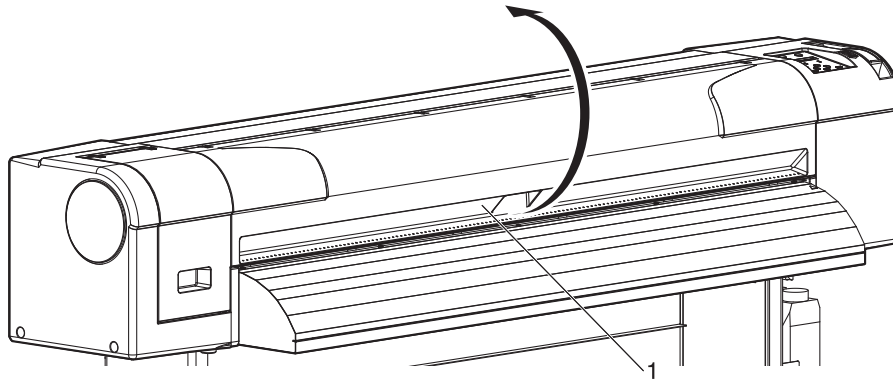

No.	Name
1	Front cover

- "Remove connector cap and attach instrument [ENTER]" is displayed on the operation panel.

12. Firmly pinch the tabs on both sides of the connector cap with your fingers, pull the connector cap forward to remove it from the print head.

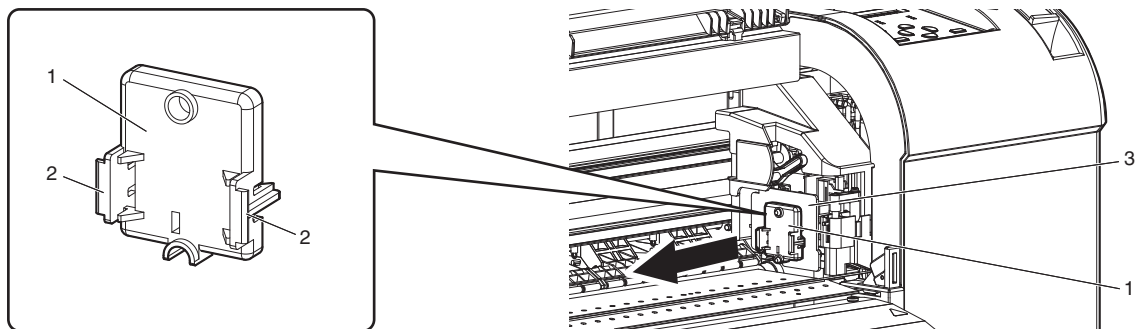

No.	Name
1	Connector cap
2	Tabs
3	Print head section

13. Press the release buttons on both sides of spectrophotometer, install it to the connector at the print head.

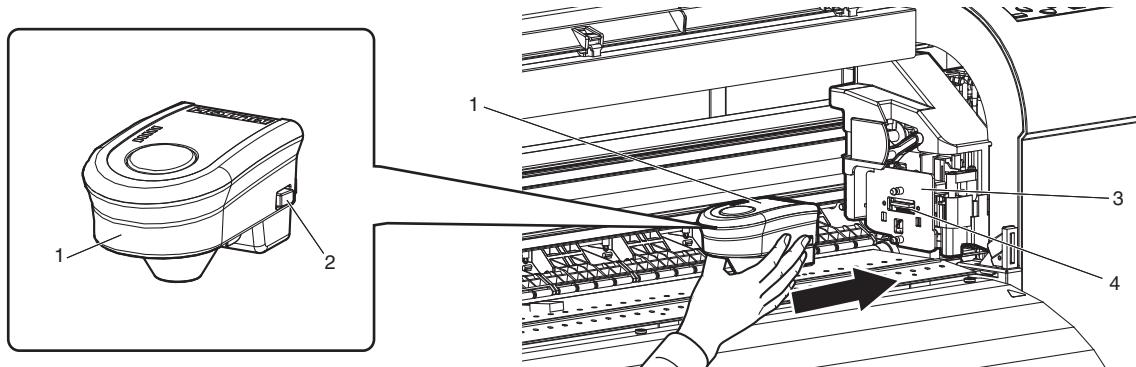

No.	Name
1	Spectrophotometer
2	Release buttons
3	Print head section
4	Connector

NOTE

- Make sure that spectrophotometer is NOT installed at an angle, and that there is no gap between the connector and spectrophotometer.

14. Press the [Enter] key.

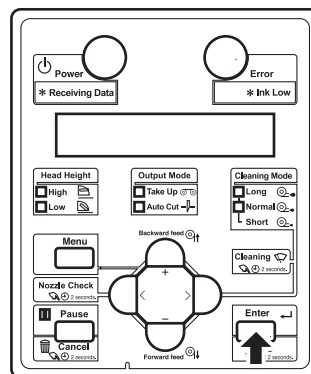

- The printer checks the connection between the printer and spectrophotometer.
- "Close front cover" is displayed on the operation panel.

15. Close the front cover.

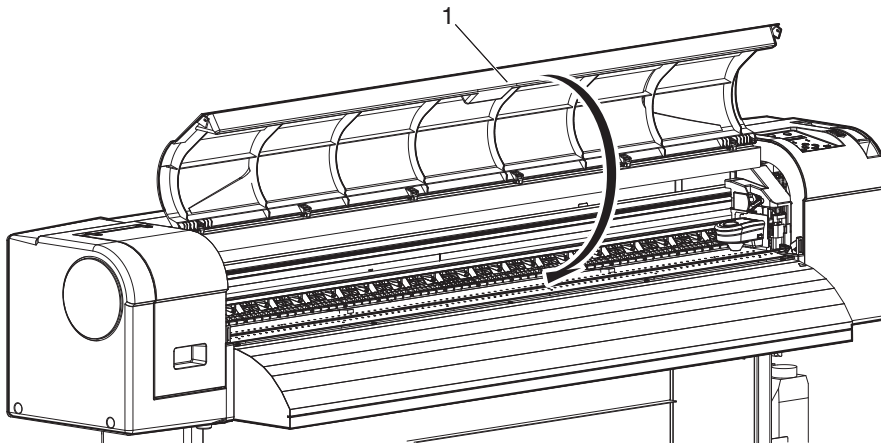

No.	Name
1	Front cover

- "Wait for a while..." is displayed on the operation panel.
- The printer starts white calibration.

16. When "Start measurement [ENTER]" is displayed on the operation panel, press the [Enter] key.

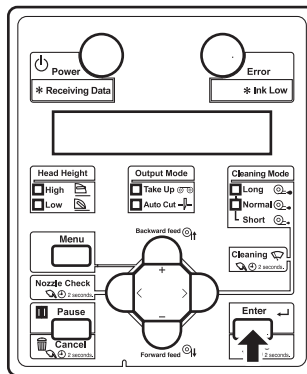

- Spectrophotometer starts measuring the color patches.
- "Measuring..." is displayed on the operation panel.
- After measuring is complete, "Detaching instrument [ENTER]" is displayed on the operation panel.

NOTE

- Do not open the covers or move media loading lever during measuring.

17. Press the [Enter] key.

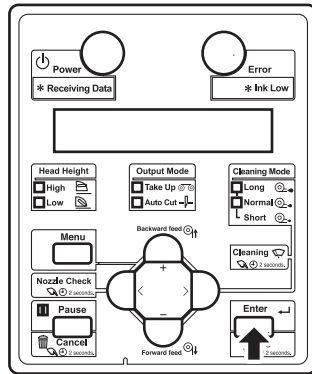

- "Open front cover." is displayed on the operation panel.

18. Open the front cover.

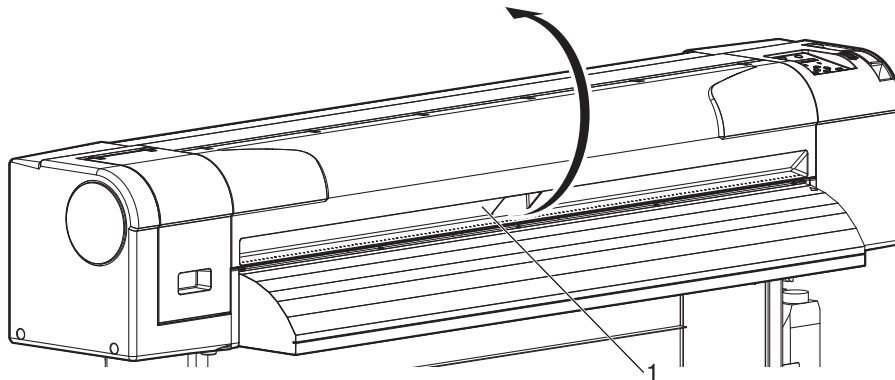

No.	Name
1	Front cover

- "Detach instrument and Set connector [ENTER]" is displayed on the operation panel.

19. While pressing the release buttons on both sides of spectrophotometer, pull it forward to remove it from the print head.

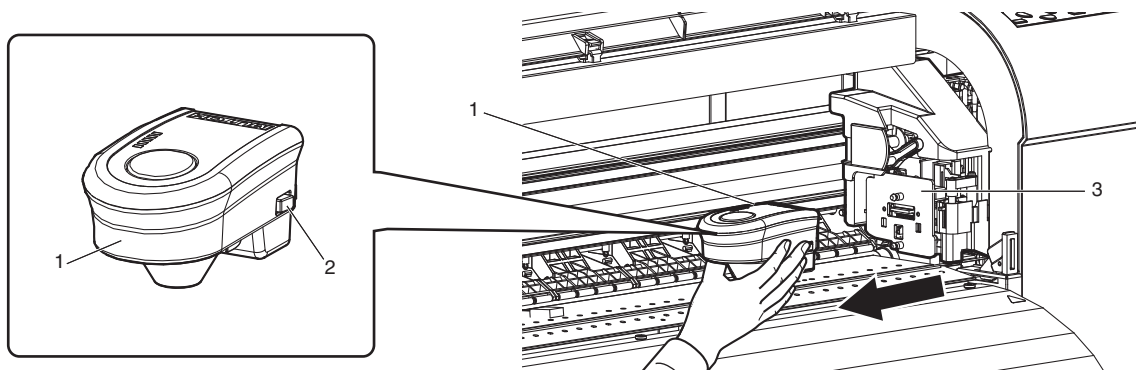

No.	Name
1	Spectrophotometer
2	Release buttons
3	Print head section

20. Firmly pinch the tabs on both sides of the connector cap with your fingers, and install it to the connector at the print head.

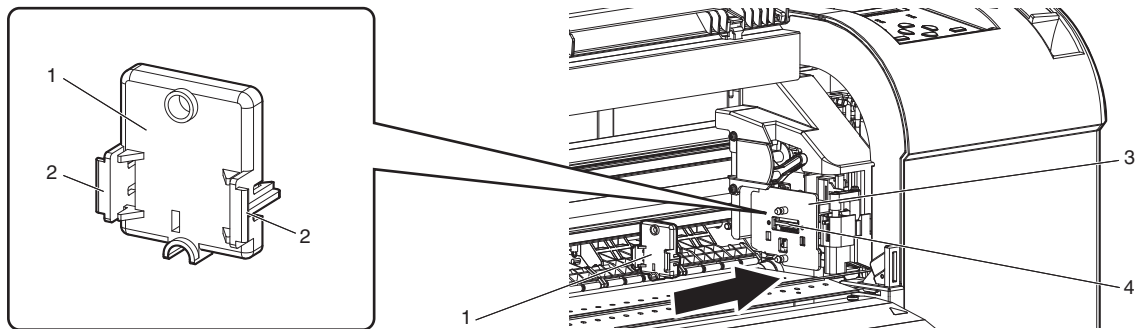

No.	Name
1	Connector cap
2	Tabs
3	Print head section
4	Connector

21. Press the [Enter] key.

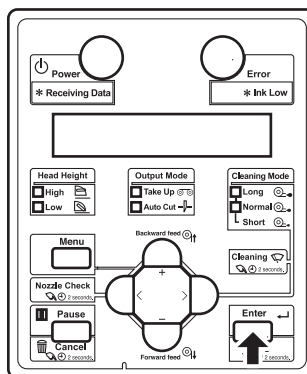

- "Wait for a while..." is displayed on the operation panel.
- Make sure that the connector cap is installed on the printer.
- "Close front cover" is displayed on the operation panel.

22. Close the front cover.

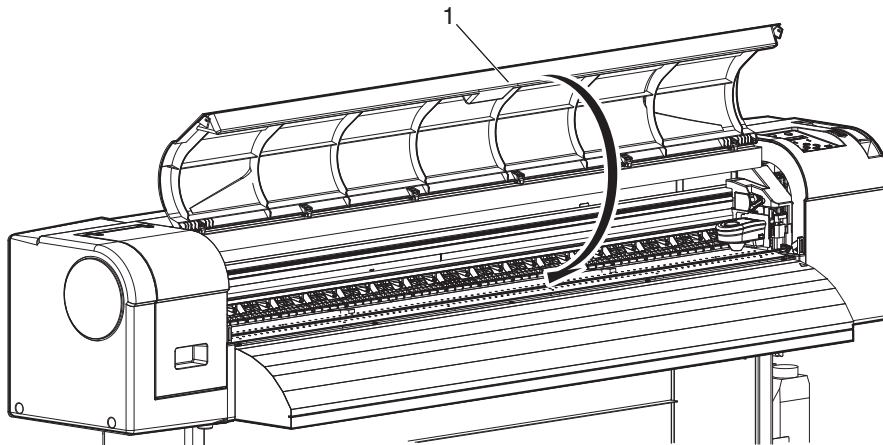

No.	Name
1	Front cover

- "Open mainte. cover." is displayed on the operation panel.

23. Open the maintenance cover.

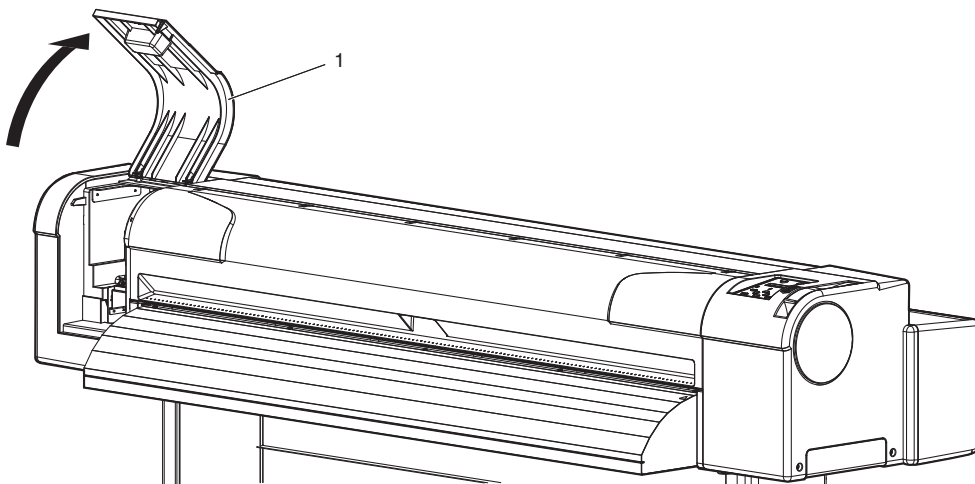

No.	Name
1	Maintenance cover

- "Remove white plate then close mainte. cover." is displayed on the operation panel.

24. Remove the white reference plate from the plate installation place, turn it over so that the black side faces up, and install it back to the original place.

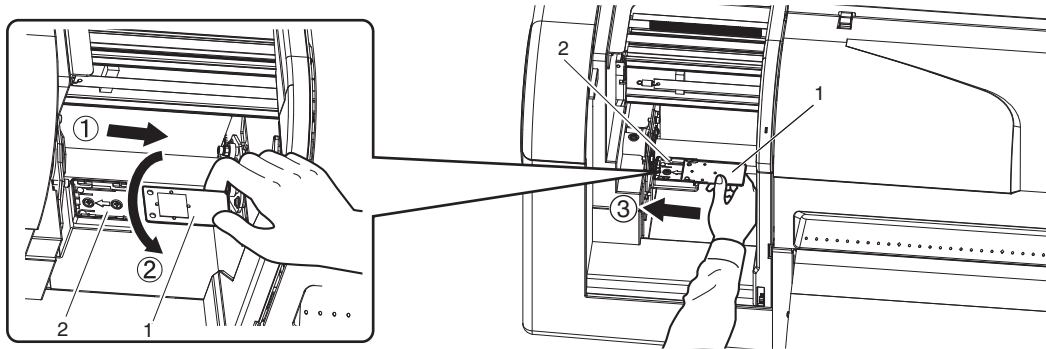

No.	Name
1	White reference plate
2	Plate installation place

NOTE

- When the white reference plate is not in use, make sure that it is turned over facing down to avoid any contamination.

25. Close the maintenance cover.

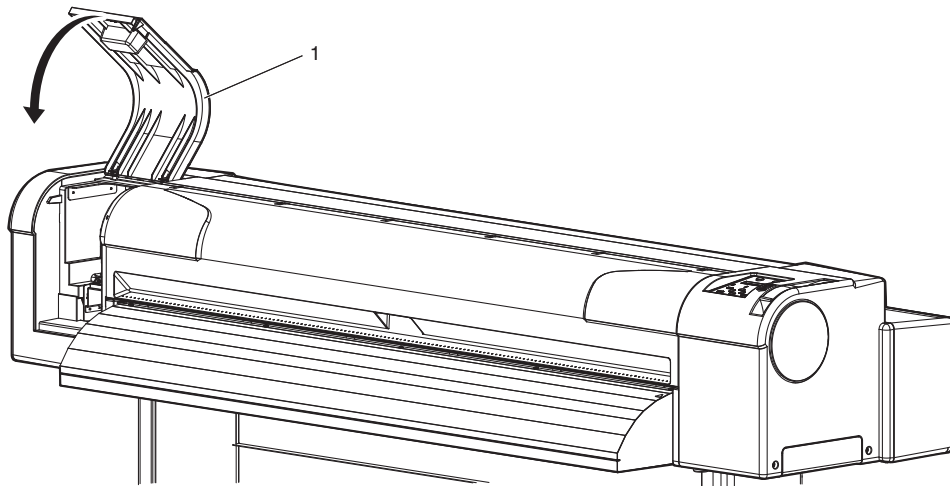

No.	Name
1	Maintenance cover

- The printing of following items starts.
 - Date
 - Serial Number
 - Color Difference (dE)

Color Verification

2011/11/01 15:25
Serial No. = XXXXXXXXXX

0.6 0.2 0.6 0.1 0.5 0.6 0.6 1.1 1.2 0.2 0.1 0.4 0.3 0.3

User Type = Type 3 Pre Heater = 42°C Head Temp. = 25°C dE < 1.0: No discernable difference in color.
 Praten Heater = 42°C Dryer = 42°C dE < 3.2: Minimally discernable color difference for colors viewed side-by-side.
 dE < 3.2: Minimally discernable color difference for colors in close proximity, not side-by-side.

No.	Name
1	Date
2	Serial Number
3	Color Difference (dE)

26. Check the color difference (dE).

Followings are the commonly recognized indications of color difference (dE).

- dE < 1.0: No discernable difference in color.
- dE < 3.2: Minimally discernable color difference for colors viewed side-by-side.
- dE < 6.5: Minimally discernable color difference for colors in close proximity, not side-by-side.

NOTE

- In order to perform the Color Verify correctly, make sure to specify the following settings same as the setting when the baseline was saved. If these settings are different, the color difference may become large.
- Each Heater Temperature Setting, Effect Setting, CR Print Width Setting, Overwrite Setting
- Since the room environment (temperature, humidity) may affect the print color, create the environment in accordance with the environment condition described in this manual "8.1.1 Printer specifications" "Environment Condition". In addition, make sure to place the media and ink in the printing environment for 2 hours before use.
- "Color Verify" is a function to check the color variation in print color caused by various causes. This function is not to guarantee the color reproducibility of the printer.
- Since the judgment of color acceptance is largely dependent on the human eye, we recommend to perform the print to check the color.

- The message "Update Result?" is displayed on the operation panel.

27. Press [Enter] key to save the measurement value of the currently printed color patches.

NOTE

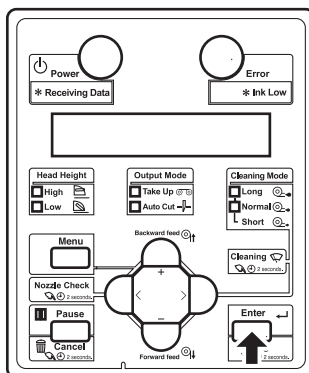

- When the measurement value is saved, the baseline will be replaced by the currently measured value.
- Press [Cancel] key to not to save the measurement value.



- "Ready to Print" is displayed on the operation panel.

3.6 Adjust Print

It is used for optimizing the quality of image prints.
This printer has the following adjustment methods.



Adjustment method	Description	Reference
Standard	Adjusts only the print mode in the user type setting which is currently set.	 3.6.1 Standard Adjust Print
Custom	Adjusts all print modes.	 3.6.2 Custom Adjustment Pattern

NOTE



- This printer was adjusted at the factory shipment so that it obtains the optimum printing quality. Adjust the quality if the print quality changes after the installation environment or the media is changed.
- If you change the user type settings after performing Standard Adjust Print, make sure to perform Adjust Print.
- When performing Custom adjust print, the print modes are adjusted all at once. Therefore, you do not need to perform print adjustment even when the user type setting has been newly set or changed.
- When using RIP software, etc, and setting the resolution which is different from the setting in the user type setting, make sure to perform adjustment for all print modes by Custom Adjust Print.

3.6.1 Standard Adjust Print

Adjusts only the print mode in the user type setting which is currently set.
This menu is made up with the following menus.

Menu Name	Description	Reference
Standard Confirmation Pattern	Print the confirmation pattern and check the amount of misalignment.	 3.6.1.1 Standard Confirmation Pattern
Standard Rough Adjustment Pattern	Perform this adjustment when the misalignment is big.	 3.6.1.2 Standard Rough Adjustment Pattern
Standard Micro Adjustment Pattern	Perform this adjustment when the misalignment is small.	 3.6.1.3 Standard Micro Adjustment Pattern

Follow the procedure below to adjust print quality.

1. Print the confirmation pattern and check the amount of misalignment.
 [3.6.1.1 Standard Confirmation Pattern](#)
2. Perform rough adjustment when the misalignment is big.
 [3.6.1.2 Standard Rough Adjustment Pattern](#)
Perform micro adjustment when the misalignment is small.
 [3.6.1.3 Standard Micro Adjustment Pattern](#)

NOTE

- Perform rough adjustment first when the amount of misalignment cannot be judged.

3. Print the confirmation pattern and check if the printer is adjusted properly.
 [3.6.1.1 Standard Confirmation Pattern](#)
4. If the printer is not adjusted, go back to Step 2.

NOTE

- When you are not satisfied with the result of rough adjustment, perform micro adjustment.

3.6.1.1 Standard Confirmation Pattern

Print the confirmation pattern for the print mode in the user type setting which is currently set.

1. Turn ON the printer and load the roll media.
 - [3.4.2 Setting Roll Media](#)
2. Display the Adjust Print menu on the operation panel.
 - a. Press the [Menu] key on the operation panel.

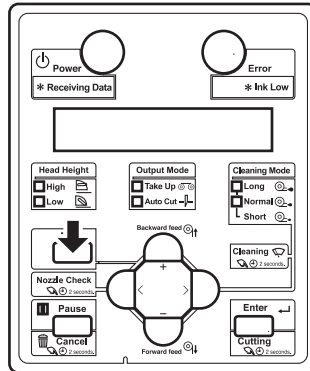

- "Menu1: Setup>" is displayed on the operation panel.
 - The operation panel shifts to the Setup menu display.
- b. Press the [+] key or [-] key to select "Set 1: User Type".

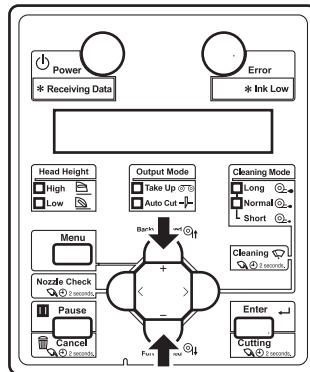

- c. Press the [Enter] key on the operation panel.

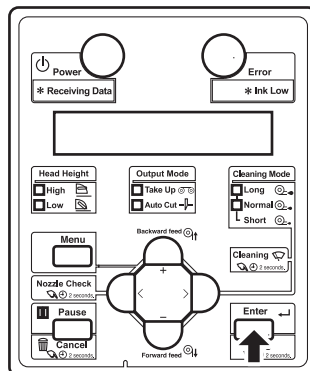

- "User: TypeXX" (XX is a number between 1 and 30) is displayed on the operation panel.

- d. Press the [+] key or [-] key to select the type of media to load.
- e. Press the [Enter] key on the operation panel.

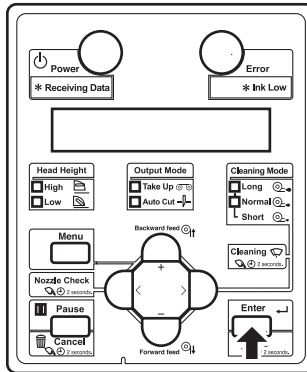

- "**>1: Print Mode" is displayed on the operation panel.
- f. Press the [+] key or [-] key to select "**>2: Adjust Print>".

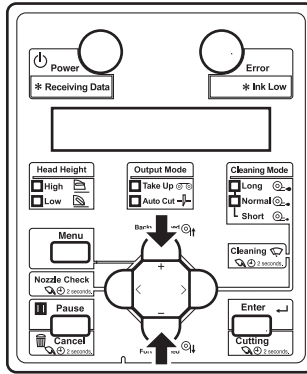

- g. Press the [>] key on the operation panel.

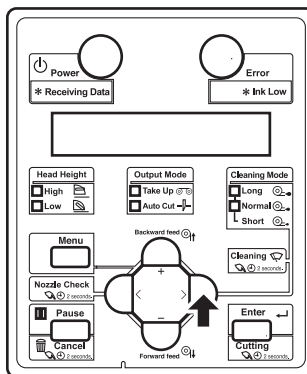

- "Adj.Print1: Standard" is displayed on the operation panel.

- h. Press the [+] key or [-] key to select "Adj.Print1: Standard>".

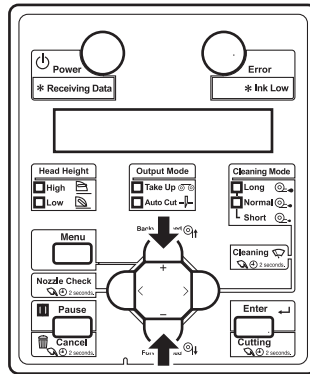

- i. Press the [Enter] key on the operation panel.

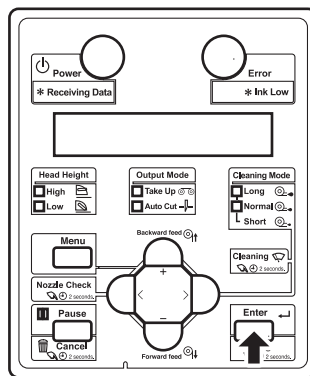

- "Adj.1: Confirm Ptn." is displayed on the operation panel.
- The display enters the Adjust Print menu.

5.1.1.1.3 Adjust Print menu

3. Press the [Enter] key on the operation panel.

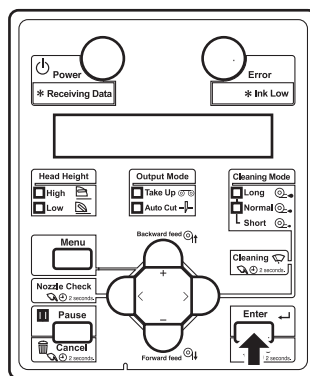

- "Warming Up", and then "Warming Up Skip -> E" are displayed.

NOTE

- To start printing during warming up, press the [Enter] key while "Warming Up Skip -> E" is displayed.

 [4.4.7 Start Printing during Warm up](#)

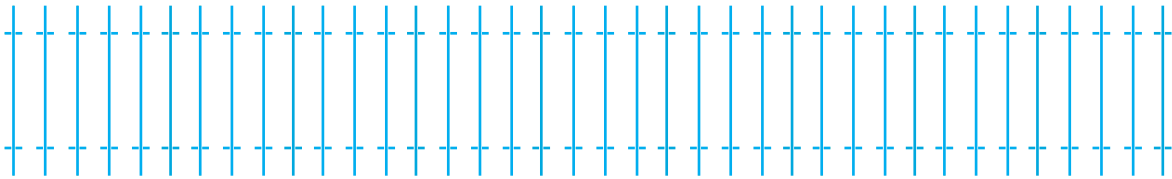

- A confirmation pattern for print quality adjustment is printed after warming up.
- A confirmation pattern is printed.

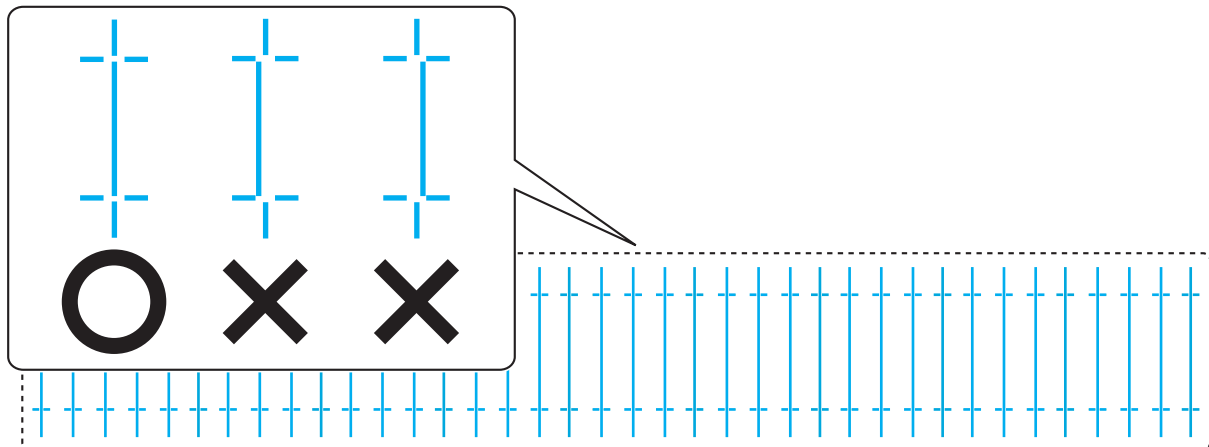

- After the confirmation pattern is printed, "Adj.1: Confirm Ptn." is displayed on the operation panel.

4. Confirm that the confirmation pattern printing result is as follows.



- When the printing result is OK;
You do not need perform Adjust Print.
The procedure for Adjustment is complete.
- When the printing result is ×:
you need to perform Alignment.
 - Perform rough adjustment when the misalignment is big.
 [3.6.1.2 Standard Rough Adjustment Pattern](#)
 - Perform micro adjustment when the misalignment is small.
 [3.6.1.3 Standard Micro Adjustment Pattern](#)

3.6.1.2 Standard Rough Adjustment Pattern

Check the confirmation pattern, and when the misalignment is big, perform rough adjustment. Print a rough adjustment pattern and register the setting value.

1. Display the Adjust Print menu on the operation panel in the same way as in step 2 of "3.6.1.1 Standard Confirmation Pattern"
2. Press the [+] key or [-] key to select "Adj.2: Rough Pattern".

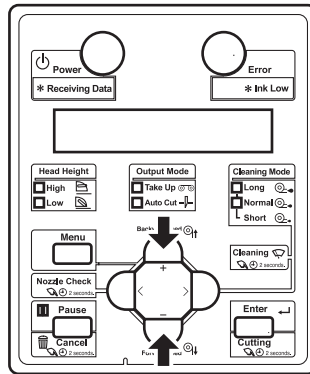

3. Press the [Enter] key on the operation panel.

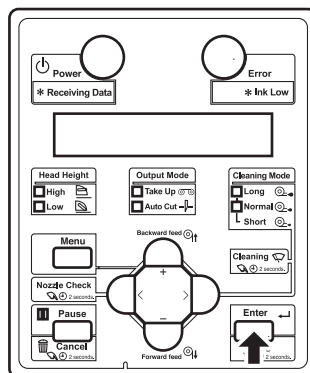

- The printer starts printing a rough adjustment pattern.
- The pattern images are printed on both paper edges and the center of the media.

4. Check the both ends and the center of the print result that printed with Adjust pattern, and select the number from 1 to 11 that is not out of alignment.
 - "4" is selected in the next printing sample.

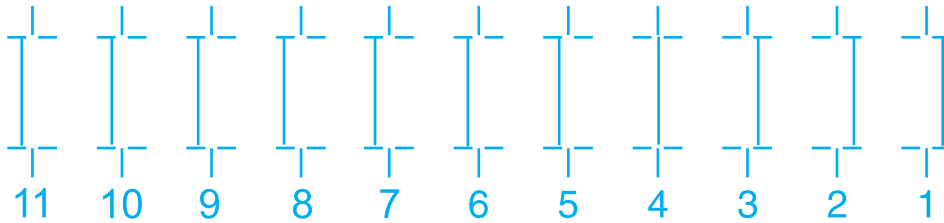

NOTE

- "6" is the current setting value.

5. "Pattern *: 6" (* indicates a pattern name as shown below) is displayed on the operation panel.
 - The pattern name (*) differs depending on the set print mode. The print modes and their pattern names are as follows.

PrintMode	PatternName
Quality 1, 2	C
Quality 3, 4	B
Graphics 1, 2	E
Graphics 3, 4	D
Banner 1, 2	A
Banner 3, 4	A

6. Press the [+] key or [-] key to enter the number that you selected in Step 4.

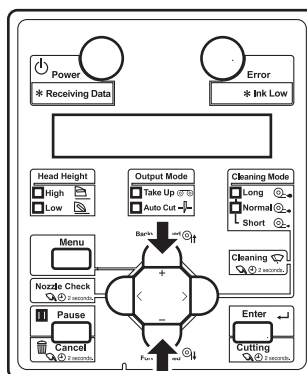

NOTE

- When you press the [Cancel] key, the input operation is not executed and "Adj.2: Rough Pattern" is displayed on the operation panel.

7. Press the [Enter] key on the operation panel.

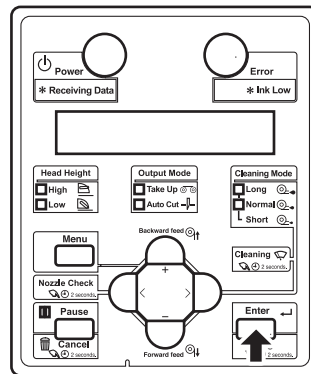

- The value is set in the "Adjustment: *" (* indicates a number from 1 to 11).
- The operation panel display returns to "Adj.2: Rough Pattern".

3.6.1.3 Standard Micro Adjustment Pattern

Check the confirmation pattern, and when the misalignment is small, perform micro adjustment. Print a micro adjustment pattern and register the setting value.

1. Display the Adjust Print menu on the operation panel in the same way as in step 2 of "3.6.1.1 Standard Confirmation Pattern"
2. Press the [+] key or [-] key to select "Adj.3: Fine Pattern".

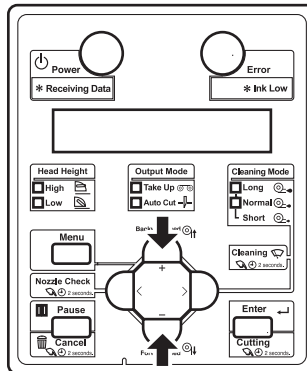

3. Press the [Enter] key on the operation panel.

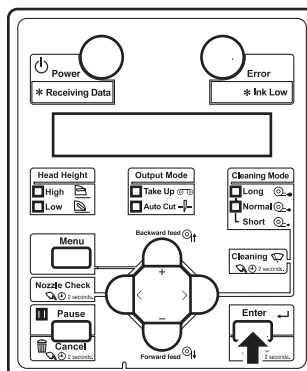

- "Warming Up", and then "Warming Up Skip -> E" are displayed.

NOTE

- To start printing during warming up, press the [Enter] key while "Warming Up Skip -> E" is displayed.

4.4.7 Start Printing during Warm up

- A confirmation pattern for print quality adjustment is printed after warming up.
- Regarding adjust print patterns, the same patterns are printed on both edges and the center of the paper.

4. Check the both ends and the center of the print result that printed with Adjust pattern, and select the number from 1 to 7 that is not out of alignment.
 - "6" is selected in the next printing sample.

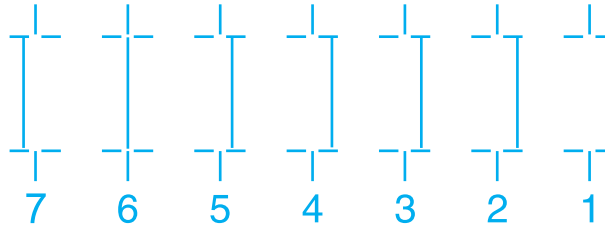

NOTE

- "4" is the current setting value.

5. "Pattern *: 4" (* indicates a pattern name as shown below) is displayed on the operation panel.
 - The pattern name (*) differs depending on the set print mode. The print modes and their pattern names are as follows.

PrintMode	PatternName
Quality 1, 2	C
Quality 3, 4	B
Graphics 1, 2	E
Graphics 3, 4	D
Banner 1, 2	A
Banner 3, 4	A

6. Press the [+] key or [-] key to enter the number that you selected in Step 4.

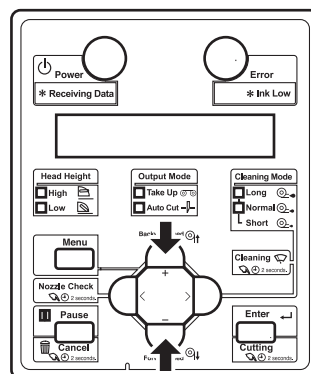

NOTE

- When you press the [Cancel] key, the input operation is not executed and "Adj.3: Fine Pattern" is displayed on the operation panel.

7. Press the [Enter] key on the operation panel.

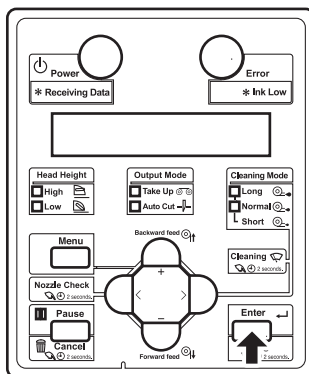





- The value is set in the "Pattern: *" (* indicates a number from 1 to 7).
- The operation panel display returns to "Adj.3: Fine Pattern".

3.6.2 Custom Adjustment Pattern

All patterns from A to F can be adjusted.

By performing this adjustment, all print modes will be adjusted.

This menu is made up with the following menus.

Menu Name		Description	Reference
Custom Confirmation Pattern		Print the confirmation patterns A to F and check the amount of misalignment.	 3.6.2.1 Custom Confirmation Pattern
Custom Rough Adjustment Pattern		Perform this adjustment when the misalignment is big. Adjust all confirmation patterns A to F.	 3.6.2.2 Custom Rough Adjustment Pattern
Custom Micro Adjustment Pattern	Adj. PatternALL	Perform this adjustment when the misalignment is small. Adjust all confirmation patterns A to F.	 3.6.2.3.1 Adj. PatternALL
	Each Adjust Patterns	Perform this adjustment when the misalignment is small. Adjust all confirmation patterns A to F.	 3.6.2.3.2 Each Adjust Patterns

Follow the procedure below to adjust print quality.

1. Print the confirmation pattern and check the amount of misalignment.

 [3.6.2.1 Custom Confirmation Pattern](#)

2. Perform rough adjustment when the misalignment is big.

 [3.6.2.2 Custom Rough Adjustment Pattern](#)

Perform micro adjustment when the misalignment is small.

 [3.6.2.3 Custom Micro Adjustment Pattern](#)

NOTE

- Perform rough adjustment first when the amount of misalignment cannot be judged.

3. Print the confirmation pattern and check if the printer is adjusted properly.

 [3.6.2.1 Custom Confirmation Pattern](#)

4. If the printer is not adjusted, go back to Step 2.

NOTE

- When you are not satisfied with the result of rough adjustment, perform micro adjustment.
- For Micro Adjustment Pattern, select "Adjust pattern ALL" to adjust all patterns or "Each Adjust pattern" to adjust patterns A to F separately.

 [3.6.2.3.1 Adj. PatternALL](#)

 [3.6.2.3.2 Each Adjust Patterns](#)

3.6.2.1 Custom Confirmation Pattern

From this menu, you can print all confirmation patterns A to F to check the amount of misalignment.

1. Turn ON the printer and load the roll media.
 - ☞ [3.4.2 Setting Roll Media](#)
2. Display the Adjust Print menu on the operation panel.
 - a. Press the [Menu] key on the operation panel.

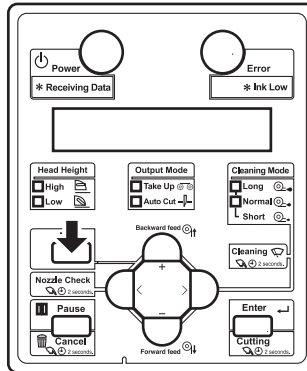

- "Menu1: Setup>" is displayed on the operation panel.
 - The operation panel shifts to the Setup menu display.
- b. Press the [+] key or [-] key to select "Set 1: User Type".

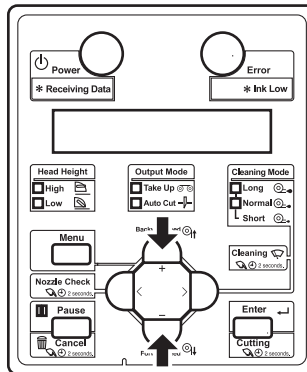

- c. Press the [Enter] key on the operation panel.

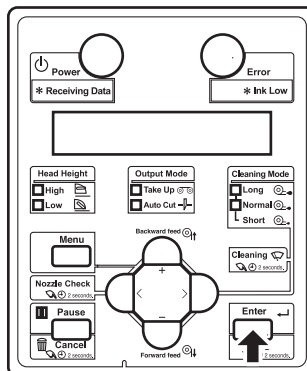

- "User: TypeXX" (XX is a number between 1 and 30) is displayed on the operation panel.

- d. Press the [+] key or [-] key to select the type of media to load.
- e. Press the [Enter] key on the operation panel.

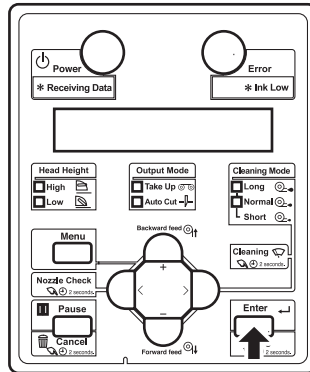

- "**>1: Print Mode" is displayed on the operation panel.
- f. Press the [+] key or [-] key to select "**>2: Adjust Print>".

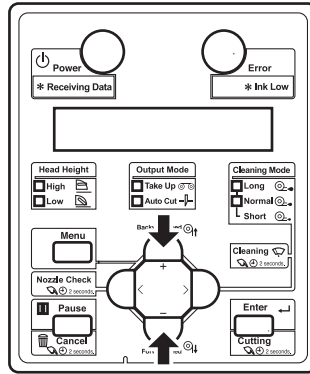

- g. Press the [>] key on the operation panel.

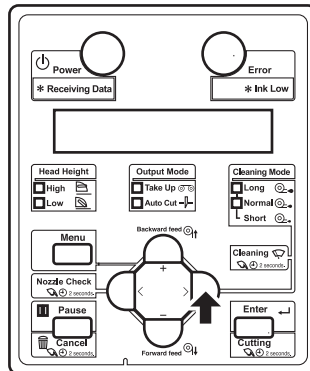

- "Adj.Print1: Standard" is displayed on the operation panel.

- h. Press the [+] key or [-] key to select "Adj.Print2: Custom>".

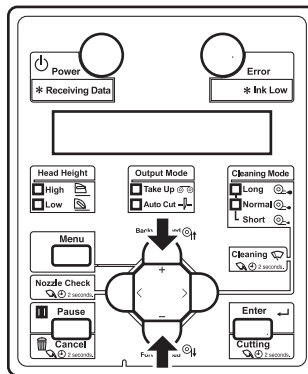

- i. Press the [Enter] key on the operation panel.

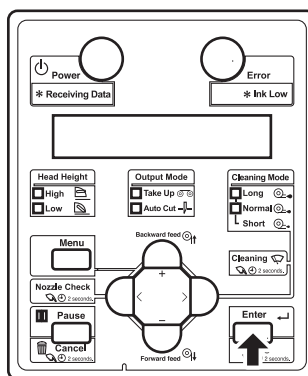

- "Adj.1: Confirm Ptn." is displayed on the operation panel.
- The display enters the Adjust Print menu.

5.1.1.1.3 Adjust Print menu

3. Press the [Enter] key on the operation panel.

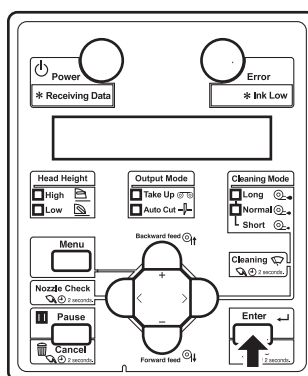

- "Warming Up", and then "Warming Up Skip -> E" are displayed.

NOTE

- To start printing during warming up, press the [Enter] key while "Warming Up Skip -> E" is displayed.

 **4.4.7 Start Printing during Warm up**

- A confirmation pattern for print quality adjustment is printed after warming up.
- Six confirmation patterns of A to F will be printed.

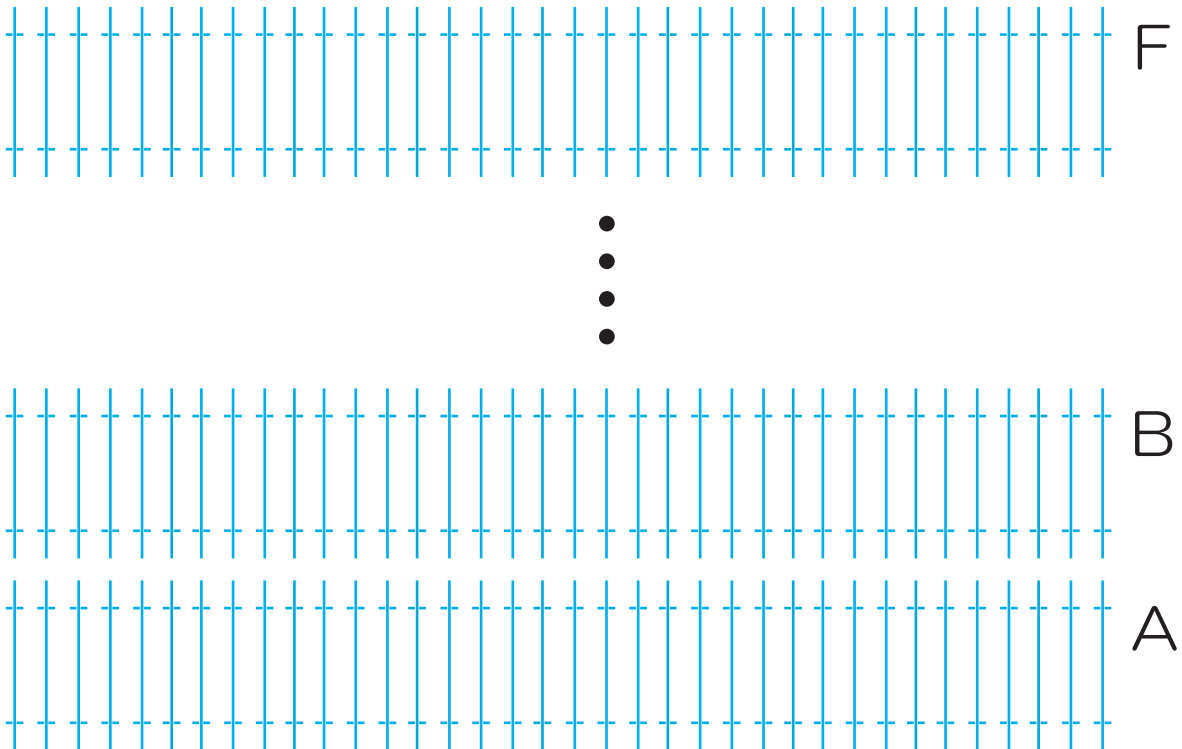

- After the confirmation pattern is printed, "Adj.1: Confirm Ptn." is displayed on the operation panel.

4. Confirm that the confirmation pattern printing result is as follows.

- Check each of the confirmation patterns A to F.

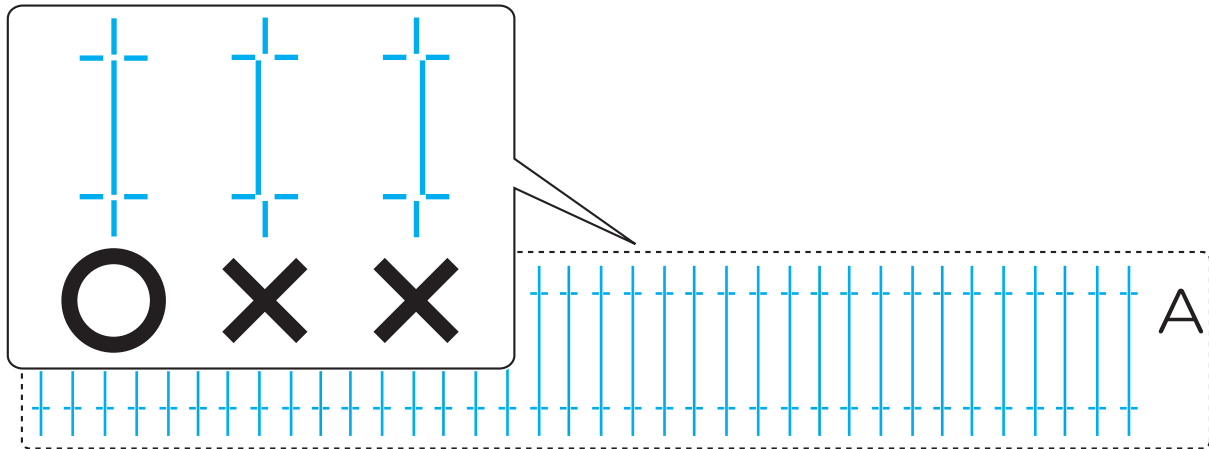

- When the printing result is OK;
You do not need perform Adjust Print.
The procedure for Adjustment is complete.
- When the printing result is ×:
you need to perform Alignment.
 - Perform rough adjustment when the misalignment is big.
👉 [3.6.2.2 Custom Rough Adjustment Pattern](#)
 - Perform micro adjustment when the misalignment is small.
 - When all patterns A to F require adjustment: 👉 [3.6.2.3.1 Adj. PatternALL](#)
 - When any pattern of A to F requires adjustment: 👉 [3.6.2.3.2 Each Adjust Patterns](#)

3.6.2.2 Custom Rough Adjustment Pattern

Check the confirmation pattern, and when the misalignment is big, perform rough adjustment. Print a rough adjustment pattern and register the setting value.

1. Display the Custom Adjust Print menu on the operation panel in the same way as in step 2 of "[3.6.2.1 Custom Confirmation Pattern](#)"
2. Press the [+] key or [-] key to select "Adj.2: Rough Pattern".

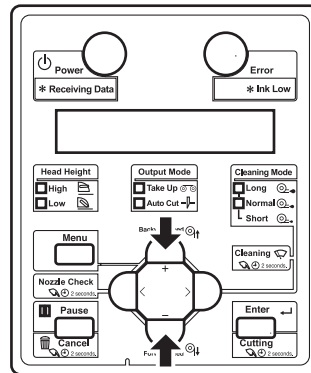

3. Press the [Enter] key on the operation panel.

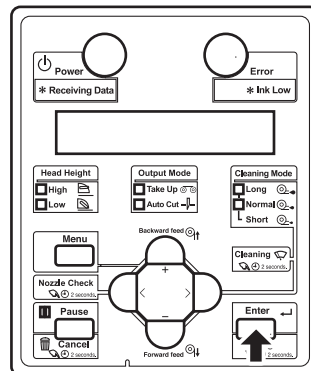

- "Warming Up", and then "Warming Up Skip -> E" are displayed.

NOTE

- To start printing during warming up, press the [Enter] key while "Warming Up Skip -> E" is displayed.

[4.4.7 Start Printing during Warm up](#)

- A rough adjustment pattern for print quality adjustment is printed after warming up.
- The pattern images are printed on both paper edges and the center of the media.
- Six rough adjustment patterns will be printed. Input setting value for each pattern.

4. Check the both ends and the center of the print result that printed with Adjust pattern, and select the number from 1 to 11 that is not out of alignment.
 - "3" is selected in the next printing sample of "Micro Adjustment Pattern A".
 - "5" is selected in the next printing sample of "Micro Adjustment Pattern B".
 - "4" is selected in the next printing sample of "Micro Adjustment Pattern F".

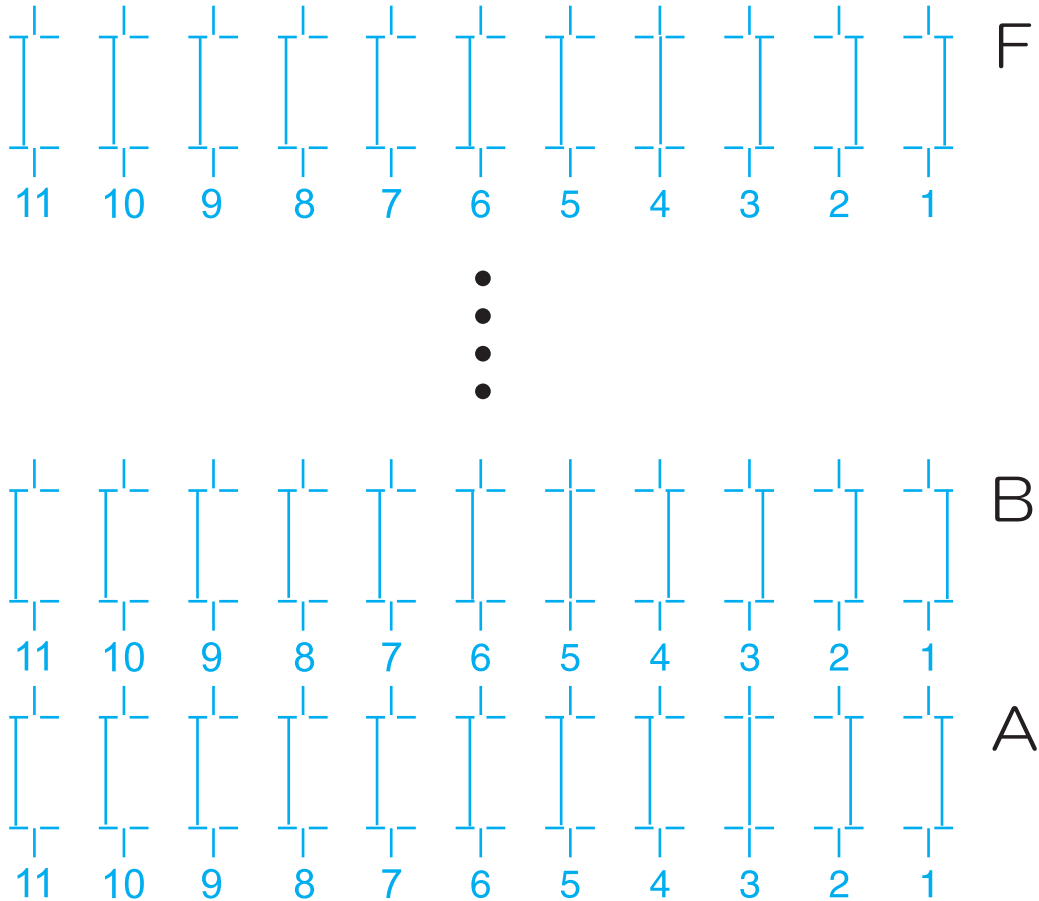

NOTE

- "6" is the current setting value.

5. "PatternA: 6" is displayed on the operation panel.

6. Press the [+] key or [-] key to enter the number that you selected in Step 4.

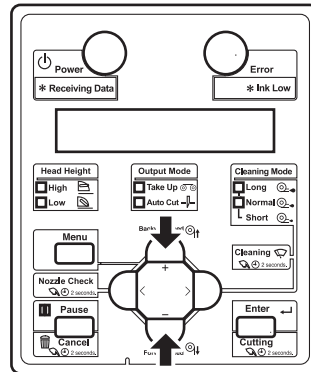

NOTE

- When you press the [Cancel] key, the input operation is not executed and "Adj.2: Rough Pattern" is displayed on the operation panel.

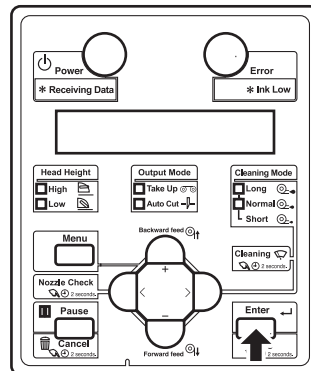

7. Press the [Enter] key on the operation panel.



- The value is set in the "Pattern A: *" (* indicates a number from 1 to 11).
8. In the same way, enter the numbers for "Patterns B" to "Pattern F".
- Press the [Enter] key to set the values.
 - Once all set values have been entered, press the [Enter] key to register the set values of "Pattern A" to "Pattern F" to the printer.
 - The operation panel display returns to "Adj.2: Rough Pattern".

3.6.2.3 Custom Micro Adjustment Pattern

Check the confirmation pattern, and when the misalignment is small, perform micro adjustment. This menu is made up with the following menus.

Menu Name		Description	Reference
Custom Micro Adjustment Pattern	Adj. PatternALL	Adjust all confirmation patterns A to F.	 3.6.2.3.1 Adj. PatternALL
	Each Adjust Patterns	Adjust all confirmation patterns A to F.	 3.6.2.3.2 Each Adjust Patterns

3.6.2.3.1 Adj. PatternALL

Print a Micro Adjustment Pattern ALL and register the setting value.

1. Display the Custom Adjust Print menu on the operation panel in the same way as in step 2 of "[3.6.2.1 Custom Confirmation Pattern](#)"
2. Press the [+] key or [-] key to select "Adj.3: Fine Ptn. ALL".

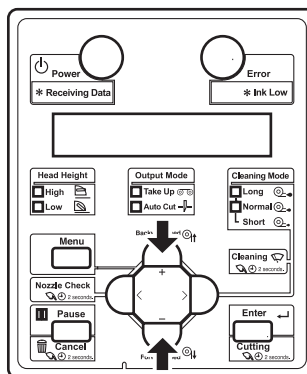

3. Press the [Enter] key on the operation panel.

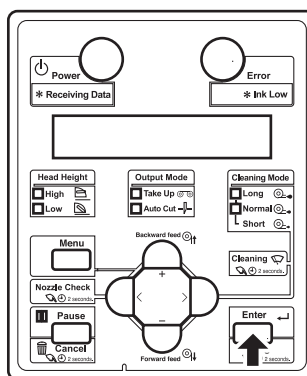

- "Warming Up", and then "Warming Up Skip -> E" are displayed.

NOTE

- To start printing during warming up, press the [Enter] key while "Warming Up Skip -> E" is displayed.

 **4.4.7 Start Printing during Warm up**

- An Adjust print pattern for print quality adjustment is printed after warming up. Six micro adjustment patterns will be printed. Input setting value for each pattern.
 - Regarding adjust print patterns, the same patterns are printed repeatedly on both edges and the center of the paper.
4. Check the both ends and the center of the print result that printed with Adjust pattern, and select the number from 1 to 7 that is not out of alignment.
- "3" is selected in the next printing sample of "Micro Adjustment Pattern A".
 - "5" is selected in the next printing sample of "Micro Adjustment Pattern B".
 - "6" is selected in the next printing sample of "Micro Adjustment Pattern F".

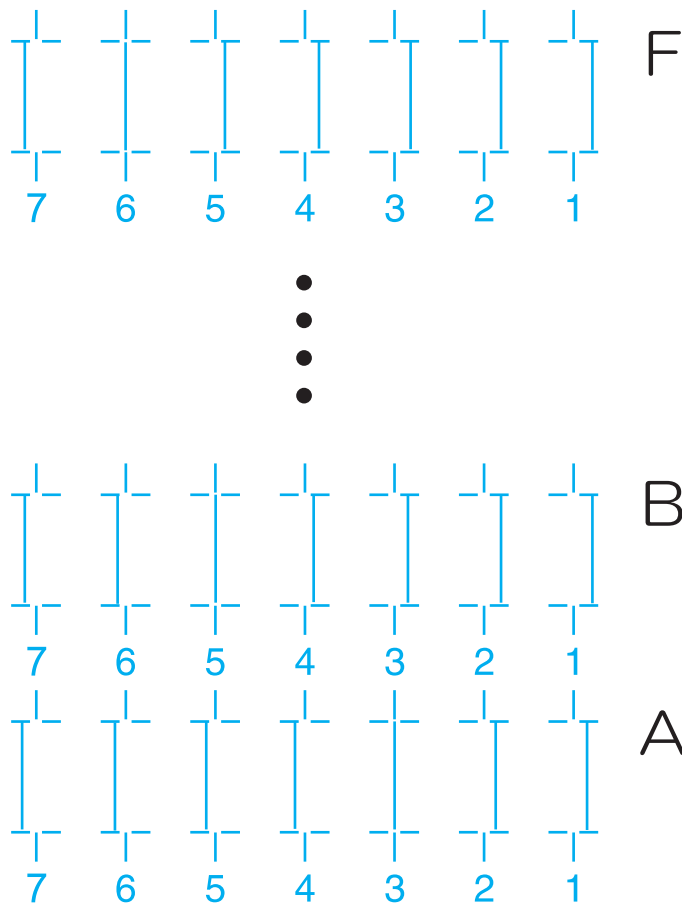

NOTE

- "4" is the current setting value.

5. "PatternA: 4" is displayed on the operation panel.
6. Press the [+] key or [-] key to enter the number that you selected in Step 4.

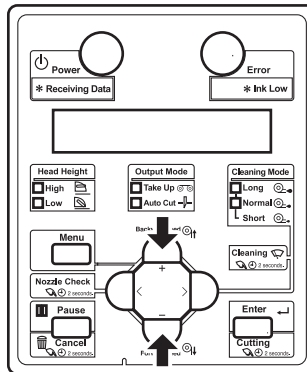
**NOTE**

- When you press the [Cancel] key, the input operation is not executed and "Adj.3: Fine Ptn. ALL" is displayed on the operation panel.

7. Press the [Enter] key on the operation panel.

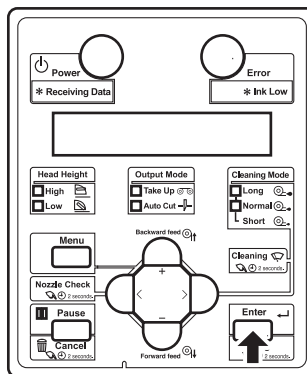

- The value is set in the "Pattern A: *" (* indicates a number from 1 to 7).
8. In the same way, enter the numbers for "Patterns B" to "Pattern F".
 - Press the [Enter] key to set the values.
 - Once all set values have been entered, press the [Enter] key to register the set values of "Adjust Pattern A" to "Adjust Pattern F" to the printer.
 - The operation panel display returns to "Adj.3: Fine Ptn. ALL".

3.6.2.3.2 Each Adjust Patterns

Select and print one of the adjust patterns A to F and register the set value.
Follow the procedures below to adjust "Pattern A" only.

1. Display the Custom Adjust Print menu on the operation panel in the same way as in step 2 of "[3.6.2.1 Custom Confirmation Pattern](#)".
2. Press the [+] key or [-] key to select "Adj.4: Fine PatternA".

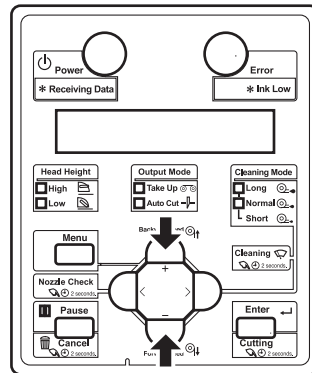

3. Press the [Enter] key on the operation panel.

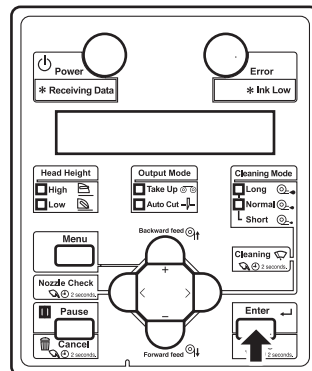

- "Warming Up", and then "Warming Up Skip -> E" are displayed.

NOTE

- To start printing during warming up, press the [Enter] key while "Warming Up Skip -> E" is displayed.

[4.4.7 Start Printing during Warm up](#)

- An Adjust print pattern for print quality adjustment is printed after warming up.
- Regarding adjust print patterns, the same patterns are printed repeatedly on both edges and the center of the paper.

4. Check the both ends and the center of the print result that printed with Adjust pattern, and select the number from 1 to 7 that is not out of alignment.
 - "6" is selected in the next printing sample.

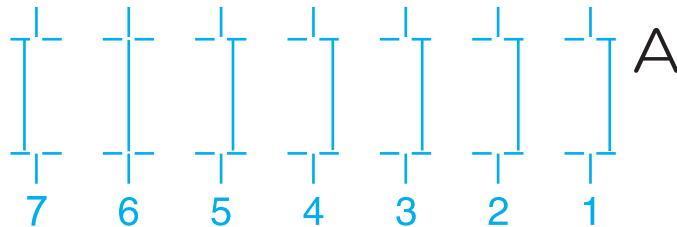
**NOTE**

- "4" is the current setting value.

5. "PatternA: 4" is displayed on the operation panel.
6. Press the [+] key or [-] key to enter the number that you selected in Step 4.

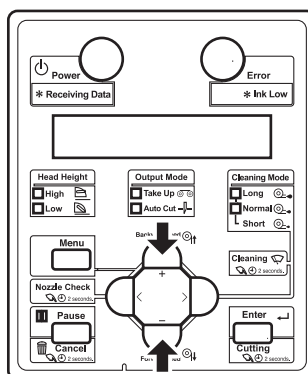
**NOTE**

- When you press the [Cancel] key, "Adj.4: Fine PatternA" is displayed on the operation panel.

7. Press the [Enter] key on the operation panel.

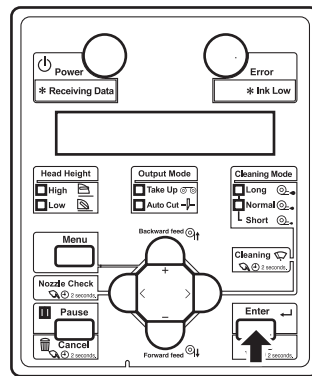

- The value is set in the "Pattern A: *" (* indicates a number from 1 to 7).
- Press the [Enter] key to register the setting value for "Fine PatternA" to the printer.
- The operation panel display returns to "Adj.4: Fine PatternA".

3.7 Connecting the printer to PC

This section explains how to connect the printer and a PC.

3.7.1 System requirements

The following are the system requirements for this printer.

Operating system	Windows7, Windows Vista, Windows XP
------------------	-------------------------------------

NOTE

- The required memory varies depending on the application software or the print data type.
- A large hard disk and memory are recommended.

3.7.2 Preparing cables

The printer is equipped with a network interface for connecting with a PC.

You need a network interface cable to connect a PC with this printer.

Prepare the cable depending on the PC that it will be connected to.

TIP

- About connecting a network interface cable, refer to "[3.7.3 Connecting a network interface cable](#)".
- For the recommended cable specifications, refer to "[8.2 Interface specification](#)".

3.7.3 Connecting a network interface cable

This section explains how to connect a network interface cable.

Follow the procedure below to connect this printer to your PC.

1. Turn OFF both the printer and PC.
2. Insert the network interface cable into the network interface connector located on the back of the printer.

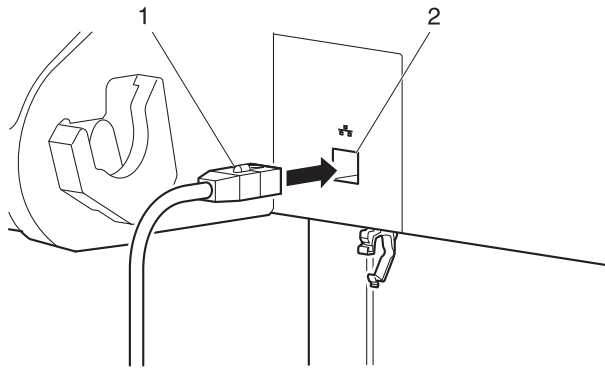

No.	Name
1	Network interface cable
2	Network interface cable connector

3. Fix the network interface cable to the cable clamp.

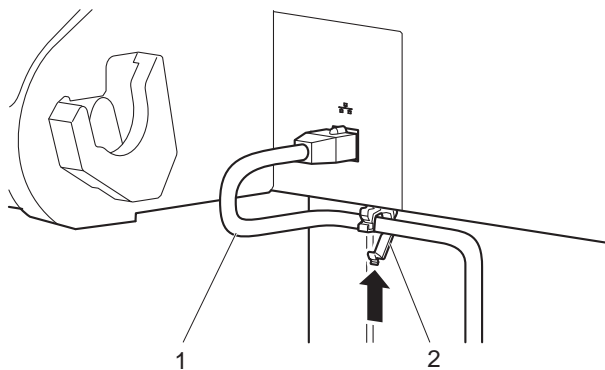

No.	Name
1	Network interface cable
2	Cable clamp

4. Connect the other connector of the network interface cable to your PC.

TIP

- About connecting to your PC, refer to the operation manual included with the PC.
- For network setting on the side of the printer, refer to "[4.3.2 Panel setup menu overview](#)".

4 Handling the printer

This chapter explains how to handle the printer.

4.1 Print flow chart

The following flow chart illustrates the procedure to perform printing with the printer. Refer to each section as required.

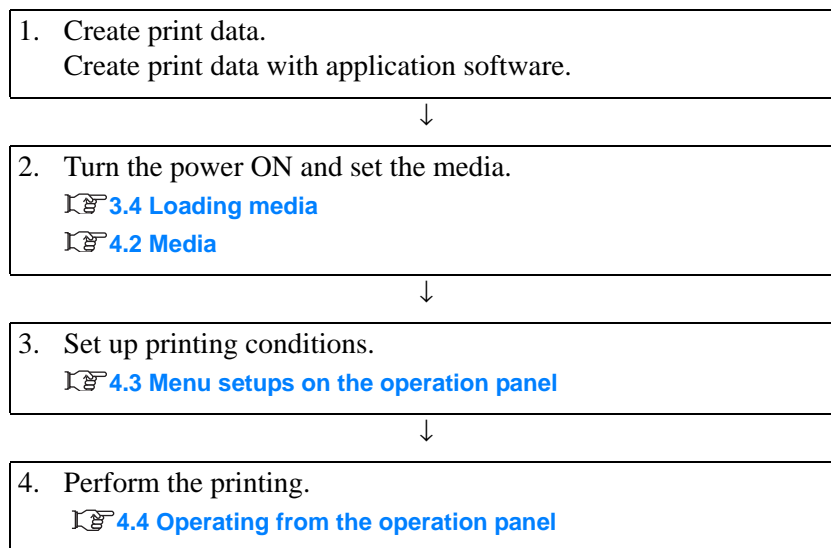

WARNING

- Do not place any combustible materials on the platen while the heater is working. There may be a risk of fire.
- Do not spill flammable liquid on the platen. This could lead to a fire.

CAUTION

- Do not touch the media guide while printing. The media guide becomes very hot and you could burn yourself.
- Do not touch the media feed slot, platen, and media guide while the heater is working. The media feed slot, platen, and media guide become very hot and you could burn yourself.
- Ventilate the workplace. Not doing so may make you feel sick or may lead to a fire.

NOTE

Do not open the front cover and maintenance cover during printing. If the front cover/maintenance cover is opened, printing will be interrupted. Printing restarts if you close the front cover/maintenance cover. However, the result of your print is not guaranteed.

4.2 Media

This section explains details of available media for this printer.

4.2.1 Media type

The type and quality of media greatly influence the print result. Use media that matches the application, taking the following information into account. Various recommended media are prepared for this printer as follows. Select the appropriate media according to the usage.

NOTE

- For details of the recommended media, contact your local MUTOH dealer.
- If failures or malfunctions of the printer occur by the use of media that is not dedicated:
- The printer will not be covered by the warranty and repair expenses will be paid by the customer.
- For details, refer to the following manuals.
 - ↳ [6 Maintenance](#)
 - ↳ [7 Troubleshooting](#)
- To request a repair, contact your local MUTOH dealer.

TIP

- When printing on media that is not recommended,
- Refer to the media manual or ask where you purchased the media for information on media types and appropriate settings for this printer.
- Set the print quality according to "[5.1.1 User Type menu](#)".

4.2.2 Cautions on handling media

Note the following points when handling the media.

NOTE

- Use recommended media under an appropriate environment.
The appropriate temperature and humidity for printing are as follows.

	Temperature	Humidity
Guaranteed range of printing accuracy	22°C to 30°C	40% to 60%
Change rate	Within 2°C per hour	Within 5 % per hour

- Do not use media which is folded, cut, or torn.
- The size of media can change according to changes in humidity in the printing environment. Before using media, leave media for 30 minutes in the printing environment to adapt it to the environment.
Performing printing without adapting media to the printing environment may cause media jams due to gaps or wrinkles in the media.
Print quality is also affected.
- When using the printer in a low-humidity environment, the cut media may stuck and may not come down. In such a case, open the front cover after the media is cut to remove the media.
- Do not touch the print side.
Moisture and oil on your hands may affect the print quality.
- Do not leave media set in the printer for a long time.
Some media has a tendency to bend, causing media jams and degradation of print quality.
Avoid using such media especially in winter, in dry conditions, and when printing formal documents.
- Do not discard the individual box and bag. Use them for storing media.

4.2.3 Precaution on storing media

Note the following points on storing media.

NOTE

- Avoid high temperature, high humidity, and direct sunlight when storing media.
- After removing the unused roll media from the scroller, wind it properly. Then wrap it with an individual bag and store it in an individual box.
- Keep the media dry.

4.2.4 Printing area

The printable area of this printer is as follows.

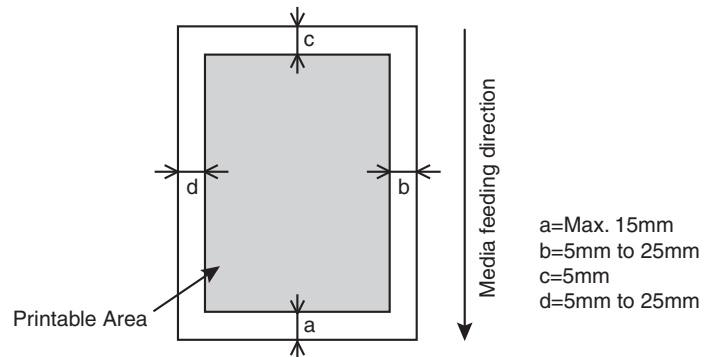

4.2.5 Head height adjustment

Printing with high printing rate or using strongly-curved media can cause print heads to rub. Changing the distance from the print head surface to media (head height) may allow you to avoid headrub.

Head height can be changed to two levels.
Follow the procedure below to change the head height.

4.2.5.1 When raising the print head

NOTE

- If the head height adjustment lever is raised, high print quality is not guaranteed.
- Do not open the front cover or change the head height during printing.
If the head height is changed, the alignment will be changed and high print quality will not be guaranteed.

1. Open the front cover.

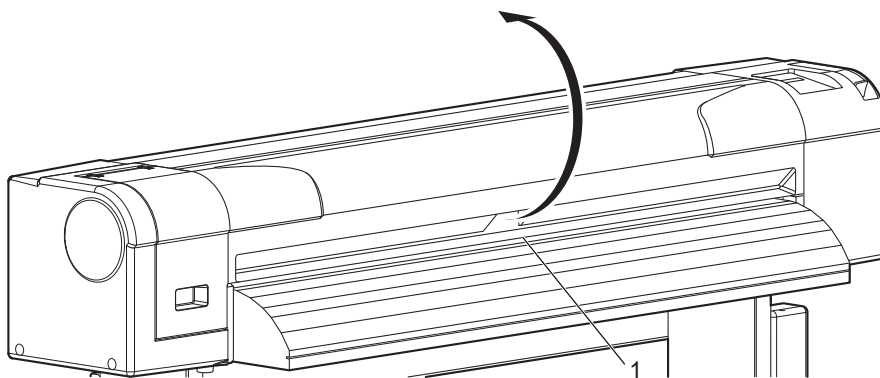

No.	Name
1	Front cover

2. Change the head height by moving the head height adjustment lever (orange).

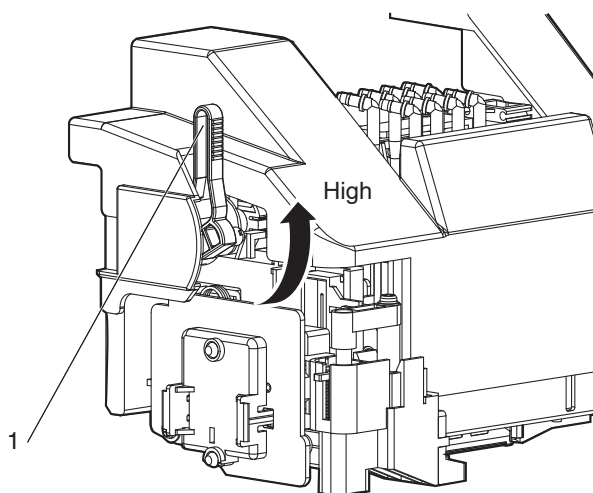

No.	Name
1	Head height adjustment lever

- The High lamp on the operation panel lights up in green.

3. Close the front cover.

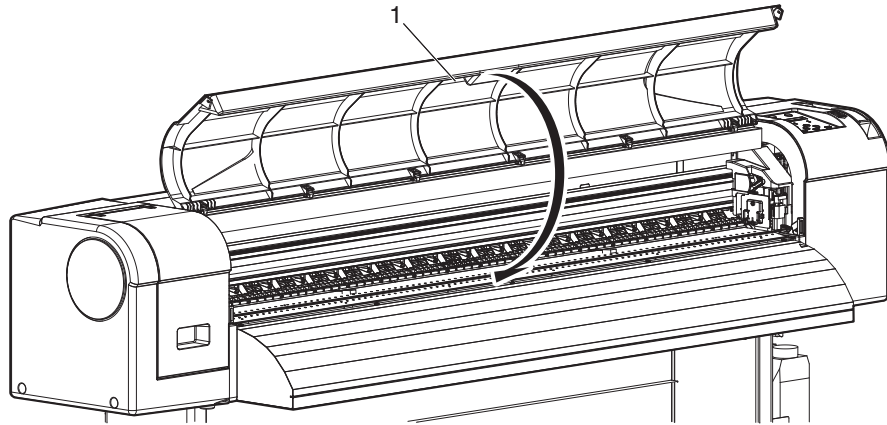

No.	Name
1	Front cover

4.2.5.2 When returning the print head to the original position

NOTE

- Do not open the front cover or change the head height during printing.
If the head height is changed, the alignment will be changed and high print quality will not be guaranteed.

1. Open the front cover.

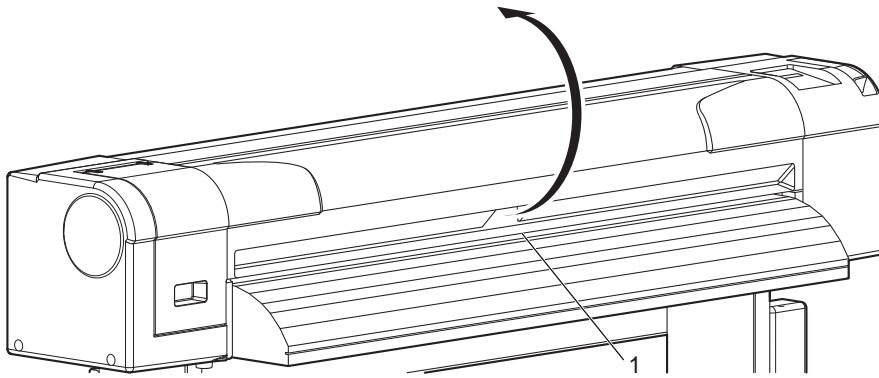

No.	Name
1	Front cover

2. Change the head height by moving the head height adjustment lever (orange).

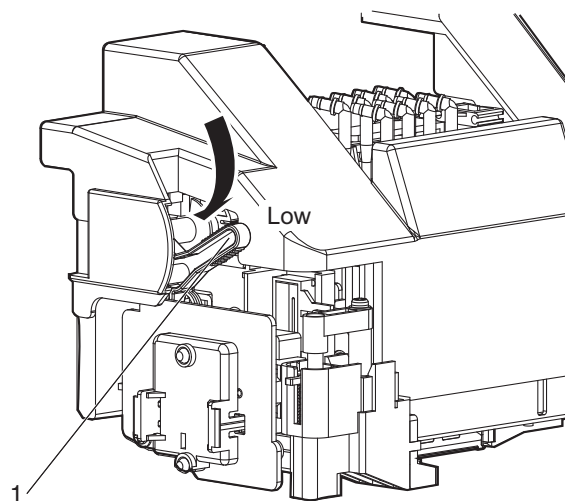

No.	Name
1	Head height adjustment lever

- The Low lamp on the operation panel lights up in green.

3. Close the front cover.

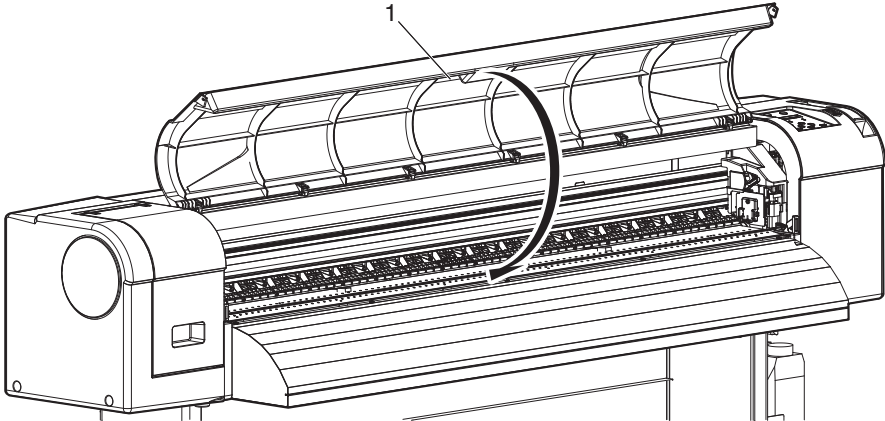

No.	Name
1	Front cover

4.2.6 Media feed compensation

This section explains the Media feed compensation.

The feeding length depends on the media type. The following or similar results may be seen in prints.

- Printed images overlap.
- White lines are printed on images.

The accuracy of media feeding may be improved with the following methods.

1. Display the Dist.Adj menu on the operation panel.
 - a. Press the [Menu] key on the operation panel.
 - "Menu1: Setup>" is displayed on the operation panel.
 - The operation panel shifts to the Setup menu display.
 - b. Press the [>] key on the operation panel.
 - "Set1: User Type" is displayed on the operation panel.
 - c. Press the [Enter] key on the operation panel.
 - "User: Type 1" is displayed on the operation panel.
 - d. Press the [+] key or [-] key on the operation panel to select the media type to use.
 - e. Press the [Enter] key on the operation panel.
 - "***>1: Print Mode" is displayed on the operation panel.

TIP

•The selected media (Type 1 to 30) is displayed in "***".

 [5.1.1 User Type menu](#)

- f. Press the [+] key or [-] key to select "***>3: PF Adjust>".
- g. Press the [>] key on the operation panel.
 - "PF1: Initial Print" is displayed on the operation panel.
 - Proceed to Dist.Adj menu.
 [5.1.1.1.4 Dist.Adj menu](#)

2. Performs Initial Print.

a. Press the [Enter] key on the operation panel.

- "Feed Length: 250 mm" is displayed on the operation panel.

TIP

- The length of media that is fed (feeding length) for Initial Print is normally set at 250 mm.
- If you increase the feeding length, the accuracy of the Media feed compensation improves.
To change the feeding length, press the [+] key or [-] key on the operation panel and change the set value.

b. Press the [Enter] key on the operation panel.

- "Printing" is displayed on the operation panel.
- Starts Initial Print.



No.	Name
1	Feed length
2	Media feeding direction

- When the Initial Print is complete, the printer enters Normal.

c. After the Initial Print, the media is cut.

🔗 [4.4.3 Cutting media](#)

3. Measure the distance between the two pluses in the Initial Print using a ruler.

4. Sets up Initial Adjust Change.
 - a. Press the [+] key or [-] key on the operation panel to select "PF2: Initial Change".
 - b. Press the [Enter] key on the operation panel.
 - "Init.: 250.0/250 mm" is displayed on the operation panel.
 - c. Press the [+] key or [-] key on the operation panel and enter the measured value in step 3.
 - d. Press the [Enter] key on the operation panel.
 - The initial adjustment value is saved.
 - "PF2: Initial Change" is displayed on the operation panel.
5. Performs Confirm Print.
 - a. Press the [+] key or [-] key on the operation panel to select "PF3: Confirm Print".
 - b. Press the [Enter] key on the operation panel.
 - "Feed Length: 250 mm" is displayed on the operation panel.

TIP

- The length of media that is fed (feeding length) for Confirm Print is normally set at 250 mm.
- If you increase the feeding length, the accuracy of the Media feed compensation improves.
- To change the feeding length, press the [+] key or [-] key on the operation panel and change the set value.

- c. Press the [Enter] key on the operation panel.
 - "Printing" is displayed on the operation panel.
 - Starts Confirm Print.



No.	Name
1	Feed length
2	Media feeding direction

- When the Confirm Print is complete, the printer enters Normal.

- d. After the Confirm Print, the media is cut.
 **4.4.3 Cutting media**
6. Measure the distance between the two pluses in the Confirm Print using a ruler. Then, confirm that the distance matches the feeding length when printing.
 - a. If the distance does not match the feeding length, follow the procedure from Step 1 to Step 5 and readjust.
 - b. If the distance matches the feeding length, proceed to step 7.
7. Perform Micro Print.
 - a. Display the Dist.Adj menu on the operation panel in the same way as in step 1.
 - b. Press the [+] key or [-] key on the operation panel to select "PF4: Micro Print".
 - c. Press the [Enter] key on the operation panel.
 - "Warming Up" and "Skip ->ENTER" are repeatedly displayed on the operation panel.
 - d. Wait till warming up process is complete, or press the [Enter] key on the operation panel to shift to the next operation.
 - "Printing" is displayed on the operation panel.
 - Starts Micro Print.

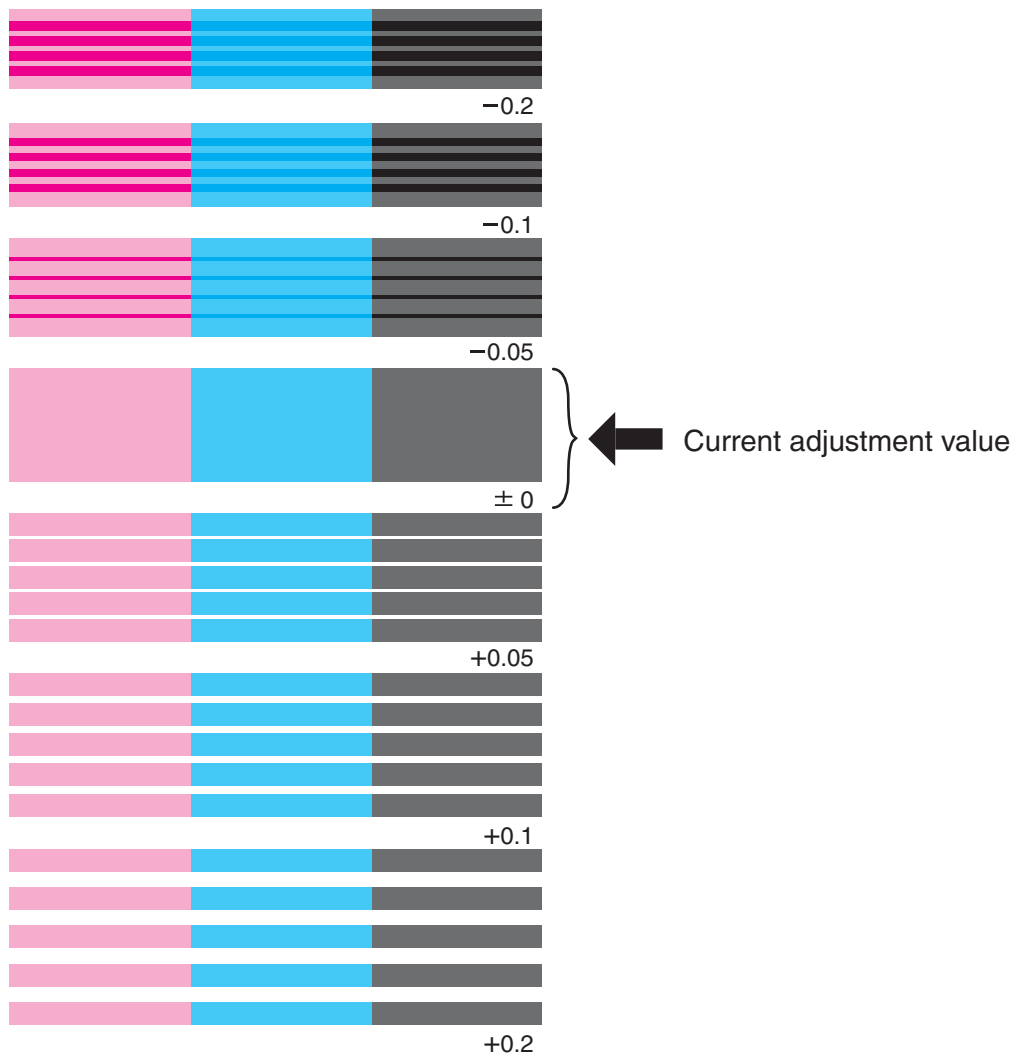

- After the micro adjustment printing is completed, "PF4:Micro Print" is displayed on the operation panel.

8. Refer to the illustrations below and check the printing result.

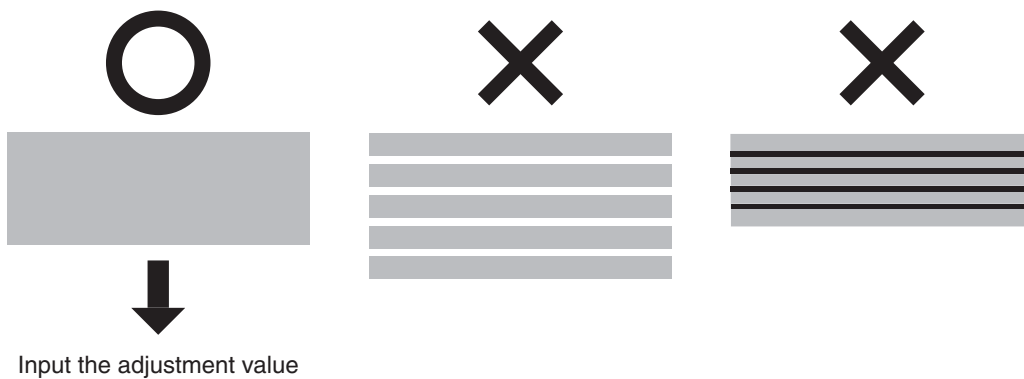

9. Sets up Micro Adjustment Change.
 - a. Press the [+] key or [-] key to select "PF5: Micro Change".
 - b. Press the [Enter] key on the operation panel.
 - "Micro Change: 0.00%" is displayed on the operation panel.
 - c. Press the [+] key or [-] key and enter the micro adjustment value according to the printing result in Step 7.
 - d. Press the [Enter] key on the operation panel.
 - The micro adjustment value is saved.
 - "PF5:Micro Change" is displayed on the operation panel.
10. Press the [Menu] key on the operation panel.
 - The operation panel returns to Normal.
 - The adjustment of media feed compensation value is complete.

4.3 Menu setups on the operation panel

4.3.1 Menu setup procedure

Follow the procedure below to configure each setup menu.

1. Confirm that the operation panel is Normal.
2. Press the [Menu] key on the operation panel.

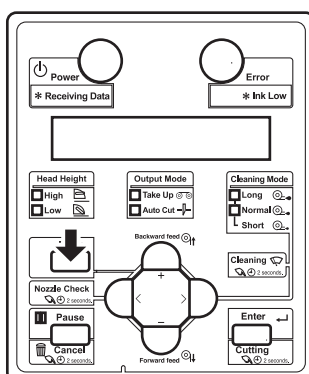

- "Menu1: Setup>" is displayed on the operation panel.
 - The operation panel shifts to the Setup menu display.
3. Press the [+] key or [-] key on the operation panel to select a setup item and press the [Enter] key.

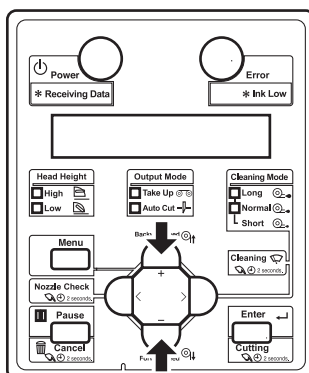

- The settings will be confirmed.
- When setup items have a submenu, the display shifts to the next menu.

NOTE

- When a setup item has a submenu, ">" is displayed on the right end of the LCD monitor of the operation panel.
- For the general outline of each setup item, refer to "[4.3.2 Panel setup menu overview](#)".

4. The setting in the blinking part on the LCD monitor of the operation panel can be changed. Press the [+] key or [-] key to change the set value.

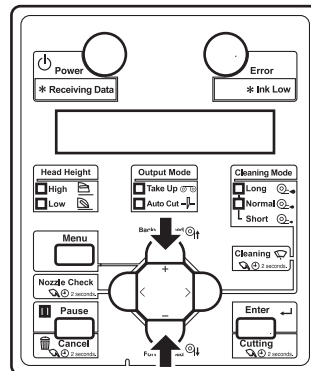

5. To save the changed setting, press the [Enter] key on the operation panel.

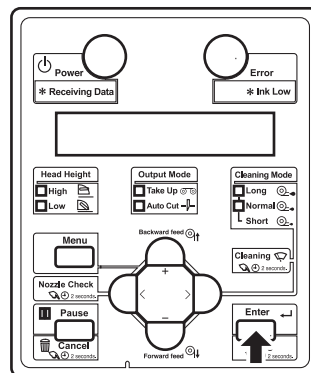

- The setting is saved and the next setup item is displayed.

NOTE

- If you press the [Cancel] key, [+] key or [-] key without pressing [Enter] key after changing a setting, the change will not be saved.

6. Press the [Cancel] key on the operation panel to exit from the setup.

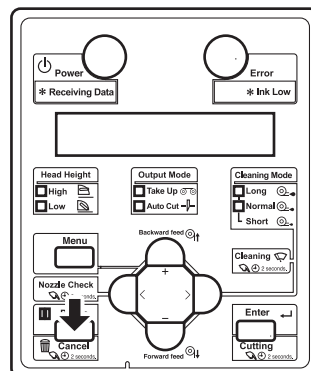

- The previous setup menu is displayed.
- When the main menu is displayed, the screen turns to Normal.

4.3.2 Panel setup menu overview

This section explains the Panel setup menu of the printer.
There are the following items in the Panel setup menu.

Setup item	Description
Setup menu	Various settings of the printer are configured.
Test Print menu	Performs nozzle check of the print head and setup list.
Cleaning menu	Performs head cleaning.
Menu Option menu	Sets up the contents of the Setup menu.
Version menu	Displays the versions of the firmware.
Sleep Mode menu	Sleep mode settings are configured.
Display menu	Sets the language and unit displayed on the LCD monitor of the operation panel.

TIP

- For details of each setup item, refer to "[5 Panel setup menu](#)".

4.4 Operating from the operation panel

This section explains various functions that can be operated from the operation panel.

TIP

- For names and functions of each key, refer to "[2.2.3 Operation panel](#)".

4.4.1 Feeding media

You can feed the roll media at a position that you want.

Follow the procedure below to feed media.

1. Confirm that the operation panel is Normal.
2. Make sure that the media loading lever is lowered.
3. Press the [Forward↓] key or the [Backward↑] key on the operation panel.

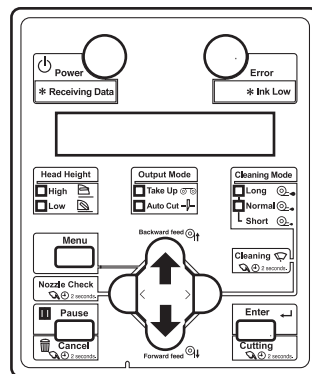

- Media is fed forward or backward.
4. Release the [Backward↑] key or [Forward↓] key on the operation panel after feeding media to the desired position.

4.4.2 Stopping printing operation

If you want to stop printing for some reason, operate as follows.

1. Stop sending printing data from the computer to the printer.
2. Press the [Cancel] key on the operation panel for two seconds.

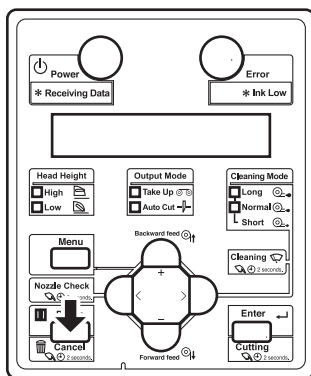

- The printer operates as follows.

Printer status	Operation with the [Cancel] key pressed for two seconds
During printing	Terminates the printing, and deletes one data remaining in the printer.
Receiving data/analyzing data	Deletes the data already received and converted.

NOTE

- If a large amount of data is saved on the printer, the operation panel may not return to Normal by a single [Cancel] key operation.
In such cases, wait for a few seconds and press the [Cancel] key again.

4.4.3 Cutting media

This section explains how to cut media.

If Media ejection mode is set to "Cut", the printer cuts the media automatically after printing.

☞ 5.1.6 Output Mode menu

If you press the [Cutting] key on the operation panel more than two seconds while the operation panel is Normal, you can cut the media at the desired position.

Follow the procedure below to cut the roll media.

1. Confirm that the operation panel is Normal.
2. Press the [Cutting] key on the operation panel for more than two seconds.

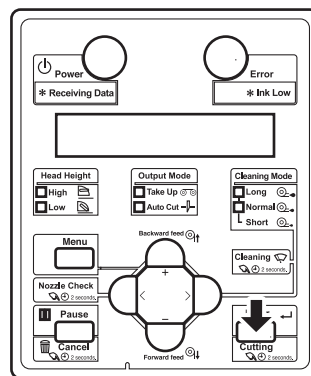

- The printer feeds the roll media to the length of the margin and cuts the media.

NOTE

- When loading the new roll media, cut the front edge of the media if it is not straight.
- The cutter is a consumable component. Replace it periodically.
- ☞ 6.1.3 Replacing Cutter
- When the media detection is set to "Off", the media cannot be cut automatically.

4.4.4 Cutting media manually

This section explains how to cut the roll media manually.

CAUTION

- **Right after printing, the media guide becomes very hot. Allow the media guide to cool down before the next operation.**

Follow the procedure below to cut the roll media.

1. Verify the following regarding the operational condition of the product.
 - Printing or other operations are not in progress.
 - The operation panel display is Normal.
2. To change the position to cut the roll media, refer to "[4.4.1 Feeding media](#)" and advance the roll media to the desired cut position.
3. Place a razor blade on the media cut groove on the media guide, and cut the roll media.

CAUTION

- **Pay attention to the following points when cutting roll media. Mishandling the razor blade may cause a cut on your finger or hand.**
- **When you hold media, do not place your finger on the media cut groove.**
- **Move the razor blade along the media cut groove.**

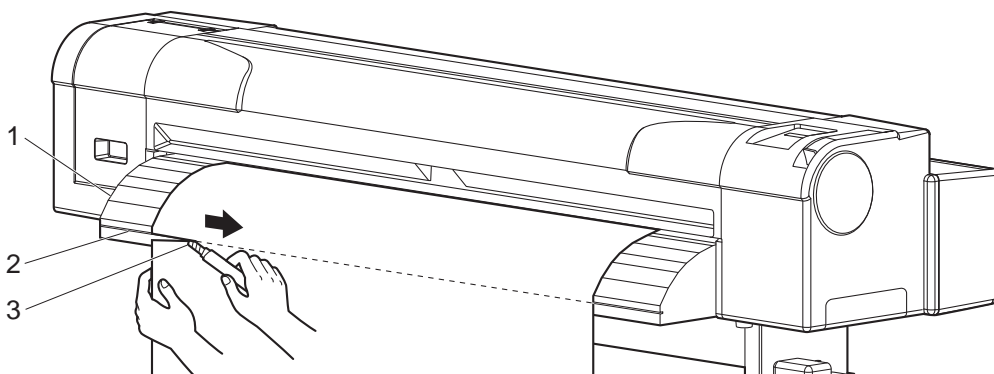

No.	Name
1	Media guide
2	Media cut groove
3	Razor blade

- The procedure for cutting the roll media is complete.

NOTE

- When loading the new roll media, cut the front edge of the media if it is not straight.

4.4.5 Changing and confirming settings while printing

While the printer is operating, you can change or confirm settings for the Panel setup menu.

4.4.5.1 Procedure for changing and confirming settings while printing

Follow the procedure below to change or confirm settings for the Panel setup menu.

1. Confirm that the printer is in one of the following conditions.
 - Receiving data
 - Analyzing data
 - Printing
2. Press the [Menu] key on the operation panel.

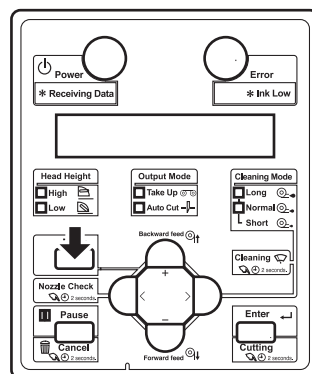

- "Menu5: Temperature" is displayed on the operation panel.
3. Press the [+] key or [-] key to change or confirm settings.

NOTE

- For the setting items whose settings can be changed or confirmed, refer to "[4.4.5.2 Settings that can be changed or confirmed while printing](#)".

4.4.5.2 Settings that can be changed or confirmed while printing

NOTE

- When you change a setting during operation, be sure to select "Backup" to save the setting that you changed.
If the printer returns to Normal without "Backup" being selected, the changed setting is not saved.
- Check the following before using the Job status items
 - The values displayed in the Job status items are rough indications. They do not guarantee the strict accuracy.
 - If the length information is not included in the print data, "0" is displayed for all items.
 - You can check the "remaining print" and "remaining time" in the way described in [☞ 4.4.8 Normal Display while Printing.](#)
 - To check the information about the printed data, refer to the following.

Setup item	Setting	Description	Reference
Temperature	Pre	Checks the current temperature of the pre-heater.	—
	Platen	Checks the current temperature of the platen heater.	
	Dryer	Checks the current temperature of the dryer.	
Pre heater	Off / 30 °C to 50 °C	Changes the temperature of the pre-heater.	☞ 5.1.1.1.5 Pre-heater menu
Platen heater	Off / 30 °C to 50 °C	Changes the temperature of the platen heater.	☞ 5.1.1.1.6 Platen heater menu
Dryer	Off / 30 °C to 50 °C	Changes the temperature of the dryer.	☞ 5.1.1.1.7 Dryer menu
PF Adjust	-5.00% to 0.00 to 5.00%	Change the feed adjustment value.	☞ 5.1.1.1.4 Dist.Adj menu
Backup	—	• [Enter] key: Save the changed setting.	—
Job Status	ToDo Length	• Check the whole length of the data (media feed direction) currently being printed.	—
	Done	• Check the printed length of the data currently being printed.	
	Remain	• For the data currently being printed, check the length of the data that has not been printed.	
	Remain Time	• Displays the time remaining for printing.	
	—	• [Cancel] key: The printer returns to Normal.	—

4.4.6 Pausing printing

It is possible to pause to print during printing.

Follow the procedure below to pause or restart printing.

NOTE

- If the printing is paused, the print quality will not be guaranteed.

1. Check that the printer is in operating.
2. Press the [Pause] key on the operation panel.

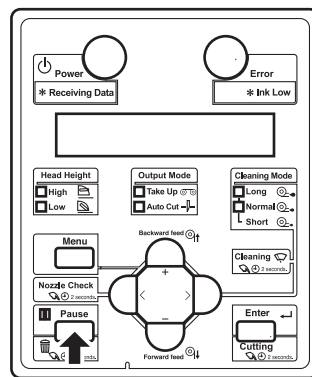

- The printer pauses printing.
 - "PrintRestart -> ENTER" is displayed on the operation panel.
3. To restart printing, press the [Enter] key on the operation panel.

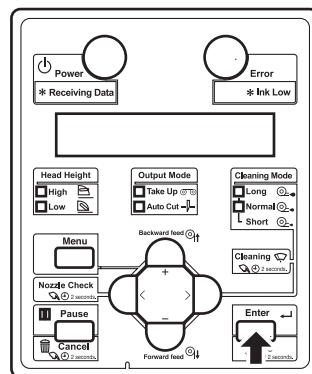

- The printer restarts printing.

4.4.7 Start Printing during Warm up

You can start printing even when the heater temperature has not reached the preset value while the printer is being warmed up.

NOTE

- Even when printing is started during warm up, the printer continues to be warmed up until the preset temperature has been reached.
- When printing is started during warm up, the print quality is not guaranteed.

1. Check if the printer is the printer is being warmed up.
 - "Warming Up" is displayed on the operation panel.
2. Send the data.
 - "Warming Up" "Skip -> E" is displayed on the operation panel.
3. When printing during warm up, press the [Enter] key on the operation panel.

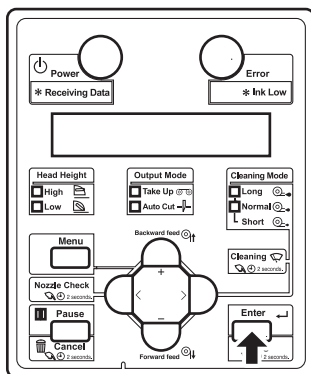

- The printer starts printing.

4.4.8 Normal Display while Printing

The remaining length and remaining time to complete the currently printing data can be displayed by an easy operation.

NOTE

- The values displayed in this function are just standard values, not guarantee the accuracy.
- If the print data includes no length data, all information will be displayed as "0".
- To check more detailed information of currently printing data, please refer to the below.
[☞ 4.4.5.2 Settings that can be changed or confirmed while printing](#)
- To check the information of printed data, please refer to the below.
[☞ 5.8 Job Status Menu](#)

Follow the procedures below to display the information.

1. Check if the printer is printing a data.
2. Press [-] key on the operation panel to display [Print Remain].

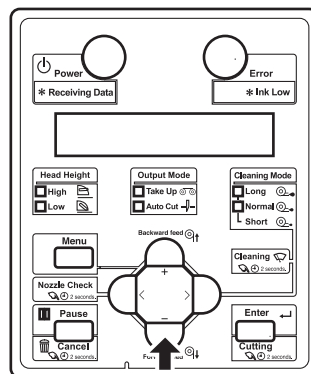

- The remaining length of data currently printing will be displayed.

P r i n t R e m a i n x x x . x m

TIP

- When the length display setting is set to inch, the length will be displayed in inch.
[☞ 5.7.3 Length menu](#)
- The [+] key on the operation panel also can switch the display. In that case, [Remain Time] (Step 3) will be displayed first.

- Press [-] key on the operation panel to display [Remain Time].

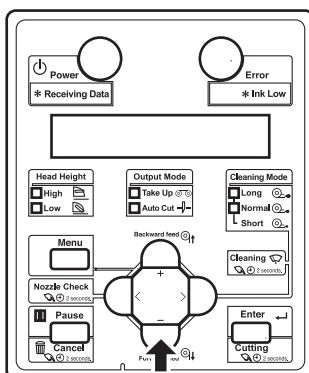

- The remaining length of data currently printing will be displayed.

R e m a i n T i m e x x x x m i n

- To return the display to [Printing], press [-] key on the operation panel.

P r i n t i n g

4.5 Using spectrophotometer (SPECTROVUE VM-10)

The optional spectrophotometer (SPECTROVUE VM-10) can be attached to print and measure the color target. Performing color calibration or profiling of the printer by using RIP software compatible with SPECTROVUE VM-10 enables printing with more accurate colors.

For more information about the option, contact your local MUTOH dealer.

Follow the procedure below.

NOTE

- Do not install the printer in a place that is subject to strong light (sunlight, etc). Getting strong light on the color measurement may affect the measurement accuracy.
- To use SPECTROVUE VM-10, the printer setting must be as follows. Make sure the setting before use.
- Media detection: Top & Width or Width
- Output mode: Off or Auto Cut
↳ [5.1.6 Output Mode menu](#)
- When the color target is printed on the translucent or colored media, or the media with patterned indented surfaces, color measurement may not be accurate.
- For details on spectrophotometer (SPECTROVUE VM-10), refer to its operation manual as well.
- When measuring colors, make sure that the color target is dry. If it is not dry enough, the ink may adhere to the pressurizing rollers of the printer.

1. Connect the printer and computer.
↳ [3.7 Connecting the printer to PC](#)
2. Turn the printer ON.
3. Set the media.
↳ [3.4 Loading media](#)
4. Set the user type setting.
↳ [3.4.3 Setting the User Type Setting](#)
 - When the user type setting and media initial operation are complete, "Ready to Print" is displayed on the operation panel.
5. Start RIP software to print and measure the color target.

NOTE

- For the setting and operations of the RIP software, refer to its operation manual.
- The printer starts printing the color target.

- "Printing" is displayed on the operation panel.
- After printing is complete, "Attaching instrument [ENTER]" is displayed on the operation panel.

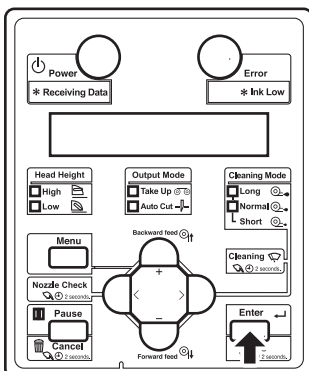

NOTE

- Do not open the covers or move media loading lever during printing.

6. Press the [Enter] key.

- "Open mainte. cover." is displayed on the operation panel.

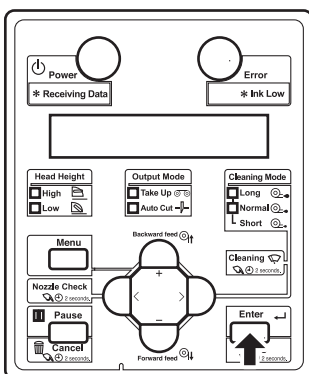

7. Open the maintenance cover.

- "Set white plate then close mainte. cover." is displayed on the operation panel.

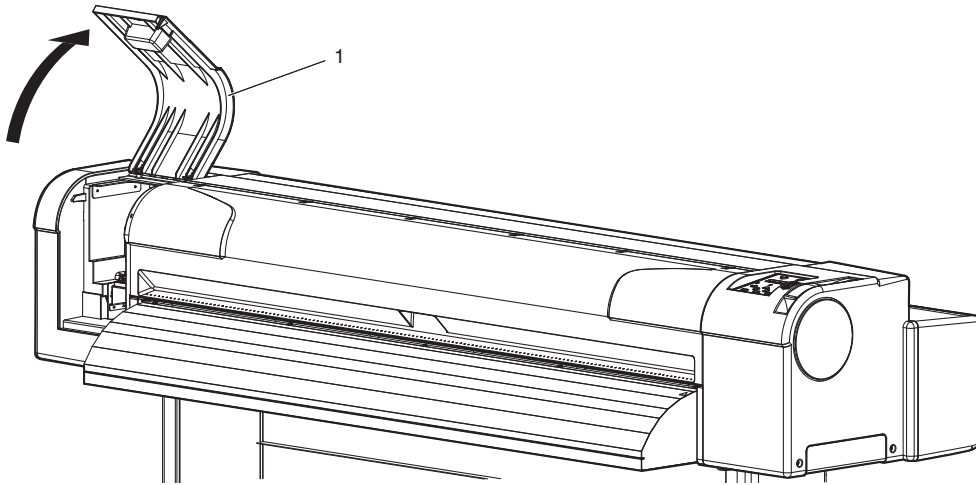

No.	Name
1	Maintenance cover

8. Remove the white reference plate from the plate installation place, turn it over so that the white side faces up, and install it back to the original place.

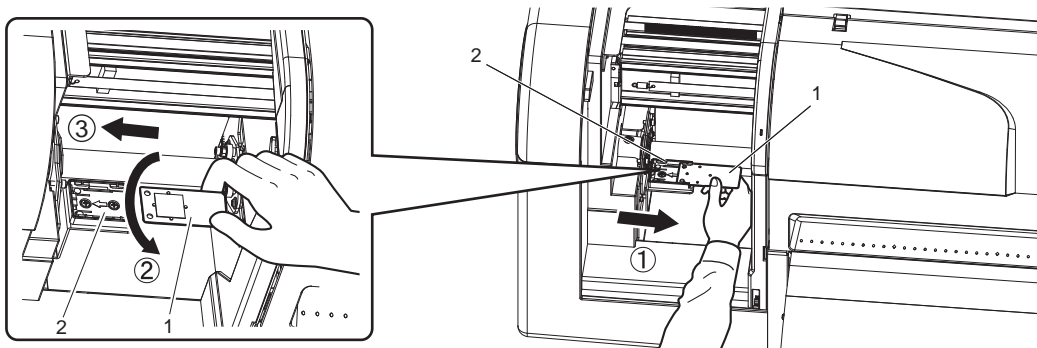

No.	Name
1	White reference plate
2	Plate installation place

NOTE

- Before measuring the color target, make sure that the white side of the white reference plate is facing up.
If the black side is facing up, it will not be measured accurately.

9. Close the maintenance cover.

- "Open front cover." is displayed on the operation panel.

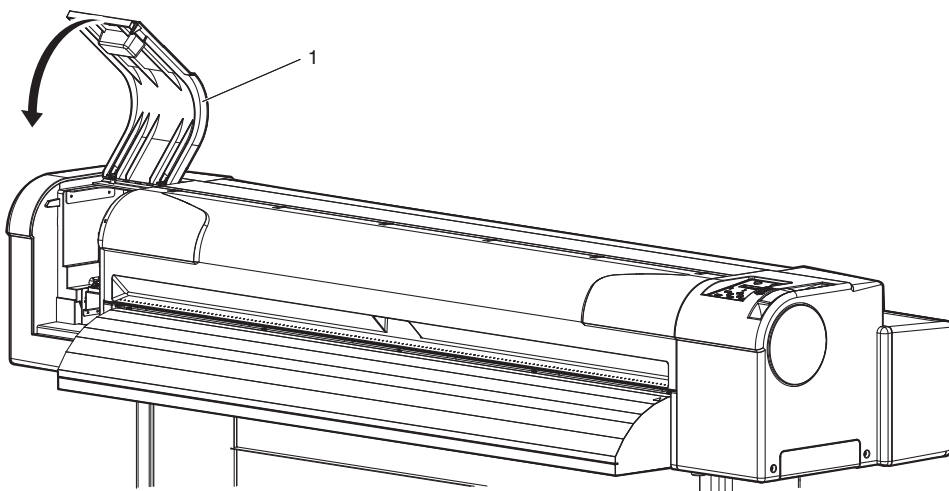

No.	Name
1	Maintenance cover

10. Open the front cover.

- "Remove connector cap and attach instrument [ENTER]" is displayed on the operation panel.

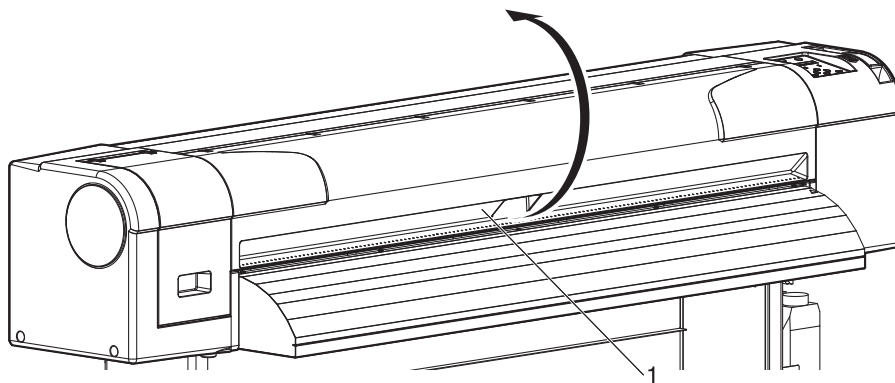

No.	Name
1	Front cover

- Firmly pinch the tabs on both sides of the connector cap with your fingers, pull the connector cap forward to remove it from the print head.

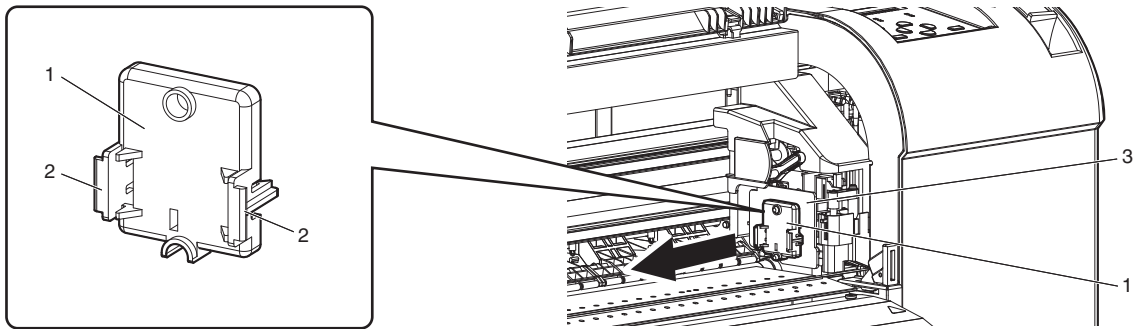

No.	Name
1	Connector cap
2	Tabs
3	Print head section

- Press the release buttons on both sides of spectrophotometer (SPECTROVUE VM-10), install it to the connector at the print head.

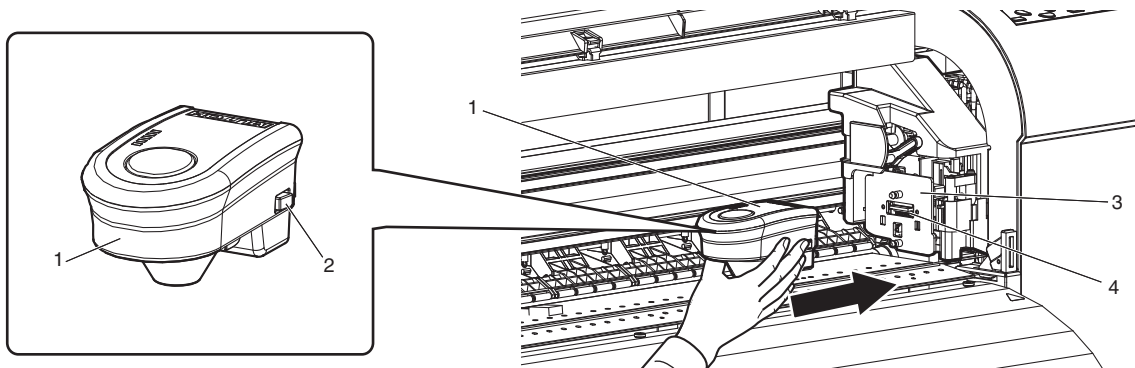

No.	Name
1	Spectrophotometer
2	Release buttons
3	Print head section
4	Connector

NOTE

- Make sure that spectrophotometer is NOT installed at an angle, and that there is no gap between the connector and spectrophotometer.

13. Press the [Enter] key.

- The printer checks the connection between the printer and spectrophotometer.
- "Close front cover" is displayed on the operation panel.

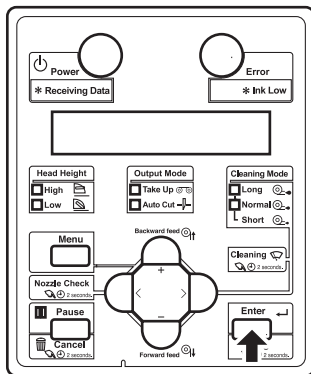

14. Close the front cover.

- "Wait for a while..." is displayed on the operation panel.
- The printer starts white calibration.

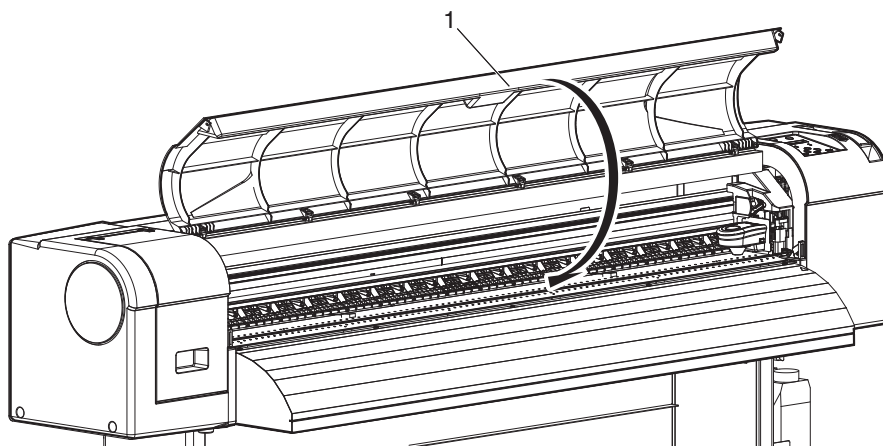

No.	Name
1	Front cover

15. When "Start measurement [ENTER]" is displayed on the operation panel, press the [Enter] key.

- Spectrophotometer starts measuring the color target.
- "Measuring..." is displayed on the operation panel.
- After measuring is complete, "Detaching instrument [ENTER]" is displayed on the operation panel.

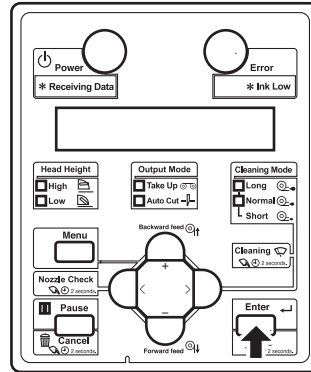

NOTE

- Color measurement starts either automatically or manually, depending on the RIP software feature. The steps above are for manual measurement.
- When the measurement starts automatically, "Ink Drying xxxxxx" (xxxxx is a number) may be displayed on the operation panel.
- Do not open the covers or move media loading lever during measuring.

16. Press the [Enter] key.

- "Open front cover" is displayed on the operation panel.

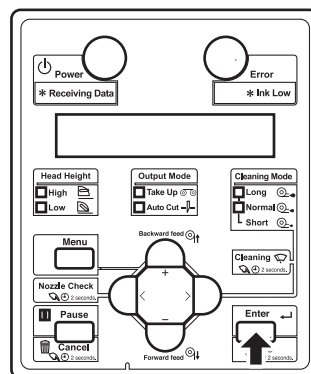

17. Open the front cover.

- "Detach instrument and Set connector [ENTER]" is displayed on the operation panel.

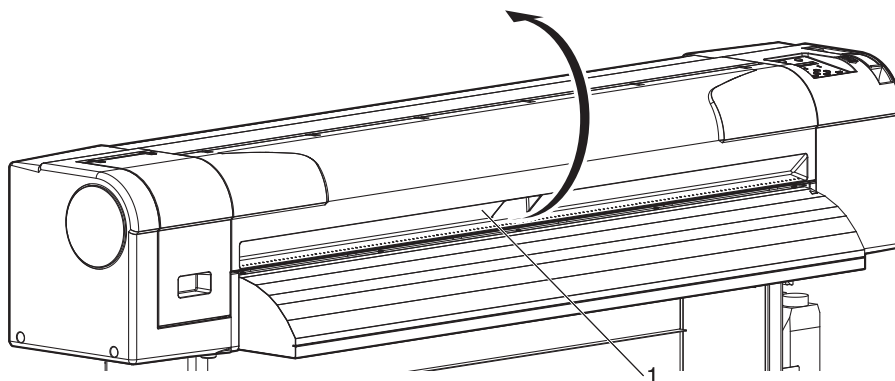

No.	Name
1	Front cover

18. While pressing the release buttons on both sides of spectrophotometer, pull it forward to remove it from the print head.

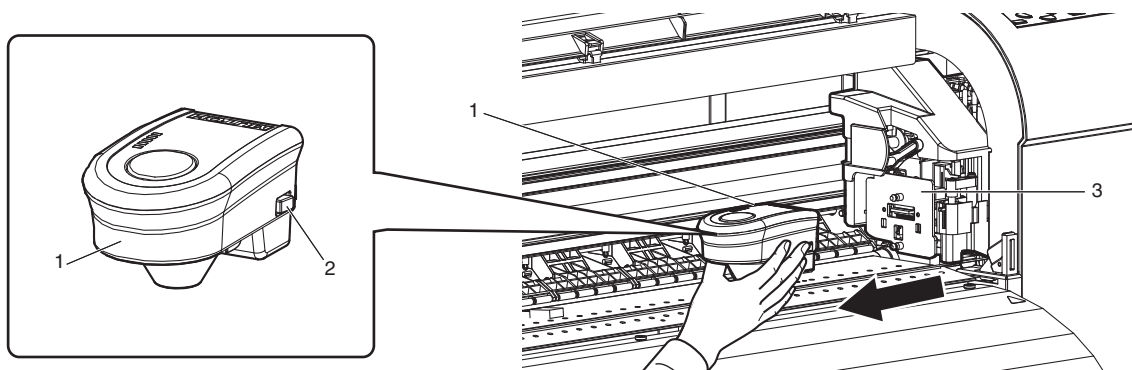

No.	Name
1	Spectrophotometer
2	Release buttons
3	Print head section

19. Firmly pinch the tabs on both sides of the connector cap with your fingers, and install it to the connector at the print head.

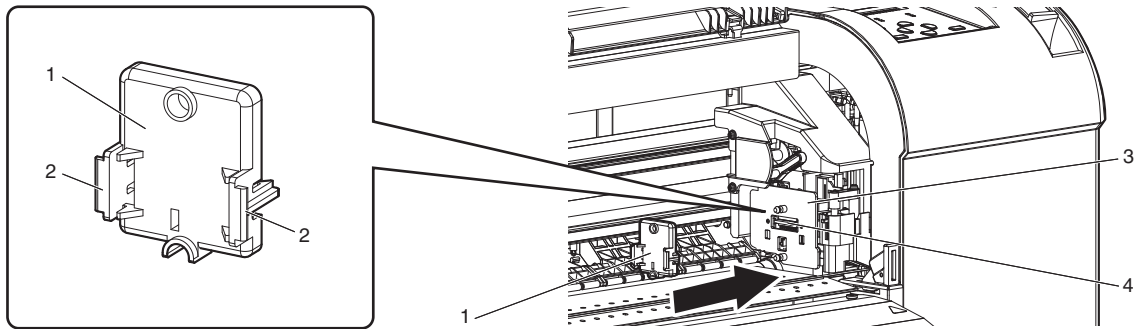

No.	Name
1	Connector cap
2	Tabs
3	Print head section
4	Connector

20. Press the [Enter] key.

- "Wait for a while..." is displayed on the operation panel.
- Make sure that the connector cap is installed on the printer.
- "Close front cover" is displayed on the operation panel.

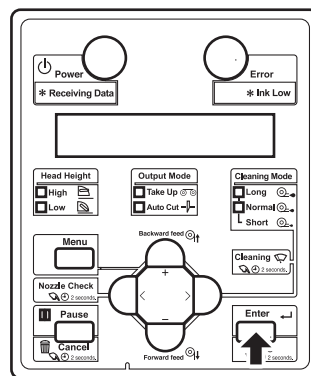

21. Close the front cover.

- "Open mainte. cover." is displayed on the operation panel.

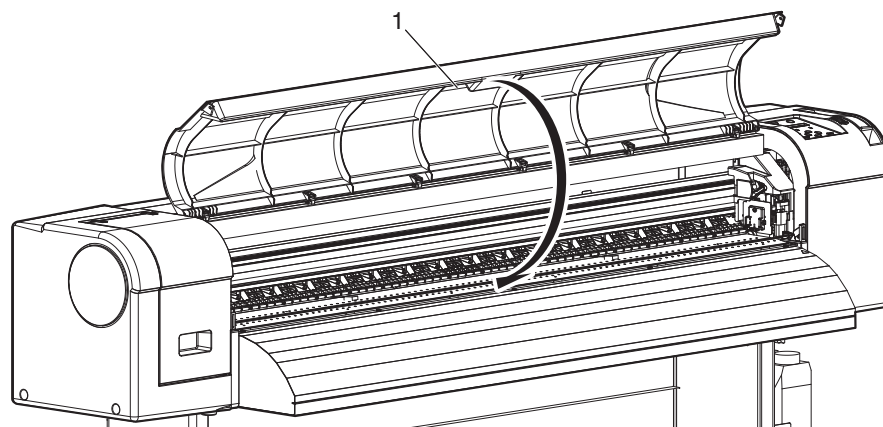

No.	Name
1	Front cover

22. Open the maintenance cover.

- "Remove white plate then close mainte. cover." is displayed on the operation panel.

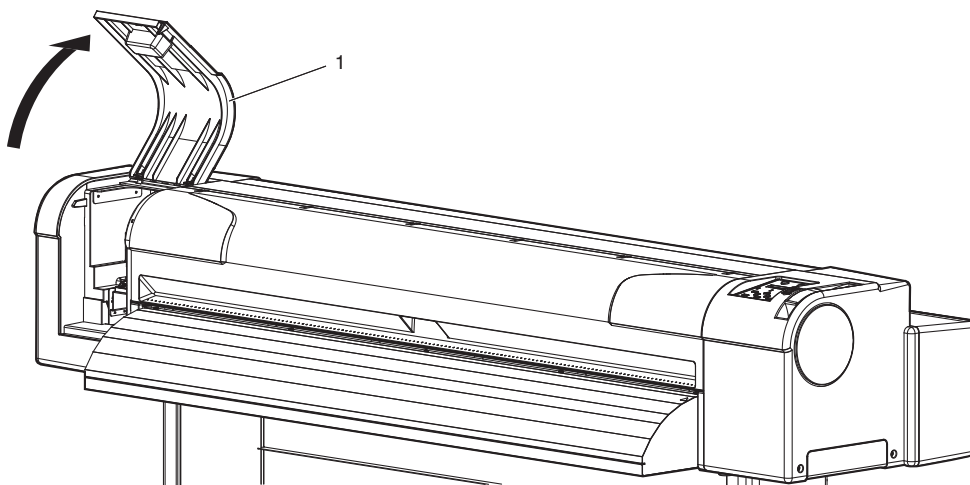

No.	Name
1	Maintenance cover

23. Remove the white reference plate from the plate installation place, turn it over so that the black side faces up, and install it back to the original place.

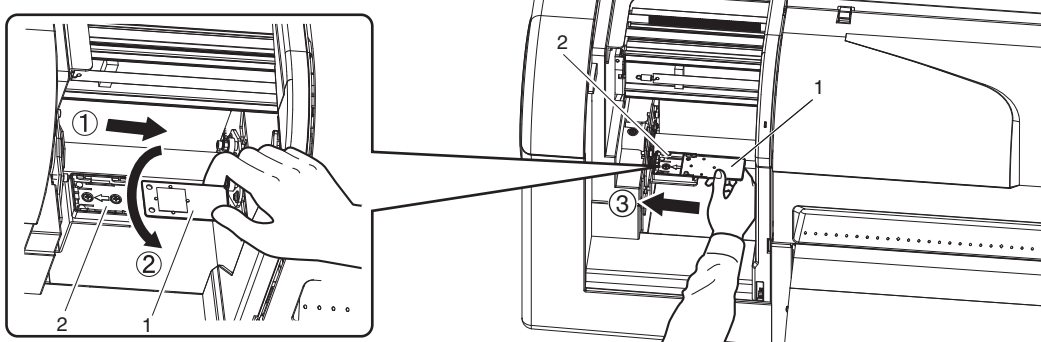

No.	Name
1	White reference plate
2	Plate installation place

NOTE

- When the white reference plate is not in use, make sure that it is turned over facing down to avoid any contamination.

24. Close the maintenance cover.

- "Ready to Print" is displayed on the operation panel.
- For the subsequent operations, follow the instructions of the RIP software.

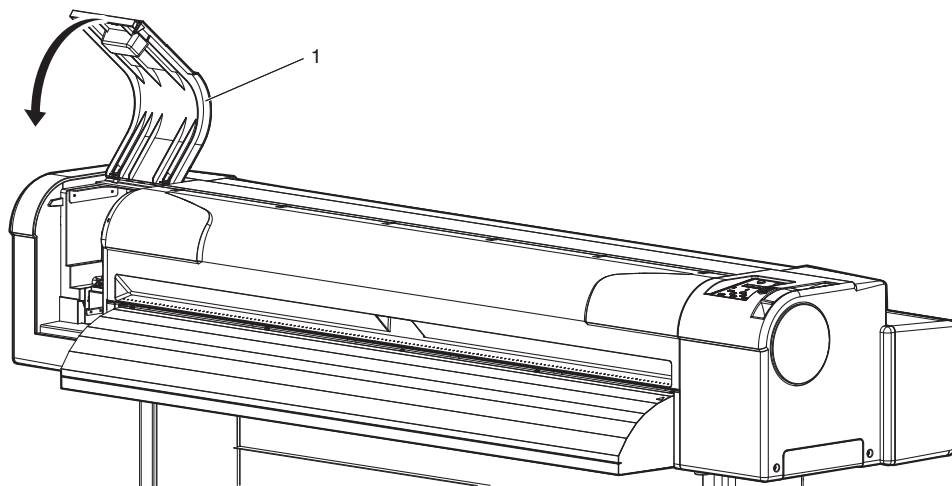

No.	Name
1	Maintenance cover

5 Panel setup menu

The section explains the Setup menu of the printer.

Setup item	Description
Setup menu	Various settings of the printer are configured. ☞ 5.1 Setup menu
Test Print menu	Performs nozzle check of the print head and setup list. ☞ 5.2 Test Print Menu
Cleaning menu	Performs head cleaning. ☞ 5.3 Cleaning menu
Menu Option menu	Sets up the contents of the Setup menu. ☞ 5.4 Menu Option menu
Version menu	Displays the versions of the firmware. ☞ 5.5 Version menu
Sleep Mode menu	Sleep mode settings are configured. ☞ 5.6 Sleep Mode menu
Display	Sets the language and unit displayed on the LCD monitor of the operation panel. ☞ 5.7 Display menu
Job Status menu	Displays information about the previous printing result of the Job status. ☞ 5.8 Job Status Menu













TIP

The <> parts in each list are factory default settings (default).

5.1 Setup menu



Various settings of the printer are configured.

Setup item	Description
User Type	Sets the user type setting for printing. <ul style="list-style-type: none"> [Enter] key: shifts to the sub menu.  5.1.1 User Type menu
Spitting	Sets up the spitting operation while printing. <ul style="list-style-type: none"> [Enter] key: shifts to the sub menu.  5.1.2 Spitting menu
Side Margin	Specifies the right and left margins of printed media. <ul style="list-style-type: none"> [Enter] key: shifts to the sub menu.  5.1.3 Side Margin menu
Media Initial	Sets whether to detect the media width and edge while initializing the media. <ul style="list-style-type: none"> [Enter] key: shifts to the sub menu.  5.1.4 Media Initial menu
Media Width	Specifies the media width between the loading mark and the left end if media detection is not performed during media initialization. Displays the detected media width if media detection is performed during media initialization. <ul style="list-style-type: none"> [Enter] key: shifts to the sub menu.  5.1.5 Media Width menu
Output mode	Sets the media ejection method after printing. <ul style="list-style-type: none"> [Enter] key: shifts to the sub menu.  5.1.6 Output Mode menu
Method of Cut	Sets the media cutting method after printing. <ul style="list-style-type: none"> [Enter] key: shifts to the sub menu.  5.1.7 Method of Cut menu
Origin	Sets the beginning of printing (origin) of the print data. <ul style="list-style-type: none"> [Enter] key: shifts to the sub menu.  5.1.8 Origin menu
Prev. Stick	Sets up to prevent media from sticking when printing starts. <ul style="list-style-type: none"> [Enter] key: shifts to the sub menu.  5.1.9 Prev. Stick menu
StandbyHeating	Sets the time to preheat the heater while the printer is n standby mode. <ul style="list-style-type: none"> [Enter] key: shifts to the sub menu.  5.1.10 StandbyHeating menu
Head Travel	Sets up the range that the print head moves while printing. <ul style="list-style-type: none"> [Enter] key: shifts to the sub menu.  5.1.11 Head Travel menu
Multi Strike	Sets up the overwrite count per line. <ul style="list-style-type: none"> [Enter] key: shifts to the sub menu.  5.1.12 Multi Strike menu
Strike Wait	Sets up the waiting time while overwrite printing. <ul style="list-style-type: none"> [Enter] key: shifts to the sub menu.  5.1.13 Strike Wait menu

Setup item	Description
Slant Check	Sets up slanting detection during media loading. <ul style="list-style-type: none"> • [Enter] key: shifts to the sub menu.  5.1.14 Slant Check menu
Auto Cleaning	Sets up the time for auto cleaning during standby, before printing, and during printing. <ul style="list-style-type: none"> • [Enter] key: shifts to the sub menu.  5.1.15 Auto Cleaning menu
Ink Status	Displays the various information (ink status) about ink cartridges that are installed in the slots and information about Smart/C. <ul style="list-style-type: none"> • [Enter] key: shifts to the sub menu.  5.1.16 Ink Status menu
Roll Length	Sets up the roll media length. <ul style="list-style-type: none"> • [Enter] key: shifts to the sub menu.  5.1.17 Roll Length menu
Longstore	Wash the print head with the cleaning fluid. <ul style="list-style-type: none"> • [Enter] key: shifts to the sub menu.  5.1.18 Longstore menu
CR Maintenance	Performs maintenance. <ul style="list-style-type: none"> • [Enter] key: shifts to the sub menu.  5.1.19 CR Maintenance menu
Initialization	Returns the settings of the printer to default. <ul style="list-style-type: none"> • [Enter] key: shifts to the sub menu.  5.1.20 Initialization menu
Life Times	Displays the operational life time of each part. <ul style="list-style-type: none"> • [Enter] key: shifts to the sub menu.  5.1.21 Life Times menu
IP Address	Sets the IP address of the printer. <ul style="list-style-type: none"> • [Enter] key: shifts to the sub menu.  5.1.22 IP Address menu
Subnet Mask	Sets the subnet mask of the printer. <ul style="list-style-type: none"> • [Enter] key: shifts to the sub menu.  5.1.23 Subnet Mask menu
Gateway	Sets the gateway. <ul style="list-style-type: none"> • [Enter] key: shifts to the sub menu.  5.1.24 Gateway menu
Temporary	Displays the settings of "Off" or "ALL Off" in the Selection menu in the Setup menu temporarily. <ul style="list-style-type: none"> • [Enter] key: returns to the previous menu with all set up items displayed. • [Cancel] key: returns to the previous status in the Selection menu when the Setup menu is displayed.  5.4 Menu Option menu
—	<ul style="list-style-type: none"> • [Cancel] key: shifts to the previous menu.  5 Panel setup menu

5.1.1 User Type menu

Sets the user type setting for printing.

Setup item	Setting	Description
User Type	Type 1	Settings for the media type to print are configured. It is possible to set 30 different user settings as "Type 1 to 30" for printing. • [Enter] key: shifts to the sub menu.  5.1.1.1 User Type menu
	Type 2	
	...	
	Type 29	
	Type 30	
	—	• [Cancel] key: saves the setting and shifts to the previous menu.  5.1 Setup menu

5.1.1.1 User Type menu

Various settings on the user type settings are configured.

In the user type menu, 30 different settings can be set as Type 1 to 30 for the following printing operation.

NOTE

- If media other than recommended one (user type) is used, the following problems may occur.
- Media detection error
- Slant, torn, and wrinkle of media
- Media jams
- Favorable print quality cannot be obtained due to blots, blurs or dirt of ink.
- End detection of roll media cannot be performed, etc.

The problems caused by the use of the media other than recommended one will not be covered by the warranty and repair expenses will be paid by the customer.

For details, contact your local MUTOH dealer.

Setup item	Setting	Description
Type 1 to 30	PrintMode	Sets up the Print Mode according to the usage of print data or print speed. • [Enter] key: shifts to the sub menu. ☞ 5.1.1.1.1 Print Mode menu
	Effect	Sets up the Effect menu. • [Enter] key: shifts to the sub menu. ☞ 5.1.1.1.2 Effect menu
	Adjust Print	Sets up when adjusting the printer for the optimum quality of image print. • [Enter] key: shifts to the sub menu. ☞ 5.1.1.1.3 Adjust Print menu
	PF Adjust	Sets up various settings on the media feed compensation. • [>] key: shifts to the sub menu. ☞ 5.1.1.1.4 Dist.Adj menu
	Pre heater	Sets the temperature of the pre-heater. • [Enter] key: shifts to the sub menu. ☞ 5.1.1.1.5 Pre-heater menu
	Platen heater	Sets the temperature of the platen heater. • [Enter] key: shifts to the sub menu. ☞ 5.1.1.1.6 Platen heater menu
	Dryer	Sets the temperature of the dryer. • [Enter] key: shifts to the sub menu. ☞ 5.1.1.1.7 Dryer menu
	Vacuum Fan	Sets up vacuum fan operation. • [Enter] key: shifts to the sub menu. ☞ 5.1.1.1.8 Vacuum Fan menu
	—	• [Cancel] key: shifts to the previous menu. ☞ 5.1.1 User Type menu

5.1.1.1.1 Print Mode menu

Settings for print quality (Print Mode) are set according to the usage of print data or print speed.

Setup item	Setting	Description
Mode	Quality 1	Set the print mode. <ul style="list-style-type: none"> Quality 1 to 4: Suitable for printing photographs. Set this when high quality print is required. Graphics 1 to 2: Suitable for printing photographs. Set this when standard print quality is required. Graphics 3 to 4: Suitable for printing illustrations. Set this when standard print quality is required. Banner 1 to 4: Suitable for printing outdoor signs or test printing. Set this when fast printing is required. While pressing the [>] key, the details of each print mode is displayed.  Details of Print Mode
	Quality 2	
	Quality 3	
	Quality 4	
	Graphics 1	
	<Graphics 2>	
	Graphics 3	
	Graphics 4	
	Banner 1	
	Banner 2	
	Banner 3	
	Banner 4	
	—	

NOTE

The colors of the image may become irregular depending on the media and print mode you are using. In such a case, use the following mode to improve irregular colors.

- When using the print mode for bidirectional printing (refer to the following chart " [Details of Print Mode](#)"), switch to the print mode for unidirectional printing.
- When using Graphics 1 to 2, change it to Quality 1 to 4.

Details of Print Mode

The set values of print quality that are registered in each print mode are as follows.

NOTE

In the following chart, the print speed becomes faster as it matches the chart.

- The number of paths is fewer
- The resolution is lower
- The printing direction is bidirectional

The print speed may be affected depending on the selected effect.

 [5.1.1.1.2 Effect menu](#)

PrintMode	Resolution	Pass	Direction
Quality 1	1440 x 1440dpi	16 times	Uni (unidirectional)
Quality 2	1440 x 1440dpi	16 times	Bi (bidirectional)
Quality 3	720 x 1440dpi	8 times	Uni (unidirectional)
Quality 4	720 x 1440dpi	8 times	Bi (bidirectional)
Graphics 1	720 x 720dpi	8 times	Uni (unidirectional)
Graphics 2	720 x 720dpi	8 times	Bi (bidirectional)
Graphics 3	720 x 720dpi (L)	8 times	Uni (unidirectional)
Graphics 4	720 x 720dpi (L)	8 times	Bi (bidirectional)
Banner 1	720 x 720dpi	4 times	Uni (unidirectional)
Banner 2	720 x 720dpi	4 times	Bi (bidirectional)
Banner 3	360 x 720dpi	2 times	Uni (unidirectional)
Banner 4	360 x 720dpi	2 times	Bi (bidirectional)

5.1.1.1.2 Effect menu

Sets up the Effect menu.

Set up this menu when you want to improve print quality by adjusting the set Print Mode.

NOTE

- The print quality may not be improved depending on the printing condition.

Setup item	Setting	Description
Effect	<None> *1	The Effect function is not used.
	Wave	The printing joint will be the wave form. The print quality may be improved than None.
	<Fog> *1	The printing joint will shade off. Set up this menu when obvious white lines or uneven print density appear on printed media in "Wave". Mode for low resolution (360 x 720dpi).
	<Fine & Fuzz> *1	The printing joint will shade off as the wave form. Perform the printing at slower speed than "Wave".
	<Fine & Fog> *1	The printing joint will shade off. Set up this menu to improve horizontal banding with Fine & Fuzz. Perform the printing at a slower speed than Fine & Fuzz.
	A-S.Fine & Wave	Performs "Wave" printing using the half of the print head nozzles. Since only half of the print head nozzles are used, printing speed becomes a half of "Wave". Set up this menu to improve the print quality compared with "Fine & Fuzz". If used when one side of the nozzles are clogged, quality deterioration may be avoided.
	B-S.Fine & Wave	Performs "Wave" printing using the half of the print head nozzles on the opposite side of "A-S.Fine & Wave". Since only half of the print head nozzles are used, printing speed becomes a half of Wave. Set up this menu to improve the print quality compared with "Fine & Fuzz". If used when one side of the nozzles are clogged, quality deterioration may be avoided.
	—	<ul style="list-style-type: none"> [Enter] key: saves the setting and shifts to the previous menu. [Cancel] key: cancels the setting and shifts to the previous menu.  5.1 Setup menu

*1 The default value of the effect differs depending on the selected print mode as shown below.

Print Mode	Effect Default Value
Quality1 to 4	Fine&Fuzz
Graphics1 to 2	Fine&Fuzz
Graphics3 to 4	Fine&Fog
Banner1 to 2	Fog
Banner3 to 4	None

5.1.1.1.3 Adjust Print menu

Sets up when adjusting the printer for the optimum quality of image print.

This setting is different for each user type setting.





NOTE

- This printer was adjusted at the factory shipment so that it obtains the optimum printing quality. Adjust the quality if the print quality changes after the installation environment or the media is changed.
- After performing Standard adjust print and changing the user type setting, make sure to perform Adjust print.
- When performing Custom adjust print, the print modes are adjusted all at once. Therefore, you do not need to perform print adjustment even when the user type setting has been newly set or changed.
- When using RIP software, etc, and setting the resolution which is different from the setting in the user type setting, make sure to perform adjustment for all print modes by Custom Adjust Print.

Setup item	Setting	Description
Confirmation pattern	Standard	Adjusts the print mode in the user type setting which is currently set only. ☞ Standard Adjust Print Menu
	Custom	Adjusts all print modes. ☞ Custom Adjust Print Menu
	—	[Cancel] key: cancels the setting and shifts to the previous menu. ☞ 5.1.1.1 User Type menu

Standard Adjust Print Menu





Adjusts only the print mode in the user type setting which is currently set.

Setup item	Setting	Description
Standard	Standard Confirmation Pattern	Print the test pattern for the alignment. Check before adjusting.  3.6.1.1 Standard Confirmation Pattern
	Standard Rough Adjustment Pattern	Perform this adjustment when the misalignment is big. Print adjustment patterns and enter the set values.  3.6.1.2 Standard Rough Adjustment Pattern
	Standard Micro Adjustment Pattern	Perform this adjustment when the misalignment is small. Print adjustment patterns and enter the set values.  3.6.1.3 Standard Micro Adjustment Pattern
	—	<ul style="list-style-type: none"> [Cancel] key: cancels the setting and shifts to the previous menu.  5.1.1.1.3 Adjust Print menu

Custom Adjust Print Menu







All patterns from A to F can be adjusted.

By performing this adjustment, all print modes will be adjusted.

Setup item	Setting	Description
Custom	Custom Confirmation Pattern	Print the confirmation patterns A to F for print adjustment. Check before adjusting.  3.6.2.1 Custom Confirmation Pattern
	Custom Rough Adjustment Pattern	Perform this adjustment when the misalignment is big. Print the confirmation patterns A to F and enter the set value.  3.6.2.2 Custom Rough Adjustment Pattern
	Adjust Pattern ALL	Perform this adjustment when the misalignment is small. Print the confirmation patterns A to F and enter the set value.  3.6.2.3.1 Adj. PatternALL
	Adjust Pattern A	When the misalignment is small, select and print one of the adjust patterns A to F and register the set value.  3.6.2.3.2 Each Adjust Patterns
	Adjust Pattern B	
	Adjust Pattern C	
	Adjust Pattern D	
	Adjust Pattern E	
Adjust Pattern F		
—	<ul style="list-style-type: none"> [Cancel] key: cancels the setting and shifts to the previous menu.  5.1.1.1.3 Adjust Print menu	

5.1.1.1.4 Dist.Adj menu

Sets up various settings on the media feed compensation.

Setup item	Setting	Description
PF	Initial Print	Performs initial adjustment printing. • [Enter] key: shifts to the sub menu.  (1) Initial Print menu
	Init.Adj.Change	Sets up Initial Adjust Change. • [Enter] key: shifts to the sub menu.  (2) Init.Adj.Change menu
	Confirm Print	Performs Confirm Print. • [Enter] key: shifts to the sub menu.  (3) Confirm Print menu
	Micro Print	Performs Micro Adjustment Print. • [Enter] key: shifts to the sub menu.  (4) Micro Print menu
	Micro Adj.Change	Sets up Micro Adjustment Change. • [Enter] key: shifts to the sub menu.  (5) Micro Adj.Change menu
	—	• [Cancel] key: shifts to the previous menu.  5.1.1.1 User Type menu

(1) Initial Print menu

Performs Initial Adjust Print.

Setup item	Setting	Description
FeedLength	100mm to <250mm> to 500mm	Changes the length (feed length) of the media feed direction for Initial Print. • [Enter] key: Determines the setting. "Printing" is displayed on the operation panel and Initial Print starts. After printing, the printer enters Normal.
	—	• [Cancel] key: cancels the setting and shifts to the previous menu.  5.1.1.1.4 Dist.Adj menu

(2) Init.Adj.Change menu

Sets up Initial Adjust Change.

Setup item	Setting	Description
Init.	The set value ± 50.0 mm in "Feed length" of Initial adjust print	Sets up Initial Adjust Change. e.g) When the set value in "Feed length*" of Initial adjust print is set to 250mm, the adjustment range in this menu is 200mm to 300mm.
	—	<ul style="list-style-type: none"> • [Enter] key: saves the setting and shifts to the previous menu. • [Cancel] key: cancels the setting and shifts to the previous menu.  5.1.1.1.4 Dist.Adj menu

(3) Confirm Print menu

Performs Confirm Print.

Setup item	Setting	Description
FeedLength	100mm to <250mm> to 500mm	Changes the length (feed length) of the media feed direction for Confirm Print. <ul style="list-style-type: none"> • [Enter] key: Determines the setting. "Printing" is displayed on the operation panel and Initial Print starts. After printing, the printer enters Normal.
	—	<ul style="list-style-type: none"> • [Cancel] key: cancels the setting and shifts to the previous menu.  5.1.1.1.4 Dist.Adj menu

(4) Micro Print menu

Performs Micro Adjustment Print.

Setup item	Setting	Description
Micro Print	Printing	Prints the following PF pattern (micro adjustment) with a focus on the micro adjustment value. •0%, $\pm 0.05\%$, $\pm 0.1\%$, $\pm 0.2\%$
	—	<ul style="list-style-type: none"> • [Cancel] key: shifts to the previous menu. Stops printing and returns to the previous menu if printing is in progress.  5.1 Setup menu

(5) Micro Adj.Change menu

Sets up Micro Adjustment Change.

Setup item	Setting	Description
Micro Adj.Change	-5.00% to <0.00> to 5.00%	Sets up Micro Adjustment Change.
	—	<ul style="list-style-type: none"> • [Enter] key: saves the setting and shifts to the previous menu. • [Cancel] key: cancels the setting and shifts to the previous menu. 🔗 5.1 Setup menu

5.1.1.1.5 Pre-heater menu

Sets the temperature of the pre-heater.

Set to curb a rapid temperature change at the printing portion by pre-heating the media before printing.

NOTE

- The set temperature of the pre-heater differs depending on the media.
For the set temperatures of the pre-heater, refer to "recommended media list".

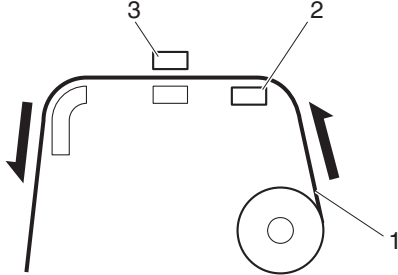
Setup item	Setting	Description
Pre heater	Off / <30 °C> to 50 °C	Sets the temperature of the pre-heater.  1.Roll media 2.Pre heater 3.Print head
	—	<ul style="list-style-type: none"> • [Enter] key: saves the setting and shifts to the previous menu. • [Cancel] key: cancels the setting and shifts to the previous menu. 🔗 5.1.1.1 User Type menu



5.1.1.1.6 Platen heater menu

Sets the temperature of the platen heater.

Set to improve print quality by allowing the ink to settle by heat.

NOTE

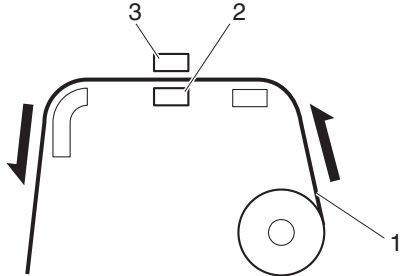
- The set temperature of the platen heater differs depending on the media.
For the set temperatures of the platen heater, refer to "recommended media list".



Setup item	Setting	Description
Platen heater	Off / <30 °C> to 50 °C	<p>Sets the temperature of the platen heater.</p>  <p>1.Roll media 2.Platen heater 3.Print head</p>
	—	<ul style="list-style-type: none"> [Enter] key: saves the setting and shifts to the previous menu. [Cancel] key: cancels the setting and shifts to the previous menu. <p> 5.1.1.1 User Type menu</p>

5.1.1.1.7 Dryer menu

Sets the temperature of the dryer.
Set to dry the print side after printing.

NOTE

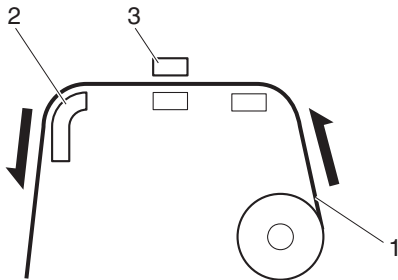
- The set temperature of the dryer differs depending on the media.

Setup item	Setting	Description
Dryer	Off / <30 °C> to 50 °C	<p>Sets the temperature of the dryer.</p>  <p>1.Roll media 2.Dryer 3.Print head</p>
	—	<ul style="list-style-type: none"> [Enter] key: saves the setting and shifts to the previous menu. [Cancel] key: cancels the setting and shifts to the previous menu. <p> 5.1.1.1 User Type menu</p>

5.1.1.1.8 Vacuum Fan menu

Sets up vacuum fan operation.

Setup item	Setting	Description
Vacuum Fan	Low	Set when there is a possibility of a paper jam caused by failure in media loading when the setting is Middle.
	Middle	Set this when there is a possibility that media feeding may fail and paper may be jammed with the High setting.
	<High>	Set when using general media.
	—	<ul style="list-style-type: none"> [Enter] key: saves the setting and shifts to the previous menu. [Cancel] key: cancels the setting and shifts to the previous menu. <p> 5.1.1.1 User Type menu</p>

5.1.2 Spitting menu

Sets up the spitting operation while printing.

NOTE

- When Spitting is set to "Off", the nozzle will become easily clogged because spitting is not performed. In this instance, print quality cannot be guaranteed.
- When the spitting setting is "On Media", the maximum printable media width becomes 10mm shorter.
Therefore, the side margins become "value set on side margin menu" +5mm.
- Depending on the setting, the right margin is a sum of the following.
"Y (print head transferring distance) of the Origin menu" + "5mm (when the spitting setting is "On Media")" + "value set on side margin menu"

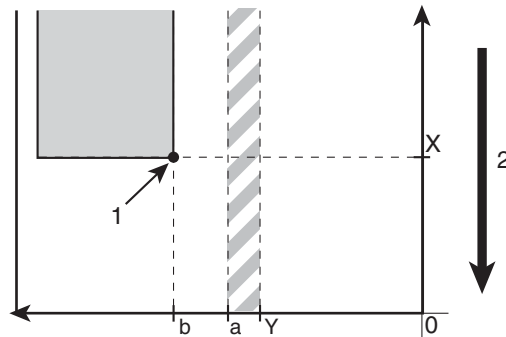

1. Starting position
2. Media feed direction

X (media feeding distance)

Y (print head transferring distance)

a (0mm/5mm: The spitting setting is On, Off/On Media)

b (5mm to 25mm: Side margin setting amount)

🔗 [5.1.3 Side Margin menu](#)

🔗 [5.1.8 Origin menu](#)

Setup item	Setting	Description
Spitting	<On>	Perform the flushing operation on the spitting box located on the origin side for every shuttle. •[Enter] key: saves the setting and shifts to the sub menu. ☞ 5.1 Setup menu
	On Media	Perform the spitting operation on the page margins. The printing speed will be improved since the number of time to return to the spitting box is reduced. •[Enter] key: saves the setting and shifts to the sub menu. ☞ 5.1.2.1 Spitting Pass count menu
	Off	Spitting operation is not performed. •[Enter] key: saves the setting and shifts to the previous menu. ☞ 5.1 Setup menu
	—	•[Cancel] key: cancels the setting and shifts to the previous menu. ☞ 5.1 Setup menu

5.1.2.1 Spitting Pass count menu

Set the frequency (spitting return count) that the print head returns to the spitting box (located) on the origin side when setting "On" or "On Media" in the Spitting menu.

NOTE

- If you set the flushing return count to a high number, the nozzle will become easily clogged when printing for a long time because flushing is not performed over the flushing box.

Setup item	Setting	Description
ReturnCount	<1 time> to 999 times	Set the spitting return count.
	—	• [Enter] key: saves the setting and shifts to the previous menu. • [Cancel] key: cancels the setting and shifts to the previous menu. ☞ 5.1.2 Spitting menu

<Example of spitting operation>

Spitting setting	Return Count setting	Operation
On	1 time	Performs the spitting operation on the flushing box on the origin side every time the print head returns to the origin position. Spitting is not performed over the media.
On	5 times	Performs the spitting operation on the spitting box on the origin side every five times the print head returns to the origin position. Spitting is not performed over the media.
On Media	1 time	Performs the spitting operation on the flushing box on the origin side every time the print head returns to the origin position. Flushing is performed over the media every time the print head shuttles back and forth.
On Media	5 times	Performs the spitting operation on the spitting box on the origin side every five times the print head returns to the origin position. Flushing is performed over the media every time the print head shuttles back and forth.
Off	—	Spitting is not performed on the spitting box or the media.

5.1.3 Side Margin menu

Set up the right and left margins (side margins) while printing.

NOTE

- When the spitting menu is set to "On Media", the maximum printable media width becomes 10mm shorter.

Therefore, the side margin becomes "value set on side margin menu" +5mm.

[☞ 5.1.2 Spitting menu](#)

- Depending on the setting, the right margin is a sum of the following.
 "Y (print head transferring distance) of the Origin menu" + "5mm (when the spitting setting is "On Media")" + "value set on side margin menu"

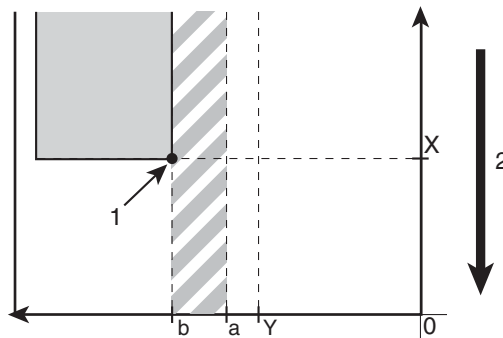

1. Starting position
2. Media feed direction

X (media feeding distance)

Y (print head transferring distance)

a (0mm/5mm: The spitting setting is On, Off/On Media)

b (5mm to 25mm: Side margin setting amount)

[☞ 5.1.2 Spitting menu](#)

[☞ 5.1.8 Origin menu](#)

Setup item	Setting	Description
Side Margin	<5mm> to 25mm	Set the side margins.
	—	<ul style="list-style-type: none"> • [Enter] key: saves the setting and shifts to the previous menu. • [Cancel] key: cancels the setting and shifts to the previous menu. ☞ 5.1 Setup menu

5.1.4 Media Initial menu

Sets whether to detect the media width and edge while initializing the media.

NOTE

- Set the media width that is set in the Media Width menu when setting "Off" in the Media detection menu.
 5.1.5 Media Width menu
- When the Media detection menu is set to "Off", the media cannot be cut automatically.

Setup item	Setting	Description
Init.	Off	The media is not detected.
	Top & Width	Detect the media width and edge while initializing the media.
	<Width>	Detect the media width while initializing the media.
	—	<ul style="list-style-type: none"> • [Enter] key: saves the setting and shifts to the previous menu. • [Cancel] key: cancels the setting and shifts to the previous menu.  5.1 Setup menu

5.1.5 Media Width menu

Specifies the media width between 7mm away from the right edge of the platen and the left end if media detection is not performed during media initialization.

 [\(1\) Media Width menu](#)

Displays the detected media width if media detection is performed during media initialization.

 [\(2\) MediaWidth menu](#)

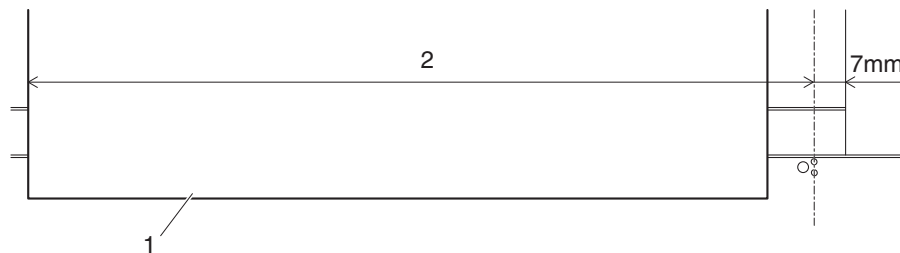

No.	Name
1	Roll media
2	Media width (when not detected)

NOTE

- If the media is loaded as shown in the illustration and media detection is not performed, the printing may be performed between the right edge of the platen and the media.

 [5.1.8 Origin menu](#)

(1) Media Width menu

NOTE

- Setting a larger value than the media width set in the Media Width menu may cause ink to leak on the media or printer.

Setup item	Setting	Description
Media Width	210mm to <1000mm> to 1371mm	Set the media width.
	—	<ul style="list-style-type: none"> [Enter] key: saves the setting and shifts to the previous menu. [Cancel] key: cancels the setting and shifts to the previous menu.  5.1.1.1 User Type menu

(2) MediaWidth menu

Setup item	Setting	Description
MediaWidth	**** mm	Display the media width that is detected while initializing.
	—	<ul style="list-style-type: none"> [Cancel] key: shifts to the previous menu. ☞ 5.1 Setup menu

5.1.6 Output Mode menu

Sets the media operation after printing.

NOTE

- When the take-up unit is not installed, do not set Output mode to "Take-up". By doing so, the product will be unable to function properly.
- When the Output Mode menu is set to "Take-up", the setting for the Prev. Stick menu is disabled.

[☞ 5.1.9 Prev. Stick menu](#)

Setup item	Setting	Description
Output mode	<Off>	Set when not cutting the media automatically after printing. (Set it to "Off" even when cutting the media manually.)
	Take-up	Set when using the take-up unit. (The media will not be cut after printing.)
	Auto Cut	Set when cutting the media automatically. ☞ 5.1.7 Method of Cut menu
	—	<ul style="list-style-type: none"> [Enter] key: saves the setting and shifts to the sub menu. ☞ 5.1.6.1 Ink Drying Time Menu [Cancel] key: cancels the setting and shifts to the previous menu. ☞ 5.1 Setup menu

5.1.6.1 Ink Drying Time Menu

This menu is used to set ink drying time.

Setup Item	Setting	Description
Ink drying time	<0sec> to 60min	Set the ink drying time.
	—	<ul style="list-style-type: none"> [Enter] key: Saves the set value and shifts to the previous menu. [Cancel] key: Cancels the setting and shifts to the previous menu. ☞ 5.1.6 Output Mode menu

5.1.7 Method of Cut menu

Sets the media cutting operation after printing.



NOTE

- When the the media detection is set to "Off", the media cannot be cut automatically.
- Some media may not be cut (cannot be cut at all or cannot be cut finely). In such a case, set the "Output Mode menu" to "Off" and cut the media manually.

 [5.1.6 Output Mode menu](#)

 [4.4.4 Cutting media manually](#)

- The cutting direction is different depending on the firmware version.

Setup item	Setting	Description
Method of Cut	SingleCut-2 steps	Cuts at a shorter process than SingleCut-3 steps method. Suitable for media with a narrow width.
	<SingleCut-3 steps>	Normal cutting method.
	DoubleCut-2 steps	Set when the media is not cut with SingleCut-2 steps method. Suitable for media with a narrow width.
	DoubleCut-3 steps	Set when the media is not cut with SingleCut-3 steps method.
	—	<ul style="list-style-type: none"> • [Enter] key: saves the setting and shifts to the previous menu. •  5.1.7.1 Cut Pressure menu • [Cancel] key: cancels the setting and shifts to the previous menu. •  5.1 Setup menu

5.1.7.1 Cut Pressure menu

Sets the media cutting pressure for the cutting operation.

Setup item	Setting	Description
Cut Pressure	Low	Cut the media at low pressure. Suitable for thin media or if the "High" pressure setting is too strong.
	<High>	Normal cutting pressure
	-	<ul style="list-style-type: none"> [Enter] key: saves the setting and return to the previous menu. [Cancel] Key: Cancel the set value, and return to the previous menu.  5.1.7 Method of Cut menu

5.1.8 Origin menu

Sets the beginning of printing (origin) of the print data.

Set the menu when reprinting on the margin with changing the printing data position to the printed media.

NOTE

- When Output Mode menu is set to "Take-up", the set value X (media feeding distance) becomes 0 mm to 15000 mm.
↳ [5.1.6 Output Mode menu](#)
 - Depending on the set value of the side margin, the maximum set value of Y (print head transferring distance) decreases.
↳ [5.1.3 Side Margin menu](#)
-

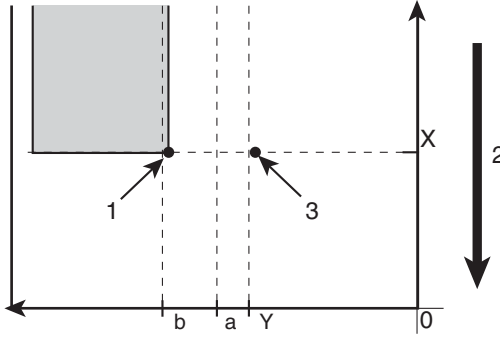
Setup item	Setting	Description
Origin	<ul style="list-style-type: none"> X (media feeding distance): -15000 mm to 15000 mm Y (print head transferring distance): 0 mm to 1151 mm 	<p>Change the print head position and media feeding distance with the following keys.</p> <ul style="list-style-type: none"> [>] key: Decreases the print head transferring distance [<] key: Increases the print head transferring distance [+] key: Increase the media feeding distance. [-] key: Decrease the media feeding distance.  <p>1. Starting position 2. Media feeding direction 3. Setting position of "Origin menu"</p> <p>X (media feeding distance) Y (print head transferring distance) a (0mm/5mm: The spitting setting is On, Off/On Media) b (5mm to 25mm: Side margin setting amount)</p> <p>NOTE</p> <ul style="list-style-type: none"> Depending on the setting, the right margin is a sum of the following. "Y (print head transferring distance) of the Origin menu" + "5mm (when the spitting setting is "On Media")" + "value set on side margin menu" <p>5.1.2 Spitting menu 5.1.3 Side Margin menu</p>
Confirm Position -> Enter		<ul style="list-style-type: none"> [Enter] key or after a certain period of time: Determines the setting. Print head returns to the original position. Save the setting and shift to the previous menu. 5.1 Setup menu
—		<ul style="list-style-type: none"> [Cancel] key: cancels the setting and shifts to the previous menu. 5.1 Setup menu

5.1.9 Prev. Stick menu

Sets up to prevent media from sticking when printing starts.

NOTE

- When the Output Mode menu is set to "Take-up", the setting for the Prev. Stick menu is disabled.
 [5.1.6 Output Mode menu](#)

Setup item	Setting	Description
Prev. Stick	<Off>	The stick-prevent operation is not performed.
	On	The stick-prevent operation is performed. Feed the media back and forth to prevent from sticking.
	—	<ul style="list-style-type: none"> • [Enter] key: saves the setting and shifts to the previous menu. • [Cancel] key: cancels the setting and shifts to the previous menu.  5.1 Setup menu

5.1.10 StandbyHeating menu

Sets the time to preheat the heater while the printer is n standby mode.

Setup item	Setting	Description
Standby Heating	10 minutes - <60 minutes>	Sets the time to pre-heat the heater. When the preset time has passed, each heater turns Off.
	—	<ul style="list-style-type: none"> • [Enter] key: saves the setting and shifts to the previous menu. • [Cancel] key: cancels the setting and shifts to the previous menu.  5.1.1.1 User Type menu

5.1.11 Head Travel menu

Sets up the range that the print head moves while printing.

Setup item	Setting	Description
CR Movement	<Data>	The print head moves the range of the print data width. The printing speed will be improved since the moving range of the print head is optimized.
	Machine	The print head moves from origin to the maximum printable media width.
	<Media Width>	The print head moves the range of the media width.
	—	<ul style="list-style-type: none"> • [Enter] key: saves the setting and shifts to the previous menu. • [Cancel] key: cancels the setting and shifts to the previous menu.  5.1 Setup menu

NOTE

- The minimum travel range of the printer's CR is 500mm.
- Note that even when the media with a width that is below 500mm is loaded while the printer is set to "Data" or "Media Width", the actual CR travel range does not go below 500mm.

5.1.12 Multi Strike menu

Sets up the overwrite count per line.

Setup item	Setting	Description
Multi Strike	<1 time> to 9 times	Set the overwrite count.
	—	<ul style="list-style-type: none"> • [Enter] key: saves the setting and shifts to the previous menu. • [Cancel] key: cancels the setting and shifts to the previous menu.  5.1 Setup menu

5.1.13 Strike Wait menu

Sets up the waiting time while overwrite printing.

NOTE

- When using the media with a narrow width, the media cannot be warmed up adequately, therefore the print quality may not be preserved.
In such a case, set up the Strike Wait time while overwrite printing to warm up the media adequately before printing.

Setup item	Setting	Description
Strike Wait	<0.0 sec.> to 0.1 sec. to 5.0 sec.	Sets the overwrite wait time.
	—	<ul style="list-style-type: none"> • [Enter] key: saves the setting and shifts to the previous menu. • [Cancel] key: cancels the setting and shifts to the previous menu.  5.1 Setup menu

5.1.14 Slant Check menu

Sets up slanting detection during media loading.

Setup item	Setting	Description
Slant Check	Off	Slant Check is not performed.
	<On>	Slant Check is performed.
	—	<ul style="list-style-type: none"> • [Enter] key: saves the setting and shifts to the previous menu. • [Cancel] key: cancels the setting and shifts to the previous menu.  5.1 Setup menu

5.1.15 Auto Cleaning menu

Configure the settings for the auto-cleaning operation.

TIP

•The cleaning mode reflects the settings in the operation panel.

➤ [6.2.3 Head cleaning](#)

Setup item	Setting	Description
Auto Cleaning	WaitingTime	Set the value for auto-cleaning in standby mode. ➤ 5.1.15.1 Idle Auto Cleaning
	Print time	Set the value for auto-cleaning in printing mode. ➤ 5.1.15.2 Printing Mode Auto Cleaning
	Before printing	Set the value for auto-cleaning in pre-printing mode. ➤ 5.1.15.3 Pre-printing Mode Auto Cleaning
	—	<ul style="list-style-type: none"> • [Enter] key: saves the setting and shifts to the sub menu. • [Cancel] key: shifts to the previous menu. ➤ 5.1 Setup menu



5.1.15.1 Idle Auto Cleaning

Set the auto cleaning interval for standby mode.

Setup item	Setting	Description
WaitingTime	Off - 10 mins - <360 mins> - 1440 mins	Sets the time for auto-cleaning in WaitingTime mode. <ul style="list-style-type: none"> • Off: Auto cleaning is not performed. • Others: Perform the head cleaning selected in Cleaning menu after the setting time has elapsed. ➤ 6.2.3 Head cleaning
	—	<ul style="list-style-type: none"> • [Enter] key: saves the setting and shifts to the previous menu. • [Cancel] key: cancels the setting and shifts to the previous menu. ➤ 5.1.15 Auto Cleaning menu



5.1.15.2 Printing Mode Auto Cleaning

Set the auto cleaning interval for printing mode.

Setup item	Setting	Description
PrintingTime	<Off> to 5 mins to 180 mins	Selects the time for auto-cleaning while printing. <ul style="list-style-type: none"> • Off: Auto cleaning is not performed. • Others: Perform the head cleaning selected in Cleaning menu after the setting time has elapsed.  6.2.3 Head cleaning
	—	<ul style="list-style-type: none"> • [Enter] key: saves the setting and shifts to the previous menu. • [Cancel] key: cancels the setting and shifts to the previous menu.  5.1.15 Auto Cleaning menu

5.1.15.3 Pre-printing Mode Auto Cleaning

Set the value for auto-cleaning in pre-printing mode.

Setup item	Setting	Description
Before Print	<Off>	The auto cleaning is not performed.
	On	<ul style="list-style-type: none"> • Perform the head cleaning selected in the Cleaning menu before printing.  6.2.3 Head cleaning
	—	<ul style="list-style-type: none"> • [Enter] key: saves the setting and shifts to the previous menu. • [Cancel] key: cancels the setting and shifts to the previous menu.  5.1.15 Auto Cleaning menu

5.1.16 Ink Status menu

Displays the various information of smart chips.

5.1.16.1 SmartChip menu



NOTE

- To display the various information of Smart chips, use genuine ink and S/C cards. If ink other than genuine ink is used, the ink status will not be displayed correctly.

Setup item	Setting	Description
KCMY	0 to 100 (unit: %)	The amount of ink remaining in each ink cartridge of K/C/M/Y is displayed.
	—	<ul style="list-style-type: none"> [Cancel] key: shifts to the previous menu.  5.1 Setup menu

5.1.17 Roll Length menu

Sets up the roll media length.

Setup item	Setting	Description
Roll media	<Off>	Roll Length is not used. <ul style="list-style-type: none"> [Enter] key: saves the setting and shifts to the previous menu.  5.1 Setup menu
	Roll1	Sets up the roll media length. The set values of the roll media length can be set as "Roll1" to "Roll3". <ul style="list-style-type: none"> [Enter] key: saves the setting and shifts to the sub menu.  5.1.17 Roll Length menu
	Roll2	
	Roll3	
	—	<ul style="list-style-type: none"> [Cancel] key: cancels the setting and shifts to the previous menu.  5.1 Setup menu

5.1.17.1 Roll Length menu

Sets up the roll media length.

NOTE

- After replacing the roll media, set the roll media length again.
If the roll media length is not set, the residual quantity of roll media may not be displayed correctly.

Setup item	Setting	Description
Length	1 m to <30 m> to 200 m	Sets the roll media length.
	—	<ul style="list-style-type: none"> • [Enter] key: saves the setting and shifts to the previous menu. • [Cancel] key: cancels the setting and shifts to the previous menu. 🔑 5.1 Setup menu

5.1.18 Longstore menu

Wash the print head with the cleaning fluid.

NOTE



- Make sure to use the dedicated cleaning fluid (Model number: VJ-MSINK3-CL220/VJ-MSINK3-CL1000).

Setup item	Setting	Description
Longstore	Start	Wash the print head with the cleaning fluid. <ul style="list-style-type: none"> • [Enter] key: Performs the head washing operation. The following content is displayed on the operation panel.
	Remove Cartridges	Remove the ink cartridge, and install the cleaning cartridge. 🔑 6.1.1 Replacing ink cartridges
	—	<ul style="list-style-type: none"> • [Cancel] key: shifts to the previous menu without Head washing. 🔑 5.1 Setup menu

5.1.19 CR Maintenance menu

Performs maintenance.

Used in the following cases.

- Cleaning the cleaning wiper
 [6.2.4 Cleaning the cleaning wiper](#)
- Cleaning around the print head
 [6.2.5 Cleaning around the print head](#)
- Replacing Cutter
 [6.1.3 Replacing Cutter](#)

Setup item	Setting	Description
CR Maintenance	Start	Performs maintenance. <ul style="list-style-type: none"> • [Enter] key: Print head moves to the left. Cleaning wiper rises.
		The following content is displayed on Operation panel. "End" <ul style="list-style-type: none"> • [Enter] key: Cleaning wiper returns to the original position. Print head returns to the original position.
	—	<ul style="list-style-type: none"> • [Cancel] key: shifts to the previous menu without maintenance.  5.1 Setup menu
	—	<ul style="list-style-type: none"> • Perform the pumping operation (start/stop) by pressing the “-” key while displayng “CR Mainte.: End”.

5.1.20 Initialization menu

Returns the settings of the printer to default.

Setup item	Setting	Description
Initialization	ALL	All settings can be returned to factory default.
	User Type	The setting of the User Type is returned to factory default.
	Settings other than User Type	The setting other than the User Type is returned to factory default.
	—	<ul style="list-style-type: none"> • [Enter] key: "*** Initialing ***" is displayed on the operation panel and the printer initializes the setting. • [Cancel] key: shifts to the previous menu without initialization.  5.1 Setup menu

5.1.21 Life Times menu

Displays the operational life time of each part.

Setup item	Setting	Description
Life Times	Head	Display the operational life of each part. <ul style="list-style-type: none"> • The lifetime of each part is indicated by the asterisks (Maximum 5 asterisks: 100% left). • As the part deteriorates, the number of asterisks decreases one by one (20 %). • The part should be changed when all of the asterisks have disappeared, and "Change" is displayed. Contact your local MUTOH dealer to ask for replacing parts.
	Pump	
	CR Motor	
	PF Motor	
	—	<ul style="list-style-type: none"> • [Cancel] key: shifts to the previous menu.  5.1 Setup menu

NOTE

- When replacing a part that its operational life has ended,
- No charge for replacing within the warranty period or under the contract.
- You are liable for the cost of repairs under conditions other than mentioned above.
- Do not keep using the part which has reached its life span. Problems caused by doing so will not be covered by the warranty.

5.1.22 IP Address menu

Sets the IP address of the printer.

NOTE

- Be sure to set the IP address after consulting the network administrator.

Setup item	Setting	Description
IP Address	000.000.000.000 to <192.168.001.253> to 255.255.255.255	Change the IP address by operating the following keys. <ul style="list-style-type: none"> • [+] key: increases the setting value. • [-] key: decreases the setting value. • [Enter] key: changes the setting for the next segment.
	—	<ul style="list-style-type: none"> • [Cancel] key: saves the setting and shifts to the previous menu.  5.1 Setup menu

5.1.23 Subnet Mask menu

Sets the subnet mask of the printer.

NOTE

- Be sure to set the subnet mask after consulting the network administrator.

Setup item	Setting	Description
Subnet Mask	000.000.000.000 to <255.255.255.000> to 255.255.255.255	Change the subnet mask by operating the following keys. <ul style="list-style-type: none"> • [+] key: increases the setting value. • [-] key: decreases the setting value. • [Enter] key: changes the setting for the next segment. In the 4th segment, it saves the setting and shifts to the previous menu.
	—	<ul style="list-style-type: none"> • [Cancel] key: cancels the setting and shifts to the previous menu. 🔑 5.1 Setup menu

5.1.24 Gateway menu

Sets the gateway.

NOTE

- Be sure to set the gateway after consulting the network administrator.

Setup item	Setting	Description
Gateway	000.000.000.000 to <192.168.001.254> to 255.255.255.255	Change the gateway by operating the following keys. <ul style="list-style-type: none"> • [+] key: increases the setting value. • [-] key: decreases the setting value. • [Enter] key: changes the setting for the next segment. In the 4th segment, it saves the setting and shifts to the previous menu.
	—	<ul style="list-style-type: none"> • [Cancel] key: cancels the setting and shifts to the previous menu. 🔑 5.1 Setup menu

5.1.25 Header Dump menu

This function is to specify whether to print the following information (dump data) of print data.

- Data Header
- Number of Dot in Data (Printed only when the header dump setting is "On".)
- Printer Serial Number
- Firmware Version

NOTE

- The dump data will be used as a reference material to receive technical supports.

TIP

- When a print is executed in connection with computer, the setting of RIP software will be printed in the "Data Header".

Setup Item	Set Value	Description
Header Dump	<Off>	<ul style="list-style-type: none"> • Only a print data will be printed. • Dump data will not be printed.
	On	After printing of print data, the dump data will be printed.
	Dump	<ul style="list-style-type: none"> • Only a dump data will be printed, but the "Number of Dot in Data" will not be printed. • Print data will not be printed.
	—	<ul style="list-style-type: none"> • [Cancel] Key: Save the set value, and return to the previous menu.  5.1 Setup menu

5.2 Test Print Menu

Performs nozzle check of the print head and setup list.

TIP

•Refer to the following for the operation procedure of test print.

☞ [3.5 Test print](#)

Setup item	Description
Nozzle Check	Perform the nozzle check printing. It is used to check whether there are any clogged heads, or missing or blurred prints. ☞ 3.5.1 Nozzle check
Mode Print	Mode print can be performed. Used to confirm the following printing conditions. <ul style="list-style-type: none"> • Print quality • Effect • Pre-heater temperature • Platen heater temperature • Dryer temperature • Adjustment value ☞ 3.5.2 Mode print
Setup List	Setup list printing is performed. Used to check the setup item and the user type. ☞ 3.5.3 Setup print
Palette	Palette print is executed for the color demonstration. ☞ 3.5.4 Palette print
Color Verify	Print the color patches, then measure the color using the optional spectrophotometer (SPECTROVUE VM-10). Compare the currently printed color with the previously printed color to check the color difference. ☞ 3.5.5 Color Verify
—	<ul style="list-style-type: none"> • [Enter] key: "Printing" is displayed on the operation panel and test printing starts. • [Cancel] key: shifts to the previous menu. ☞ 5 Panel setup menu

5.3 Cleaning menu

Performs head cleaning.

TIP

- Head cleaning can be operated when the printer is Normal.
- Refer to the following for operation procedures.

☞ [6.2.3 Head cleaning](#)

Setup item	Description
Short	Discharges smaller amount of ink compared to "Normal".
Normal	Select this mode normally.
Long	Discharges larger amount of ink compare to "Normal". Used when the print head does not improve by normal Head cleaning.
Little Charge	Refills a small amount of ink. Charge a small amount of ink when printing is not stable after initial ink charge. ☞ 3.3 Installing ink cartridges
Initial Charge	Perform this when using the high capacity pack adapter for the first time, for the printer whose ink is filled. ☞ 3.3.3 When using the high capacity pack adapter for the printer whose ink is charged for the first time
—	<ul style="list-style-type: none"> • [Enter] key: "Cleaning **%" is displayed on the operation panel and Head cleaning starts. Progress on the Head cleaning is displayed in % on the operation panel. • [Cancel] key: shifts to the previous menu. ☞ 5 Panel setup menu

5.4 Menu Option menu

Sets up the contents of the Setup menu.

You can make setup items that you do not normally use invisible.

Switch the setting "On (displayed)" to "Off (undisplayed)" using the [<] key or [>] key on the operation panel.

When the setting is On, "*" is displayed on the operation panel.

NOTE

- Even if you select "Off" in the Menu Option menu, you can display the settings temporarily by selecting "Temporary" in the Setup menu.

 [5.1 Setup menu](#)

Setup item	Setting	Description
User Type	Off	Sets up whether to display the User Type menu.
	<On>	
Spitting	Off	Sets up whether to display the Spitting menu.
	<On>	
Side Margin	Off	Sets up whether to display the Side Margin menu.
	<On>	
Media Initial	Off	Sets up whether to display the Media Initial menu.
	<On>	
MediaWidth	Off	Sets up whether to display the MediaWidth menu.
	<On>	
Output Mode	Off	Sets up whether to display the Output Mode menu.
	<On>	
Method of Cut	Off	Sets up whether to display the Method of Cut menu.
	<On>	
Origin	Off	Sets up whether to display the Origin menu.
	<On>	
Prev. Stick	Off	Sets up whether to display the Prev. Stick menu.
	<On>	
Standby Heating	Off	Sets up whether to display the StandbyHeating menu.
	<On>	
Head Travel	Off	Sets up whether to display the Head Travel menu.
	<On>	
Multi Strike	Off	Sets up whether to display the Multi Strike menu.
	<On>	

Setup item	Setting	Description
Strike Wait	Off	Sets up whether to display the Strike Wait menu.
	<On>	
Slant Check	Off	Sets up whether to display the Slant Check menu.
	<On>	
Auto Cleaning	Off	Sets up whether to display the Auto Cleaning menu.
	<On>	
Ink Status	Off	Sets up whether to display the Ink Status menu.
	<On>	
Roll Length	Off	Sets up whether to display the Roll Length menu.
	<On>	
Exhaust fan	<Off>	Exhaust fan menu is not displayed for this printer.
Longstore	Off	Sets up whether to display the Longstore menu.
	<On>	
CR Maintenance	Off	Sets up whether to display the CR Maint. menu.
	<On>	
Initialization	Off	Sets up whether to display the Initialization menu.
	<On>	
Life Times	Off	Sets up whether to display the Life Times menu.
	<On>	
IP Address	Off	Sets up whether to display the IP Address menu.
	<On>	
Subnet Mask	Off	Sets up whether to display the subnet mask.
	<On>	
Gateway	Off	Sets up whether to display the Gateway menu.
	<On>	
Header dump	Off	Specify whether to display the header dump menu.
	<On>	
ALL On		<p>Displays all items in the Setup menu.</p> <ul style="list-style-type: none"> Pressing the [Enter] key displays "*" for all items in the Menu Option menu. <p>NOTE</p> <ul style="list-style-type: none"> The items under Exhaust fan menu remain Off.

Setup item	Setting	Description
ALL Off		No items in the Setup menu are displayed. <ul style="list-style-type: none">• Pressing the [Enter] key deletes "*" for all items in the Menu Option menu.• Even if you select "ALL Off", you can display the items temporarily by selecting "Temporary" in the Setup menu.
	—	<ul style="list-style-type: none">• [Cancel] key: saves the setting and shifts to the previous menu.  5 Panel setup menu

5.5 Version menu

Displays the versions of the firmware.

Setup item	Setting	Description
Ver. M/C	*.**(Main side)/ *.**(Controller side)	Displays the versions of the firmware of the main side (M) and controller side (C).
	—	<ul style="list-style-type: none">[Cancel] key: shifts to the previous menu.  5 Panel setup menu

5.6 Sleep Mode menu

Sleep mode settings are configured.

When you activate sleep mode, the printer operates as follows.



- The vacuum fan stops.
- All heaters stop.
- All lamps turn off except for the power lamp.
- Automatic head cleaning is performed after the time set in the Timer Setting Menu has elapsed.

 [5.6.1 Timer Setting menu](#)

TIP

- The cleaning mode reflects the settings in the operation panel.

 [6.2.3 Head cleaning](#)

Setup item	Setting	Description
Sleep Mode	Set Timer	Set the auto cleaning interval of this printer for Sleep Mode.  5.6.1 Timer Setting menu
	Start	Activate Sleep Mode  5.6.2 Sleep Mode Start menu
	—	<ul style="list-style-type: none"> • [Cancel] key: shifts to the previous menu.  5.1 Setup menu

5.6.1 Timer Setting menu

Set the head cleaning interval of this printer for Sleep Mode.

When more than the set time has passed, the print head is cleaned automatically.

NOTE

- During Sleep Mode, even if the set amount of time has passed, print-head cleaning is not performed under the following circumstances.
- The front cover is open.
- Maintenance cover is open.
- The media loading lever is raised.
- The waste fluid tank is full.
- The ink cartridge is empty.
- The ink cartridge has been removed.
- An object other than an appropriate ink cartridge is inserted in the cartridge slot, etc.

When the printer returns to a normal state, head cleaning is restarted, and Sleep Mode continues.

 [7.2 Error messages](#)

- If one of the above conditions occurs during head cleaning, cleaning is stopped.

When the printer returns to a normal state, head cleaning is restarted.

 [7.2 Error messages](#)

Setup item	Setting	Description
Set Timer	1 hour	When the set time has elapsed, the head cleaning starts.
	2 hours	
	3 hours	
	4 hours	
	5 hours	
	<6 hours>	
	9 hours	
	12 hours	
	18 hours	
	24 hours	
	—	

5.6.2 Sleep Mode Start menu

Activate Sleep Mode

During Sleep Mode, "Restart → Enter" will be displayed in the operation panel.

During Sleep Mode, pressing [Enter] key will return the printer to normal operation.

NOTE

- If the printer is under one of the following conditions while shifting to the Sleep Mode, "Don't Start Sleep Mode" is displayed, and will not shift to the Sleep Mode.
 - The front cover is open.
 - Maintenance cover is open.
 - The media loading lever is raised.
 - The waste fluid tank is full.
 - The ink cartridge is empty.
 - The ink cartridge has been removed.
 - An object other than an appropriate ink cartridge is inserted in the cartridge slot, etc.

Activate Sleep Mode again after returning the printer to a normal state.

 [7.2 Error messages](#)

- If the printer is under one of the conditions above during the Sleep mode, the printer will not return to the Normal condition even pressing the [Enter] key.
Return the printer to a normal state, and press the [Enter] key to return the printer to normal operation.

 [7.2 Error messages](#)

Setup item	Setting	Description
Start	Start Sleep Mode?	<ul style="list-style-type: none"> • [Enter] key: activates Sleep Mode. • [Cancel] key: shifts to the previous menu without activating Sleep Mode.  5.6 Sleep Mode menu
	Restart → Enter	The printer is in Sleep Mode. <ul style="list-style-type: none"> • [Enter] key: return the printer to normal operation.

5.7 Display menu

Sets the language and unit displayed on the LCD monitor of the operation panel.

Setup item	Setting	Description
Display	Language	Sets the language used in the menu items displayed on the LCD monitor of the operation panel. ☞ 5.7.1 Language menu
	Temperature	Sets the unit of temperature display. ☞ 5.7.2 Temperature menu
	Length	Sets the unit to display the length. ☞ 5.7.3 Length menu
	Remain Ink	Sets whether to display the ink level indicator. ☞ 5.7.4 Remain Ink menu
	—	<ul style="list-style-type: none"> [Cancel] key: shifts to the previous menu. ☞ 5 Panel setup menu

5.7.1 Language menu

Sets the language used in the menu items displayed on the LCD monitor of the operation panel.

Setup item	Setting	Description
Language	<English>	Displays the menu items in English.
	Japanese	Displays the menu items in Japanese.
	—	<ul style="list-style-type: none"> [Enter] key: saves the setting and shifts to the previous menu. [Cancel] key: cancels the setting and shifts to the previous menu. ☞ 5.7 Display menu

5.7.2 Temperature menu

Sets the unit of temperature display.

Setup item	Setting	Description
Temperature	<Celsius [°C]>	Displays the temperature in Celsius [°C].
	Fahrenheit [°F]	Displays the temperature in Fahrenheit [°F].
	—	<ul style="list-style-type: none"> [Enter] key: saves the setting and shifts to the previous menu. [Cancel] key: cancels the setting and shifts to the previous menu. ☞ 5.7 Display menu

5.7.3 Length menu

Sets the unit to display the length.

Setup item	Setting	Description
Length	<mm>	Displays the length in millimeters (mm).
	inch	Displays the length in inches (inch).
	—	<ul style="list-style-type: none"> • [Enter] key: saves the setting and shifts to the previous menu. • [Cancel] key: cancels the setting and shifts to the previous menu. 🔗 5.7 Display menu

5.7.4 Remain Ink menu

Sets whether to display the ink level indicator.

Setup item	Setting	Description
Remain Ink	On	Displays the ink level indicator. Refer to the following for the details. 🔗 2.2.4 Ink level indicator 🔗 2.2.4.1 Estimated Ink level graphic
	<Off>	The ink level indicator is not displayed.
	—	<ul style="list-style-type: none"> • [Enter] key: saves the setting and shifts to the previous menu. • [Cancel] key: cancels the setting and shifts to the previous menu. 🔗 5.7 Display menu



5.8 Job Status Menu

Various information of previous print will be displayed.

The length of printed data and if the print is completed will be displayed. When the print is canceled, the information how much the print is completed will be displayed.

Setup item	Setting	Description
Job Status	JobStatus	Displays if the print is completed. When the print is completed: [Completed] When the print is canceled: [Canceled]
	ToDoLength	The total length of print data (media feeding direction) will be displayed.
	Done	The printed length will be displayed.
	Remain	The remaining length of print data will be displayed.
	—	<ul style="list-style-type: none"> [Cancel] key: cancels the setting and shifts to the previous menu.  5 Panel setup menu

TIP

- This function is to check the information of print data with the print operation is completed. For the details on data while printing, please refer to the below.
 -  [4.4.5.2 Settings that can be changed or confirmed while printing](#)
 -  [4.4.8 Normal Display while Printing](#)
- The values displayed in this function are just standard values, not guarantee the accuracy.
- If the print data includes no length data, all information will be displayed as "0".

6 Maintenance

This chapter describes daily maintenance of the product.

6.1 Replacing consumable components

This section describes the replacement time and steps of ink cartridge (or ink packs), roll media, razor blade.

6.1.1 Replacing ink cartridges

This section describes when to replace the ink cartridges.

(1) Replacement time

- a. When "[****] Ink Low" is displayed on the operation panel
 - This message is displayed when there is a small amount of ink remaining in the ink cartridge.
 - The alarm buzzer sounds.
To stop the buzzer, press the [Enter] key on the operation panel.
 - Replace with the new ink cartridge.
- b. When "[****] Ink End" is displayed on the operation panel
 - This message is displayed when there is no ink remaining in the ink cartridge.
 - The alarm buzzer sounds.
To stop the buzzer, press the [Enter] key on the operation panel.
 - Immediately replace it with the new ink cartridge.

NOTE

- [****] in the messages for ink cartridge replacement indicates the color that is almost empty or runs out, using the following characters.
 - K: Black
 - C: Cyan
 - M: Magenta
 - Y: Yellow
- Do not insert or remove the ink cartridge except at the time of replacement. Inserting or removing the ink cartridge mixes air into the ink tube, and failures such as nozzle clogging trouble may occur.
- If "Ink End" is displayed, the printing operation stops.
- If "Ink End" is displayed, you cannot print until inserting the new ink cartridge.
- If there is no cartridge for replacement at hand, leave the empty ink cartridge inserted in the printer. Leaving the printer with the ink cartridge removed may result in clogging of the print head.

(2) Type

Our genuine ink cartridges that are compatible with the printer are as follows.

Description	Model No.
Ink cartridge K (Black: 220 ml)	VJ-MSINK3A-BK220
Ink cartridge C (Cyan: 220 ml)	VJ-MSINK3A-CY220
Ink cartridge M (Magenta: 220 ml)	VJ-MSINK3A-MA220
Ink cartridge Y (Yellow: 220 ml)	VJ-MSINK3A-YE220
Ink cartridge K (Black: 1,000ml)	VJ-MSINK3-BK1000
Ink cartridge C (Cyan: 1,000ml)	VJ-MSINK3-CY1000
Ink cartridge M (Magenta: 1,000ml)	VJ-MSINK3-MA1000
Ink cartridge Y (Yellow: 1,000ml)	VJ-MSINK3-YE1000

NOTE

- To use 1000ml ink packs, high capacity pack adapters (option) are required. For details on high capacity pack adapters, contact your local MUTOH dealer.
- Use genuine ink cartridges for replacement.
This printer is designed to use genuine ink cartridges.
If you use an ink bag that is not a product of the original manufacturer,
- Printing might become blurred, or the end of the ink in the pack might not be detected correctly.
- Any problems caused by using an ink bag other than those recommended above will not be covered by the warranty, and repair expenses will be paid by the customer.

(3) Replacing steps

Follow the procedure below to replace the ink cartridges and high capacity pack adapter.

CAUTION

- **Before operation, make sure to read the Material Safety Data Sheet (MSDS).**
- **When handling ink cartridges or ink packs, pay attention so that ink does not get into your eyes or stick to your skin.**
If ink gets into your eyes or sticks to your skin, immediately wash it off with water.
Failing to do so might cause irritation or light inflammation of eyes.
In case of any abnormality, consult a physician immediately.
- **Do not disassemble ink cartridges or ink packs.**
If disassembled, there is a possibility that ink might come into contact with eyes or skin.

NOTE

- Do not share the ink cartridge once installed with another printer. The cartridge will not be usable from that time onward.
- Do not give ink cartridges or ink packs strong shakes. Doing so may cause ink leakage.
- Do not disassemble ink cartridges. A disassembled ink cartridge or ink packs cannot be used.
- When an ink cartridge or ink pack is moved from a cold place to warm place, keep the ink cartridge for 3 hours or more in the new printing environment before printing.
- Do not refill an ink cartridge or ink pack with ink. It may result in abnormal printing.
- Insert or remove the ink cartridge and high capacity pack adapter at the time of replacement only. Inserting or removing the ink cartridge and high capacity pack adapter except at the time of replacement may result in incorrect printing.

(1) Replacing 220ml ink cartridges

1. Confirm that the printer is turned ON.

NOTE

- Do not replace ink cartridges when the printer is turned OFF. The remaining ink may not be detected correctly, causing abnormal printing.

2. Remove the ink cartridge that you want to replace from the slot.

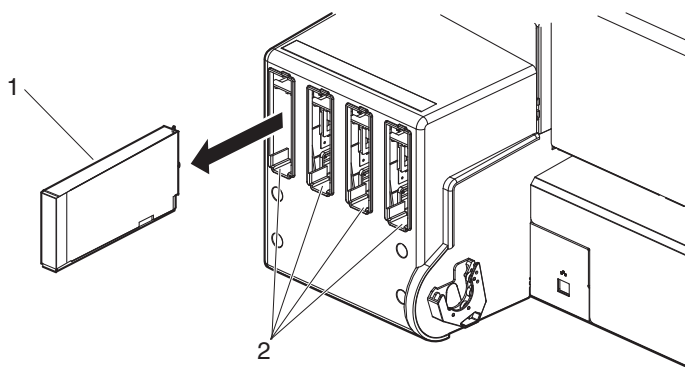

No.	Name
1	Ink cartridge
2	Ink cartridge slots

3. Take out the new ink cartridge from the bag.

NOTE

- Open the bag just before attaching the ink cartridge to the ink cartridge slot. Leaving the ink cartridge with the bag open for a long time may result in abnormal printing.
- Do not insert or remove the ink cartridge more than 10 times. If the ink cartridge has been removed/inserted more than 10 times, it cannot be used even though ink remains.

4. Install a new ink cartridge.
5. Confirm that the operation panel returns to Normal.

NOTE

- If the ink cartridge is replaced during printing, printing resumes.

- Ink cartridge replacement is complete.

(2) Replacing high capacity pack adapter (option)

1. Confirm that the printer is turned ON.

NOTE

- Do not replace high capacity pack adapter when the printer is turned OFF. The remaining ink may not be detected correctly, causing abnormal printing.

2. Remove the high capacity pack adapter that you want to replace from the slot.

NOTE

- Used ink packs should be put in a plastic bag, etc, and dispose of it in compliance with local ordinance and instructions of local authorities.

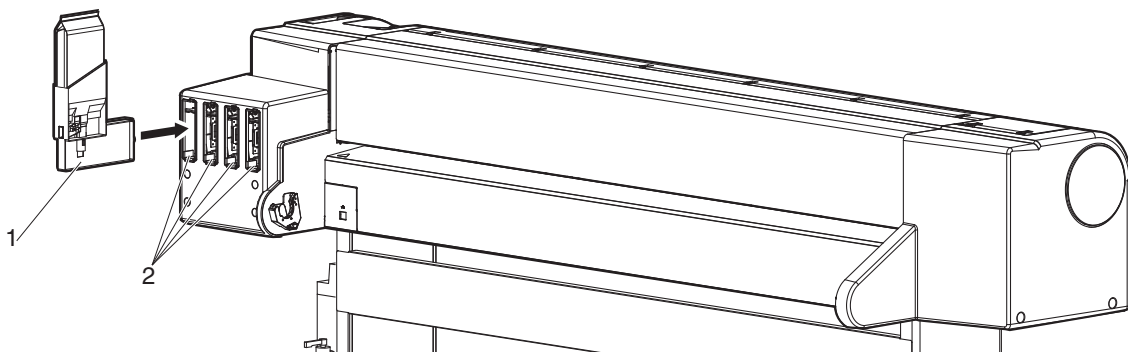

No.	Name
1	High capacity pack adapter
2	Ink cartridge slot

NOTE

- Do not remove only ink pack while high capacity pack adapter is installed on the printer. The information of the remaining smart chip card will be rewritten and the ink pack will not be usable.

3. Take out the new ink pack from the bag.

NOTE

- Open the bag just before attaching the ink pack to the high capacity pack adapter. Leaving the ink pack with the bag open for a long time may result in abnormal printing.

4. Install the ink pack and smart chip card to high capacity pack adapter.

NOTE

- To install or remove the high capacity pack adapter to/from the ink pack and smart chip card, refer to the operation manual included with high capacity pack adapter.

5. Shake the high capacity pack adapter gently two to three times and insert it to the slot.

NOTE

- Make sure that the ink pack and smart chip are installed on the high capacity pack adapter before inserting it to the slot. If the high capacity pack adapter is inserted into the slot without the ink pack, the remaining information will be rewritten and the ink pack will not be usable.

- Insert the high capacity pack adapter all the way to the end of the slot.

6. Confirm that the operation panel returns to Normal.

NOTE

- If the high capacity pack adapter is replaced during a print job, the printer resumes printing.

- Replacing the high capacity pack adapter is complete.

6.1.2 Replacing Roll Media

This section describes when and how to replace the roll media.

(1) Replacement time

Replace the roll media when the following situation occurs.

- a. When the roll media loaded in the printer runs out
 - "End Of Roll" is displayed on the operation panel.
 - If media runs out during printing, the printer stops printing.
- b. When you want to change the media type to use

(2) Type

TIP

- For types and details of the roll media, refer to "[8.3 Options/Supply list](#)".

(3) Replacing steps

Follow the procedure below to replace the roll media.

1. If the printer is turned ON, confirm that operation such as printing is not in progress.
2. Raise the media loading lever.

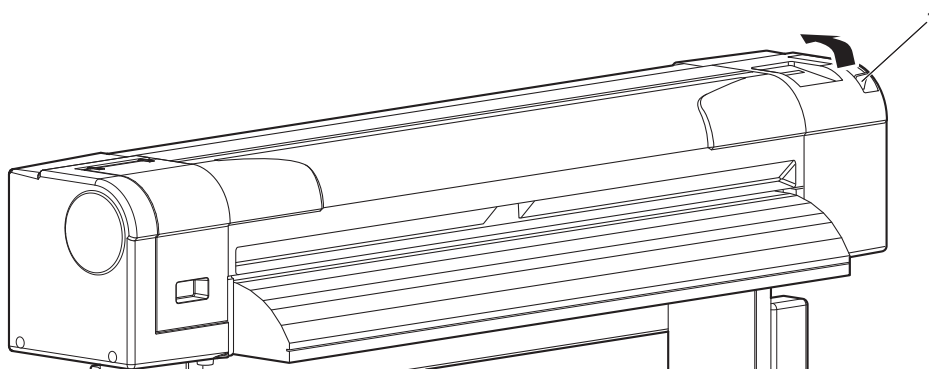

No.	Name
1	Media loading lever

3. Hold the both edges of the scroller to rewind the roll media by hands.

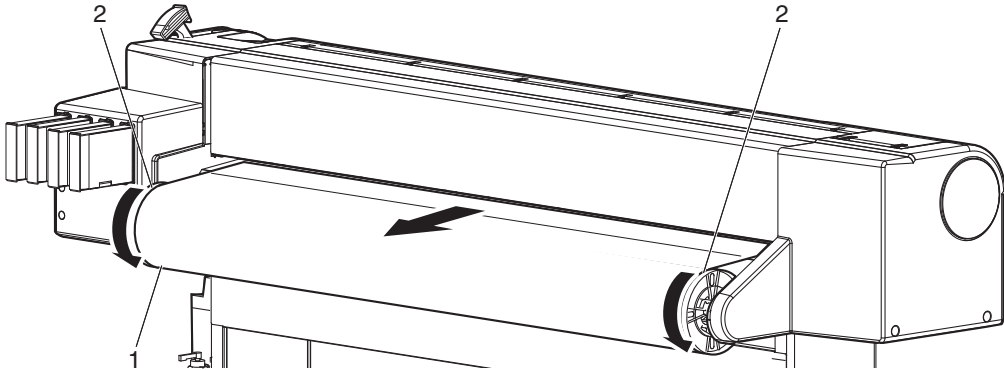

No.	Name
1	Roll media
2	Scroller

4. Remove the scroller unit, and place it on a flat floor.

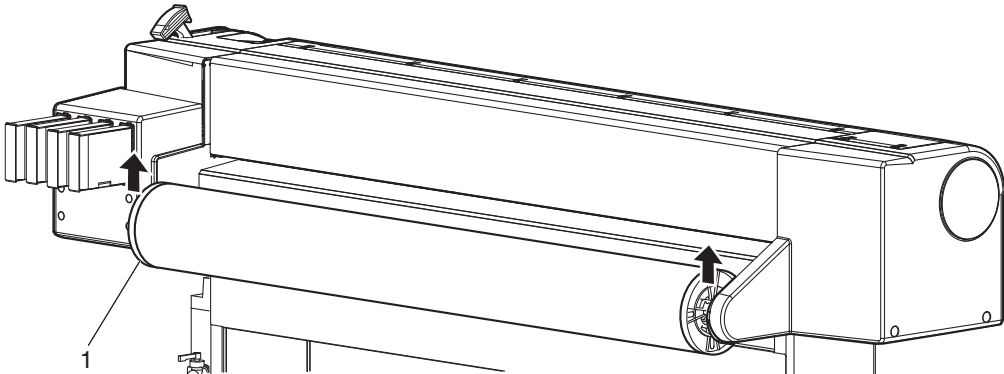

No.	Name
1	Scroller

5. Hold the movable media stopper and lightly tap it as illustrated to remove the movable media stopper.

NOTE

- When removing the roll media, do not strike the left edge of the scroller (on the movable media stopper side) strongly on the floor. The left edge of the scroller may be damaged by the impact.

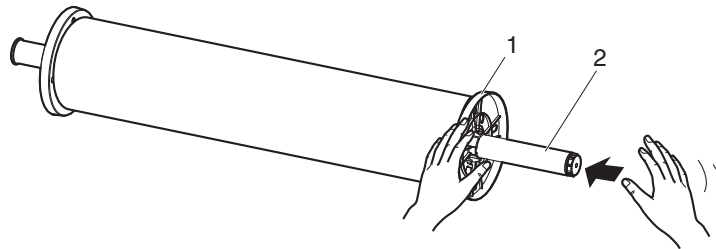

No.	Name
1	Movable media stopper
2	Scroller

6. Remove the roll media from the scroller.

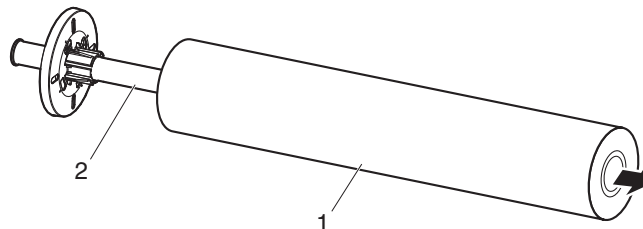

No.	Name
1	Roll media
2	Scroller

7. To load another roll media, refer to the following.

TIP

- For loading the roll media, refer to "[3.4 Loading media](#)".
- For storing the roll media not in use, refer to "[4.2.3 Precaution on storing media](#)".

8. When not loading the roll media, install the movable stopper to the scroller and set the scroller to the printer.

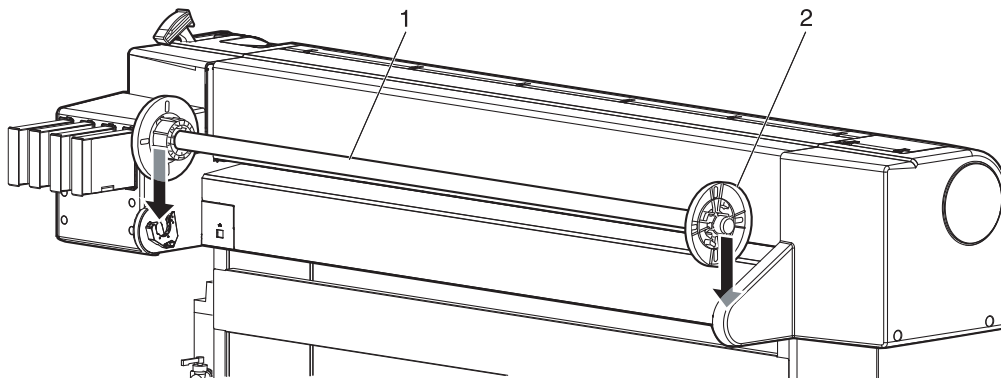

No.	Name
1	Movable media stopper
2	Scroller

6.1.3 Replacing Cutter

This section describes when and how to replace the cutter.

(1) Replacement time

Replace the cutter when the following situation occurs.

- a. When the paper is not cut smoothly
- b. When the cut surface is feathered, etc

(2) Type

Our genuine cutter that is compatible with the printer is as follows.

Description	Model No.
Cutter replacement blade	VJ-CB

(3) Replacing steps

Follow the procedure below to replace the cutter.

1. If the printer is turned ON, make sure the following.
 - Printing or other operations are not in progress.
 - The operation panel display is Normal.
2. Display the CR Maintenance menu on the operation panel.
 - a. Press the [Menu] key on the operation panel.

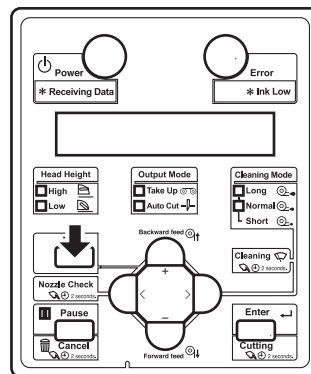

- "Menu 1: Setup>" is displayed on the operation panel.
 - The operation panel shifts to the Setup menu display.
- b. Press the [>] key on the operation panel.

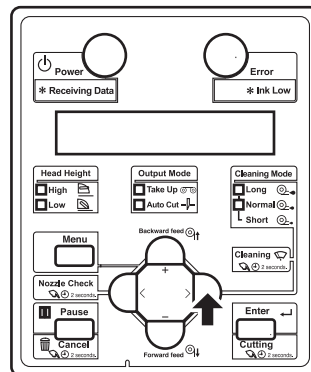

- "Set1: User Type" is displayed on the operation panel.

- c. Press the [+] key or [-] key to select "Set20: CR Maintenance".

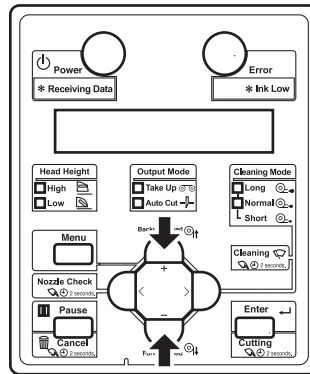

- d. Press the [Enter] key on the operation panel.

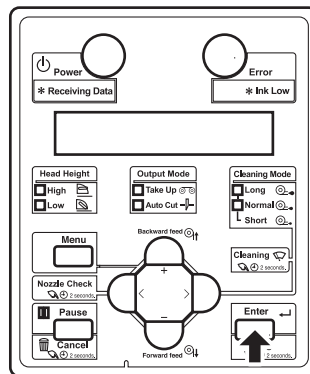

- "CR Mainte.: Start" is displayed on the operation panel.
- The display enters the CR Maintenance menu.

 [5.1.19 CR Maintenance menu](#)

3. Press the [Enter] key on the operation panel.

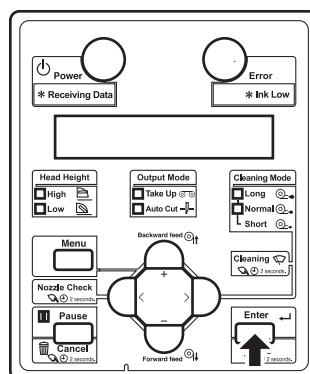

- Maintenance starts.
- The print head moves to the left of the printer (cutter replacement position).
- "CR Maintenance: End" is displayed on the operation panel.

4. Open Maintenance cover.

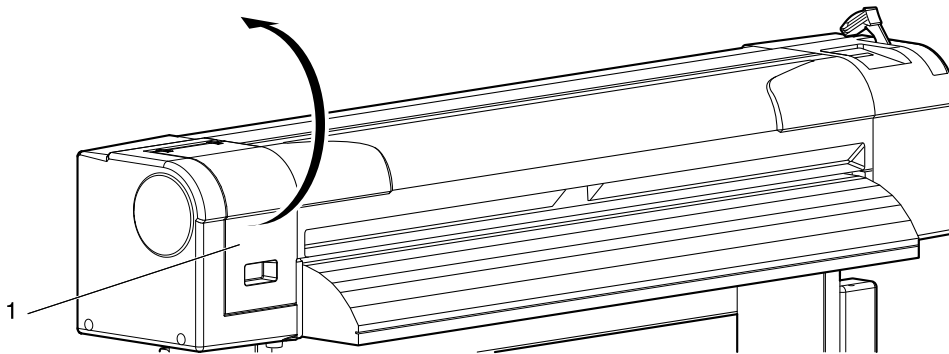

No.	Name
1	Maintenance cover

NOTE

- Replace the cutter in a short time.
Leaving the print head at the cutter replacement position may result in clogging of the print head.

5. Press the tab of the cutter lightly, turn the cutter holder in the direction as illustrated below.

NOTE

- Do not press the tab of the cutter strongly or suddenly let go of it.
There is a spring in the cutter holder and it may fly out.
- Do not push the cutter all the way in.
The cutter blade may damage the inside of the printer.

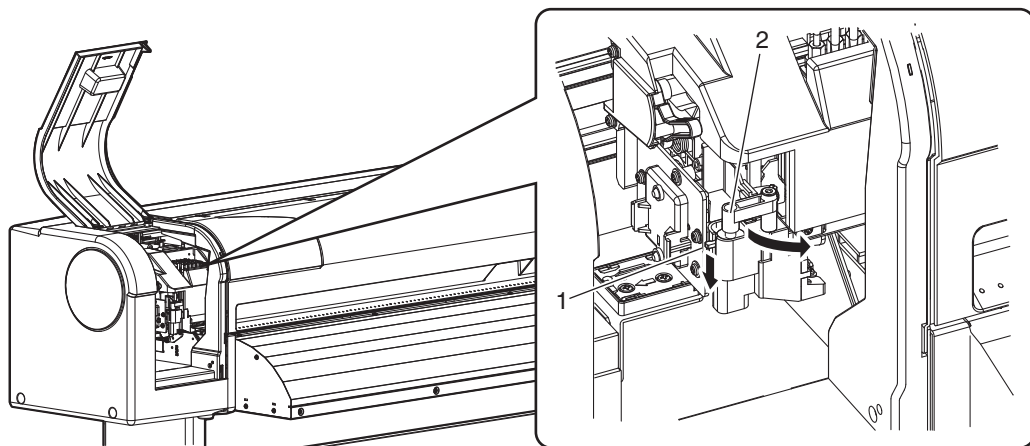

No.	Name
1	Cutter holder
2	Cutter holder lever

6. Remove the cutter.

CAUTION

- Do not touch the blade edge. It may cause an injury.
- Do not touch the cutter blade edge with a hard substance or drop the cutter. The cutter blade may be damaged or chipped.

NOTE

- Used cutter should be put in a plastic bag, etc, and dispose of it in compliance with local ordinance and instructions of local authorities.

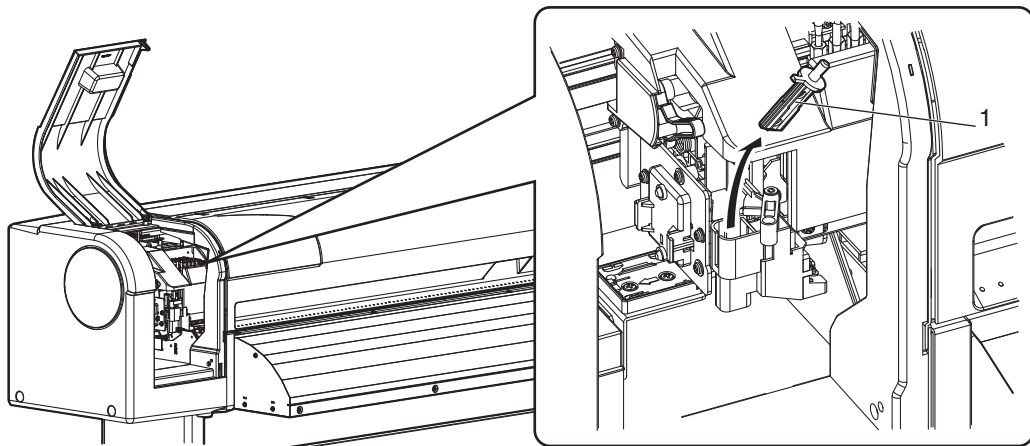

No.	Name
1	Razor blade

7. Install a new cutter as illustrated.

NOTE

- Make sure that the spring in the cutter holder does not fly out while installing.

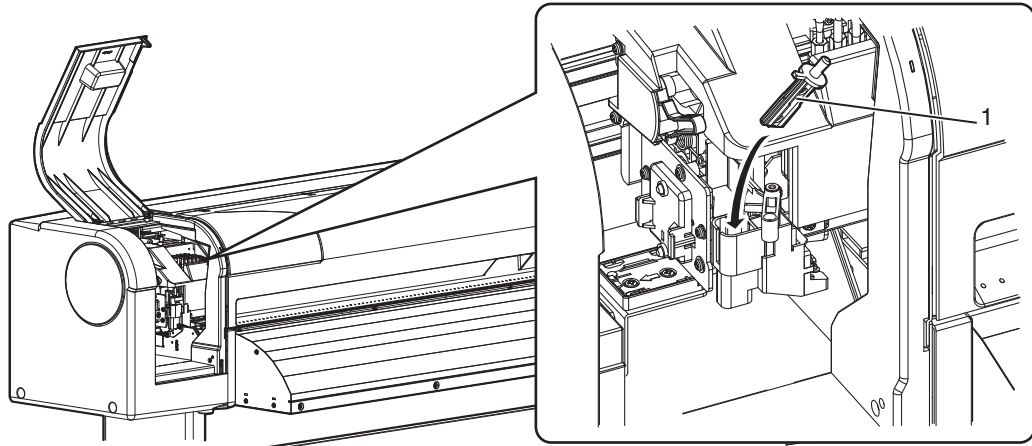

No.	Name
1	Razor blade

8. Press the tab of the cutter lightly, return the cutter holder to its initial position.

NOTE

- Do not press the tab of the cutter strongly or suddenly let go of it.
There is a spring in the cutter holder and it may fly out.
- Do not push the cutter all the way in.
The cutter blade may damage the inside of the printer.
- Refer to the illustrations below and install the cutter holder correctly.
If it is not installed correctly, it may cause an error.
If an error occurs, check if the cutter holder is installed correctly.

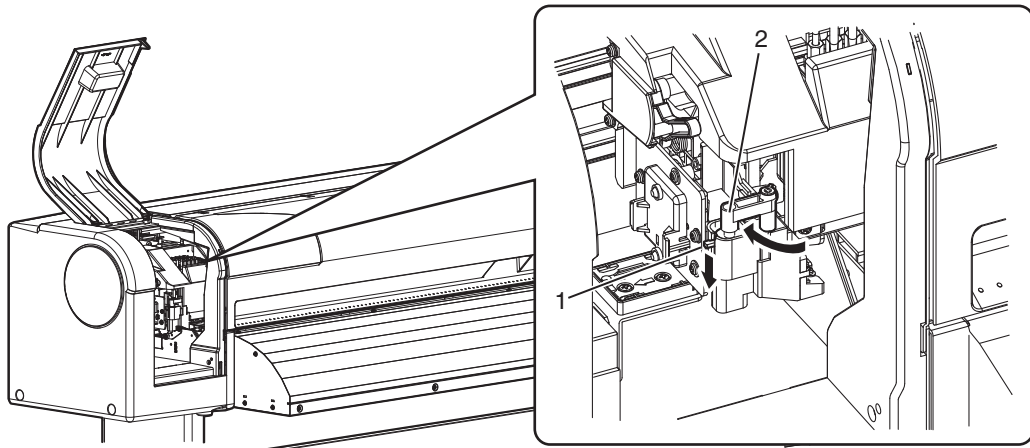

No.	Name
1	Cutter holder
2	Cutter holder lever

9. Close Maintenance cover.

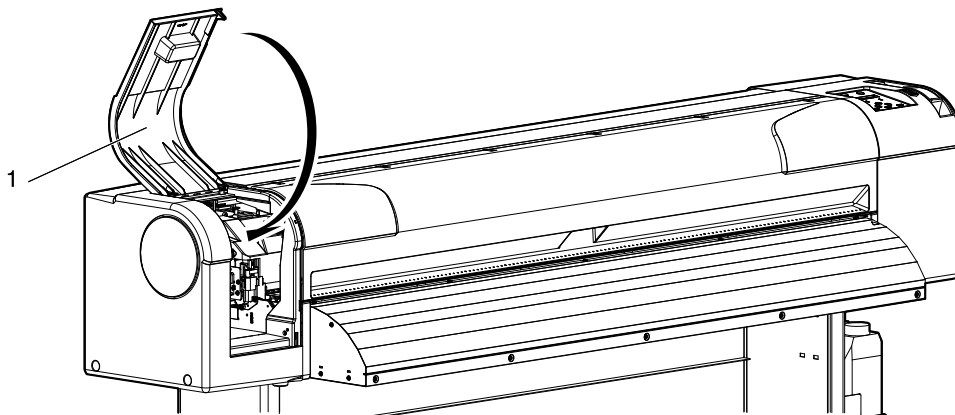

No.	Name
1	Maintenance cover

10. Press the [Enter] key on the operation panel.

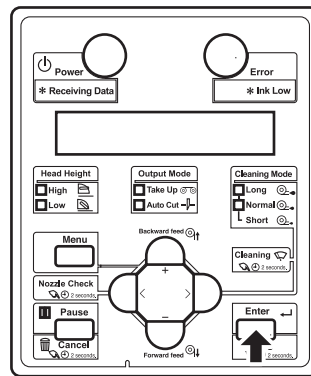

- The print head returns to its original position.
- "CR Mainte.: Start" is displayed on the operation panel.

11. Press the [Menu] key on the operation panel.

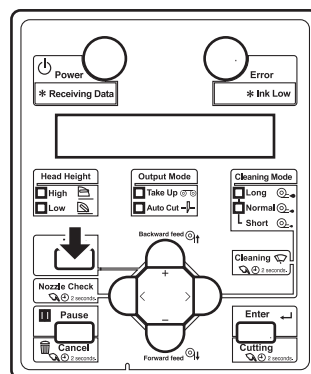

- The printer enters Normal.
- Cutter replacement is complete.

6.2 Cleaning the printer

Periodic (every month) cleaning is necessary to use the printer in good condition.

WARNING

- **Do not insert or drop metal or flammable objects into the printer through openings such as a vent.
It could lead to an electric shock or fire.**
- **If foreign substances or liquids such as water entered the printer, do not use the printer as it is.
It could lead to an electric shock or fire.
Immediately turn OFF the power switch, disconnect the power plug from the electric socket, and contact your local MUTOH dealer.**

CAUTION

- **When cleaning the areas other than the wiper, make sure to turn OFF the power and unplug the power cable.**
- **Do not use volatile solvents such as thinner, benzene, or alcohol.
These solvents could cause damage to the paint.**
- **Be careful that no moisture enters the printer.
There is a possibility that the electric circuit inside the printer is short circuited.**
- **Do not open covers attached using screws under any circumstances.
This may cause an electric shock or a malfunction.**

This section describes how to clean each part of the printer.

6.2.1 Cleaning the outer case

This section describes how to clean the outer case.
Wipe out dust and dirt attached to the outer case by using a soft cloth.

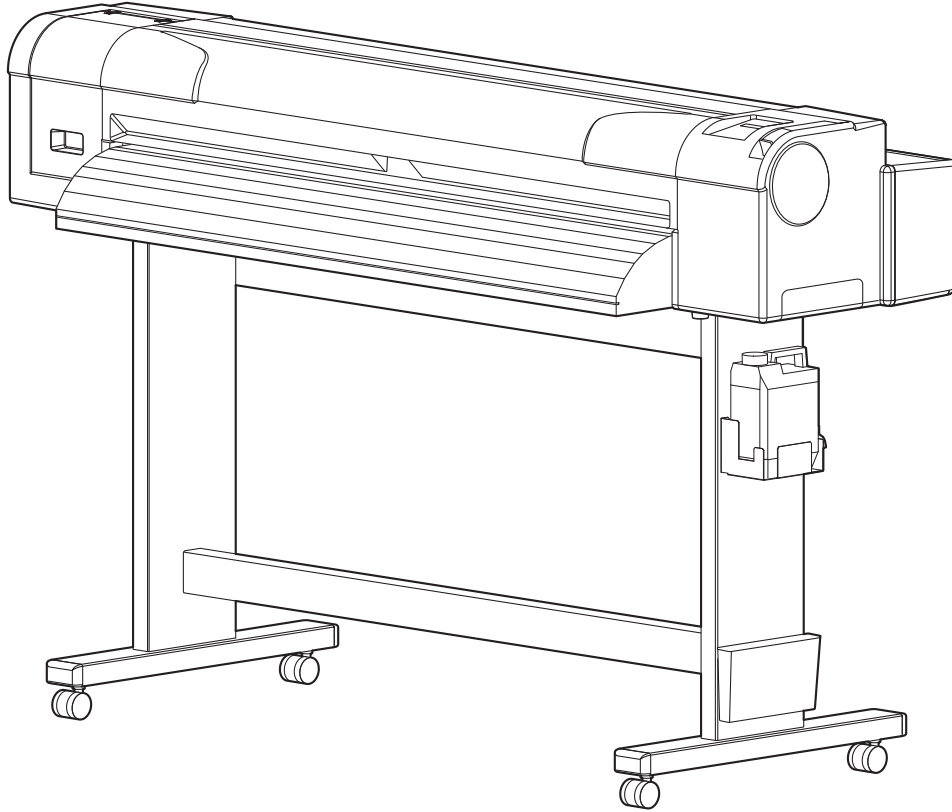

6.2.2 Cleaning the inside of the printer

This section describes how to clean the inside of the printer.

Follow the procedure below.

1. Open the front cover.

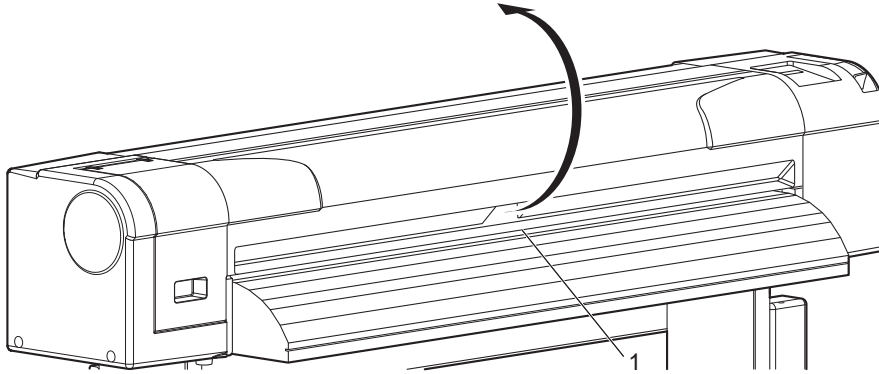

No.	Name
1	Front cover

2. Remove paper powder and dust attached to the pressurizing rollers using a soft brush.

NOTE

- Do not blow paper powder inside the printer using tools such as an air duster. It may cause an abnormal noise from the inside of the printer.

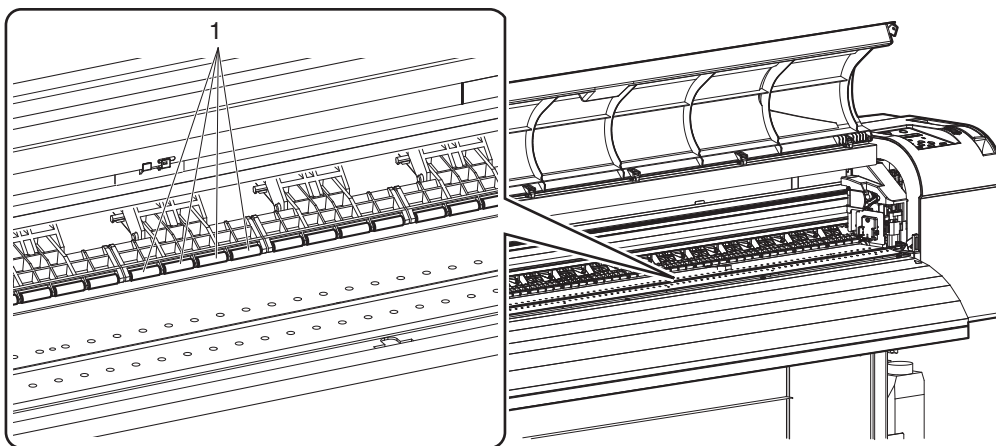

No.	Name
1	Pressurizing rollers

3. Apply a damp and tightly squeezed soft cloth to wipe out paper powder and ink attached to the platen and media guide.

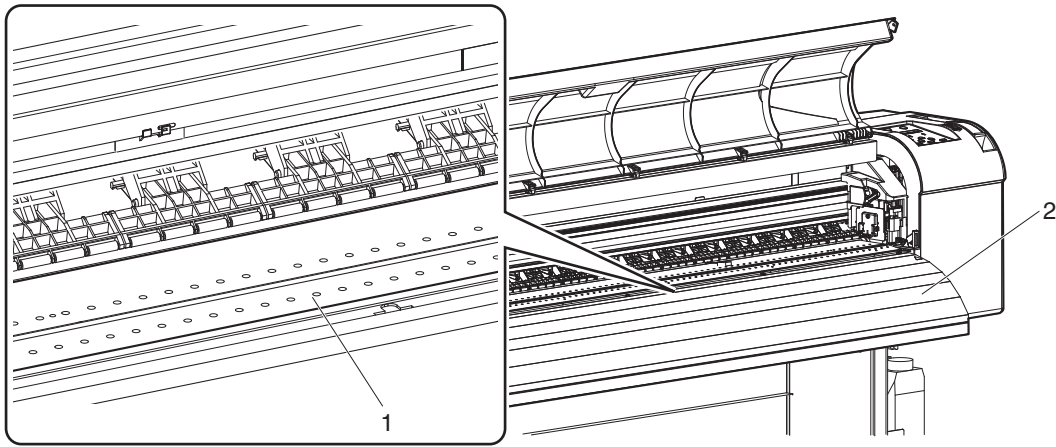

No.	Name
1	Platen
2	Media guide

4. Apply a damp and tightly squeezed soft cloth to wipe off the dirt of the unpainted (silver color) area in the center of the grid roller.

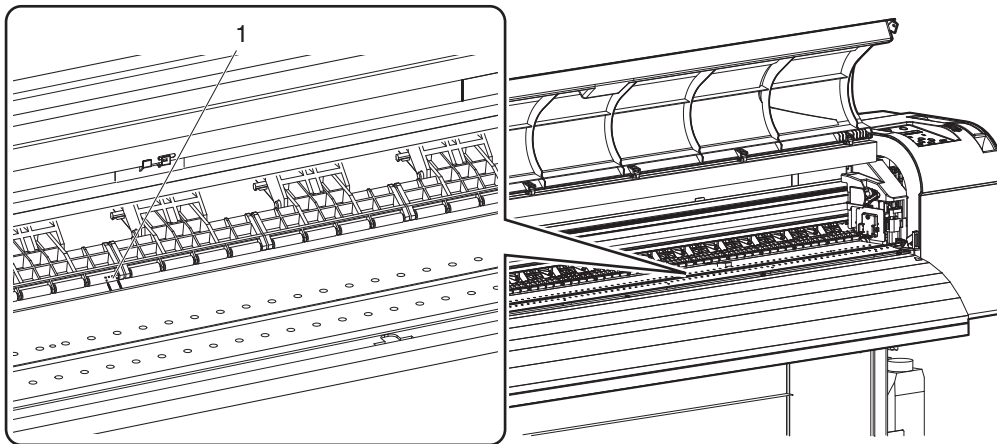

No.	Name
1	Grid roller

6.2.3 Head cleaning

If printed data is blurred or lacks part of it, clean the print head surface and nozzle (Head cleaning).

Follow the procedure below to perform Head cleaning.

NOTE

- When not using the printer for a long period (one week or more), perform Head cleaning once a week.
If not performing Head cleaning, the print head is clogged. Doing so will preserve print quality.
- Remove media when cleaning.
Cleaning with media loaded may lead to contact between the print head and media.

1. Confirm that the operation panel is Normal.
2. Make sure that the media loading lever is lowered.
3. Press the [>] key on the operation panel to select the cleaning mode.

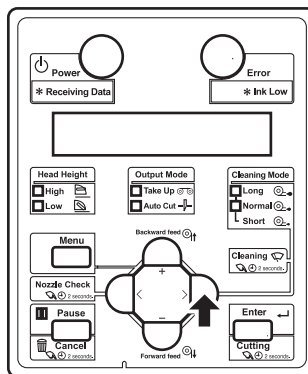

4. Press the [Cleaning] key on the operation panel for at least two seconds.

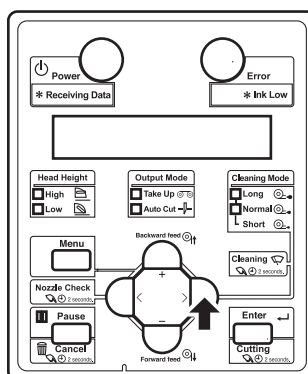

- Start Head cleaning.
- "Cleaning **%" is displayed on the operation panel.
- After Head cleaning is complete, the operation panel shifts to Normal.

NOTE

- If you fail to remove blurs or incompleteness of printing in one Head cleaning, perform strong cleaning.
- If blurs or lacking parts in printed media do not disappear with several times of Head cleaning, refer to "[7 Troubleshooting](#)", and take appropriate measures.

6.2.4 Cleaning the cleaning wiper

This section describes how to clean the cleaning wiper.

(1) Time for cleaning

Once a week, or when blurs or lacking parts appear on printed media after Head cleaning.

(2) Cleaning procedures

Follow the procedure below to clean the cleaning wiper.

NOTE

- Use the cleaning stick to clean the cleaning wiper.
For details of the cleaning stick, refer to "[8.3 Options/Supply list](#)".

1. If the printer is turned ON, make sure the following.
 - Printing or other operations are not in progress.
 - The operation panel display is Normal.
2. Display the CR Maintenance menu on the operation panel.
 - a. Press the [Menu] key on the operation panel.

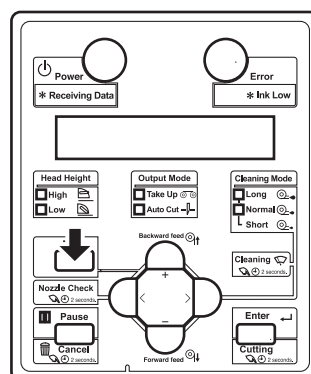

- "Menu1: Setup>" is displayed on the operation panel.

- The operation panel shifts to the Setup menu display.
- b. Press the [>] key on the operation panel.

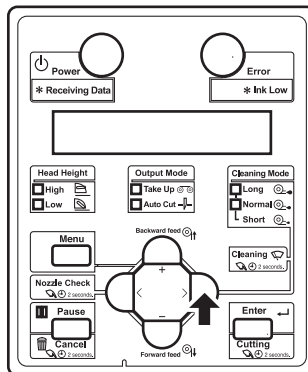

- "Set1: User Type" is displayed on the operation panel.
- c. Press the [+] key or [-] key to select "Set20: CR Maintenance".

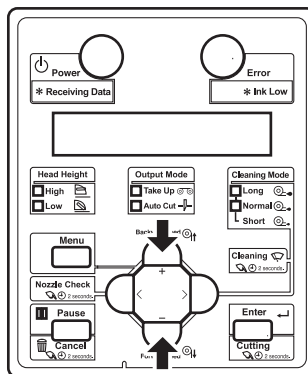

- d. Press the [Enter] key on the operation panel.

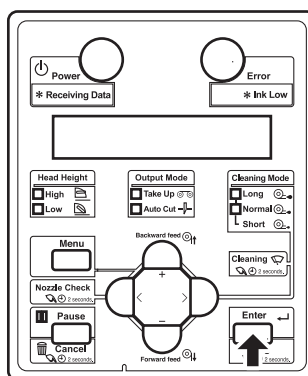

- "CR Mainte.: Start" is displayed on the operation panel.
- The display enters the CR Maintenance menu.

5.1.19 CR Maintenance menu

3. Press the [Enter] key on the operation panel.

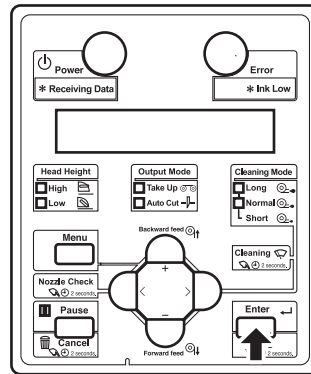

- Maintenance starts.
- The print head moves to the left.
- "CR Mainte.: End" is displayed on the operation panel.

4. Open the front cover.

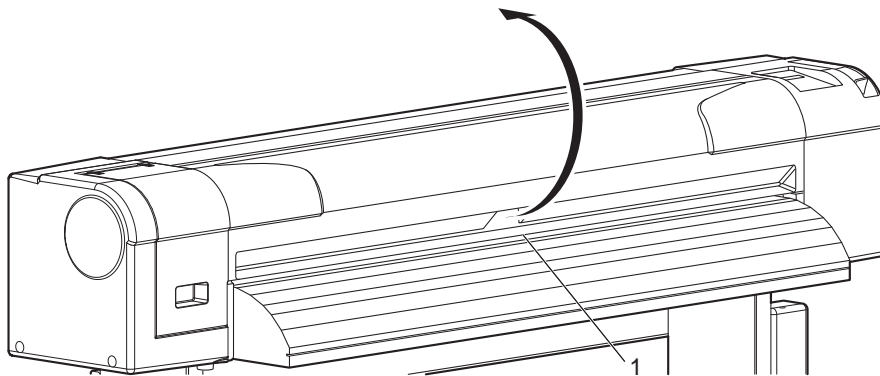

No.	Name
1	Front cover

CAUTION

- When cleaning the cleaning wiper,
- do not touch the cleaning wiper and head cap unit.
Head cleaning may not be performed correctly because of oil from your hands.
- Make sure to wipe the print head using the cleaning stick.
A wet cleaning stick may cause the print head to clog.
- Do not reuse the cleaning stick.
The attached dust, etc may damage the print head.

5. Use the cleaning stick to remove the ink and dust on the cleaning wiper.

- a. Front side of the cleaning wiper:
Remove the ink and dust in the horizontal direction.

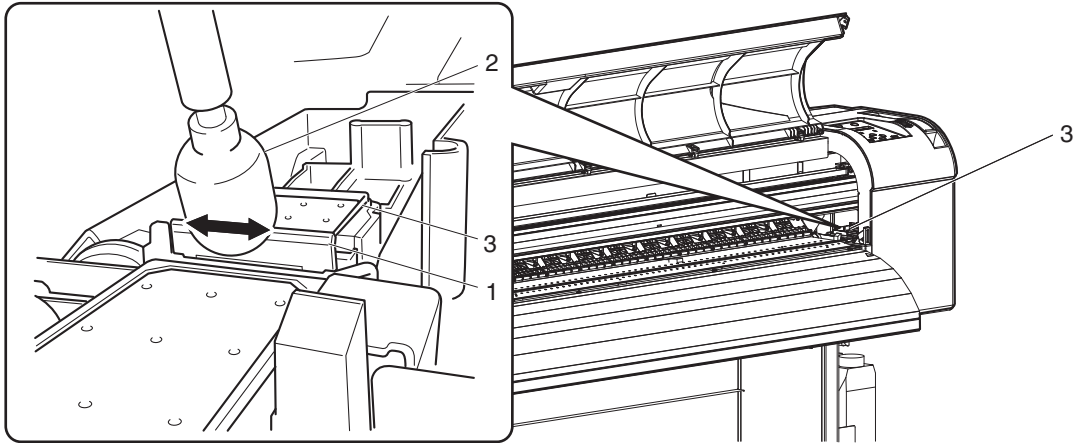

No.	Name
1	Cleaning wiper
2	Cleaning stick
3	Head cap unit

- b. Cleaning wiper back side:
Remove the ink and dust in the upper direction.

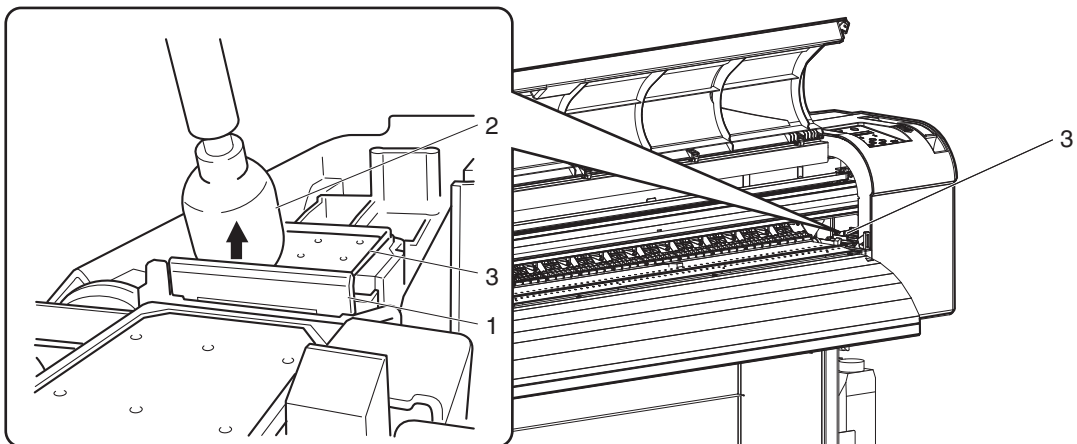

No.	Name
1	Cleaning wiper
2	Cleaning stick
3	Head cap unit

6. Close the front cover.

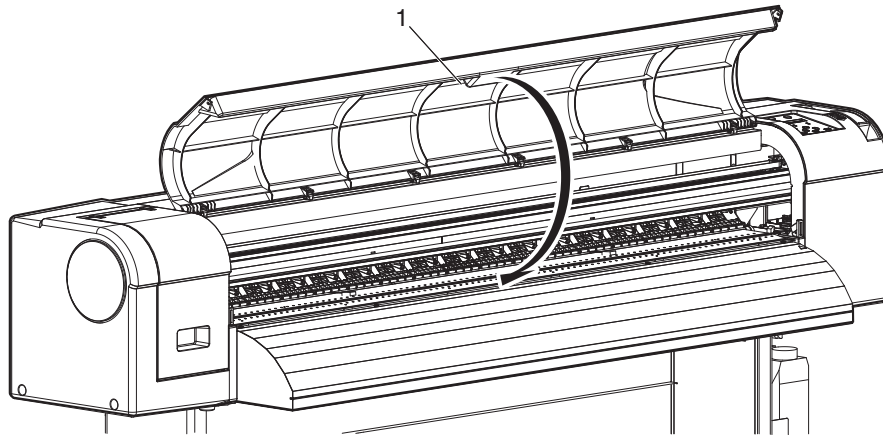

No.	Name
1	Front cover

7. Press the [Enter] key on the operation panel.

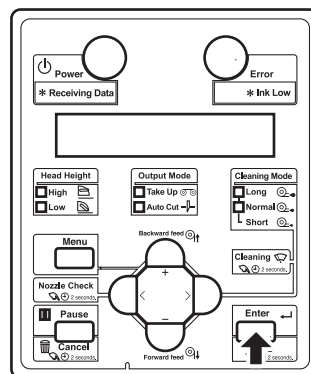

- The print head returns to its original position.
- "CR Mainte.: Start" is displayed on the operation panel.

8. Press the [Menu] key on the operation panel.

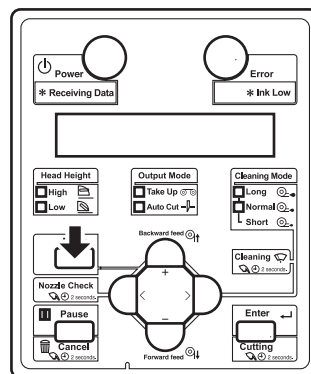

- The printer enters Normal.
- Cleaning the cleaning wiper is complete.

6.2.5 Cleaning around the print head

This section describes how to clean around the print head.

(1) Time for cleaning

When foreign substances such as dust or ink clump that can cause missing dots or ink leakage is attached around the print head

(2) Cleaning procedures

Follow the procedure below to clean around the print head.

NOTE

- Before cleaning around the print head, read this procedure thoroughly to fully understand it, and clean promptly and correctly.
 - While cleaning around the print head, the print head cap is removed, therefore cleaning must be done before the print head dries.
This operation should be done within 15 minutes.
If the operation lasts over 15 minutes, follow the Steps 8 and 9 to stop the operation and perform head cleaning, then resume cleaning.
 [6.2.3 Head cleaning](#)
 - Use the cleaning stick to clean around the print head.
For details of the cleaning stick, refer to "[8.3 Options/Supply list](#)".
-

1. If the printer is turned ON, make sure the following.
 - Printing or other operations are not in progress.
 - The operation panel display is Normal.

2. Display the CR Maintenance menu on the operation panel.
 - a. Press the [Menu] key on the operation panel.

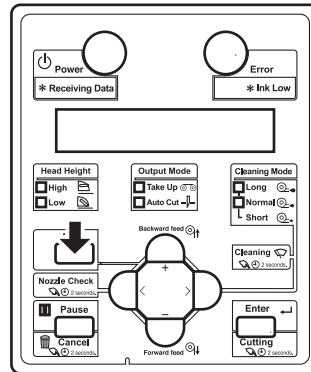

- "Menu1: Setup>" is displayed on the operation panel.
 - The operation panel shifts to the Setup menu display.
- b. Press the [>] key on the operation panel.

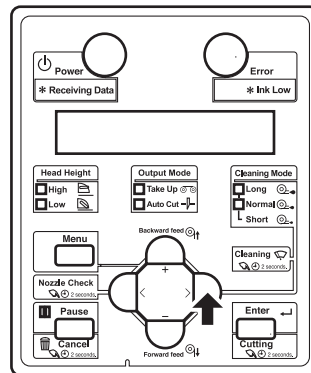

- "Set1: UserType" is displayed on the operation panel.
- c. Press the [+] key or [-] key to select "Set20: CR Maintenance".

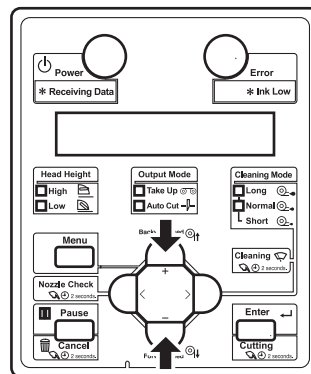

- d. Press the [Enter] key on the operation panel.

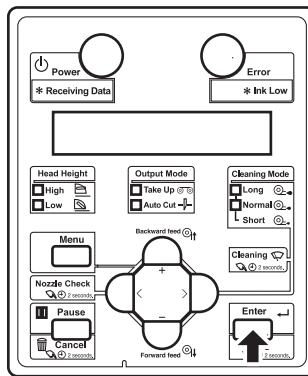

- "CR Maine.: Start" is displayed on the operation panel.
- The display enters the CR Maintenance menu.

 **5.1.19 CR Maintenance menu**

3. Press the [Enter] key on the operation panel.

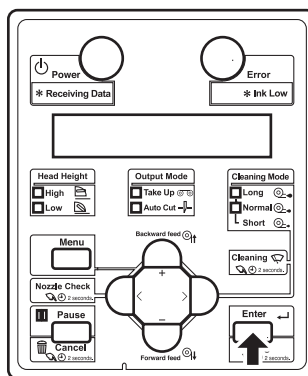

- Maintenance starts.
- The print head moves to the left.
- "CR Maintenance: End" is displayed on the operation panel.

4. Open the maintenance cover on the left of the printer.

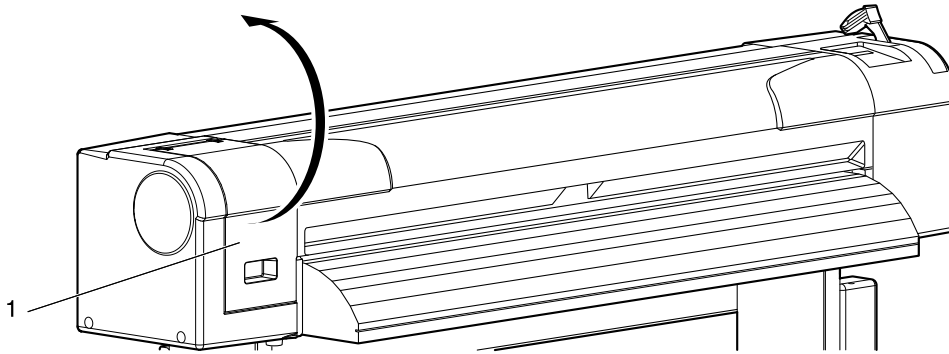

No.	Name
1	Maintenance cover

5. Move the print head section by hand to where the circumference of the Print head is visible.

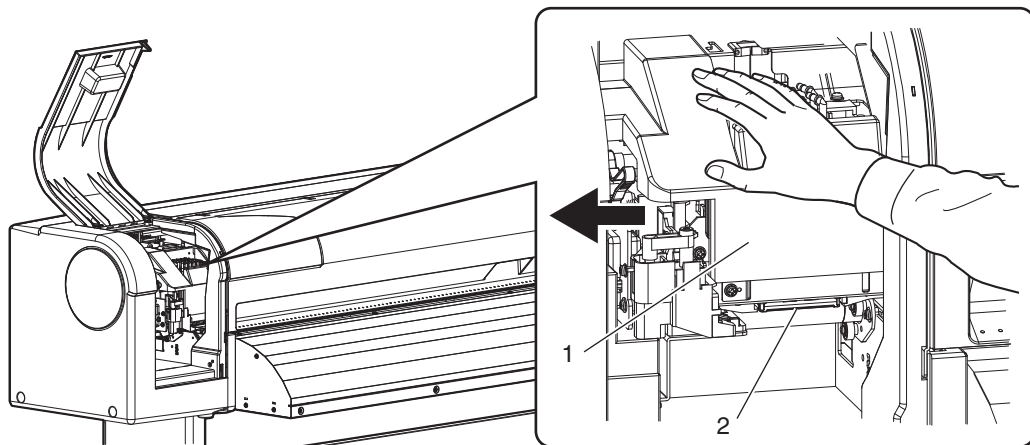

No.	Name
1	Print head section
2	Circumference of the Print head

CAUTION

- Do not press the Print head section strongly. Doing so may cause damage or poor print results.

6. Use a penlight, etc to check if any foreign substance, such as dust or ink clump, is attached to the following places.

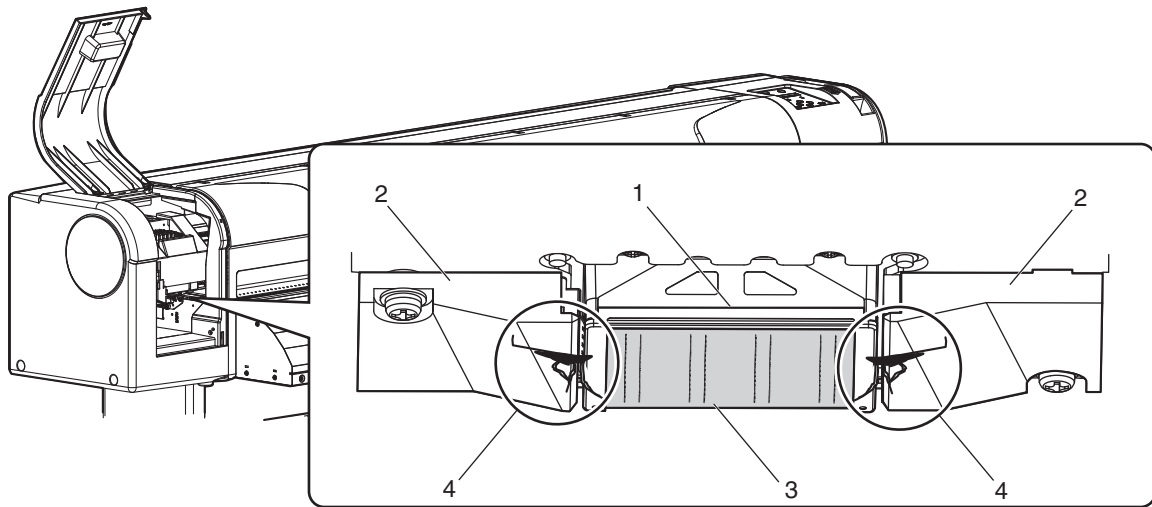

No.	Name
1	Around the print head
2	Head guide
3	Nozzles
4	Dust, ink clump, etc

CAUTION

- **When cleaning around the print head,**
 - **do not touch the nozzles of the print head.**
Doing so may damage the print head.
 - **Do not touch the tip of the cleaning stick.**
The print head may be damaged because of oil from your hands.
 - **Never put water, etc on the tip of the cleaning stick.**
Doing so may damage the print head.
 - **Do not reuse the cleaning stick.**
The attached dust, etc may damage the print head.

7. When some foreign substance such as dust or ink clump is attached, use the cleaning stick to remove it.

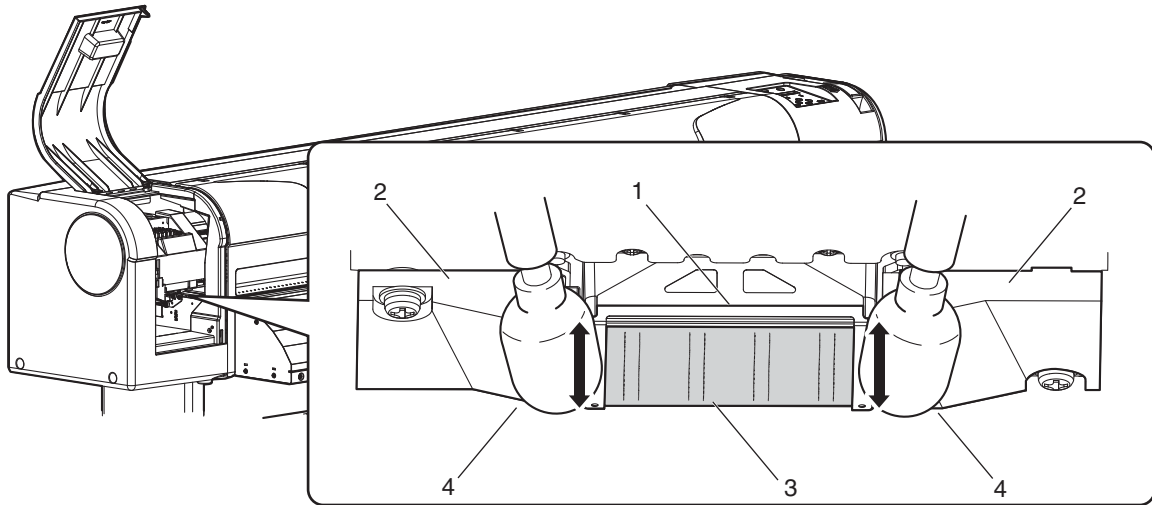

No.	Name
1	Around the print head
2	Head guide
3	Nozzles
4	Cleaning stick

8. Close the left maintenance cover.
 - Close the cover firmly until it is locked.

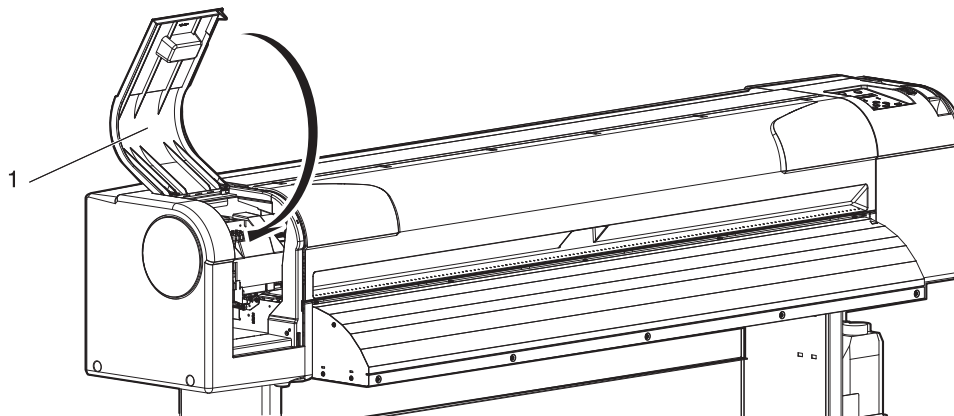

No.	Name
1	Maintenance cover

9. Press the [Enter] key on the operation panel.

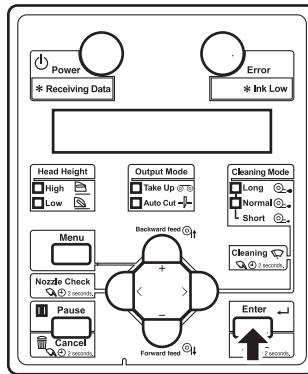

- The print head returns to its original position.
- "CR Maine.: Start" is displayed on the operation panel.

10. Press the [Menu] key on the operation panel.

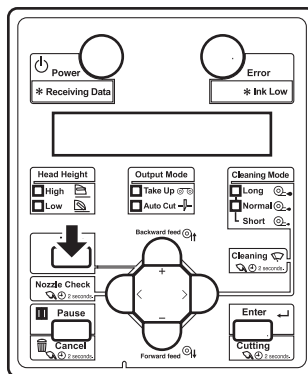

- The printer enters Normal.
- Cleaning around the print head is complete.

6.3 Disposal of waste fluids

The timing and method for the disposal of waste fluid are described below.

(1) Disposal timing

Dispose of waste fluids in the following cases:

- a. When the waste fluid tank is more than half full.
- b. When "Waste Ink Tank Full" is displayed on the operation panel.

(2) Disposal method

Follow the procedure below to dispose of waste fluid.

WARNING

- **The waste fluid from the printer falls under the category of waste oil (waste ink) of industrial waste (out of the 19 items of general waste from business activities). You are obligated to properly dispose of waste fluid in compliance with Wastes Disposal and Public Cleansing Act and local ordinances. Delegate disposal to an industrial waste disposal contractor.**

1. Ready an empty container such as a supply waste fluid bottle, to contain the waste fluid.
2. Lay a protective material on the floor under the waste fluid tank.
3. Open the waste fluid valve, and transfer the waste fluid to the container.

NOTE

- When transferring the waste fluid to the empty container, the waste fluid may spatter. Make sure to put the container close to the waste fluid valve.

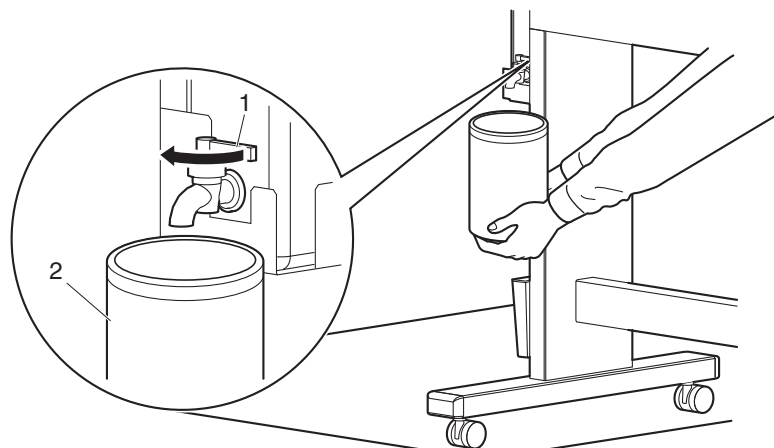

No.	Name
1	Waste fluid valve
2	Empty container

4. After pouring the waste fluid to the empty container, close the waste fluid valve securely.

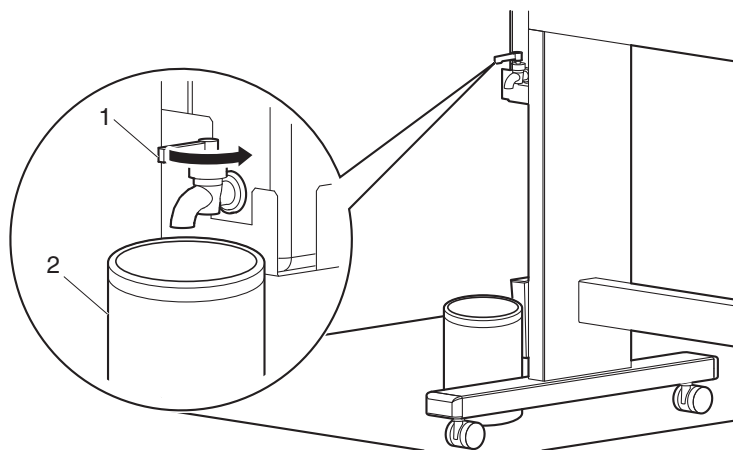

No.	Name
1	Waste fluid valve
2	Empty container

5. Wipe the opening of the waste fluid valve with a cloth, etc.
6. Dispose of the waste fluid as an industrial waste product.
- Disposal of waste fluids is completed.

6.4 Moving or transporting the printer

This section describes how to move or transport the printer.

6.4.1 Moving the printer

This section describes how to move the printer.



CAUTION

- **Move the printer maintaining a horizontal position.**
- **Do not slant the printer, prop it against a wall or turn it upside down.**
There is a possibility that ink inside the printer may leak.
Moreover, normal operation after shifting (to these positions) cannot be guaranteed.

(1) Preparation before moving

When using the dedicated stands, follow the procedure below to move the printer.

1. Dispose of waste fluid.
☞ [6.3 Disposal of waste fluids](#)
2. Make sure that the printer is turned OFF.
3. Make sure that the stands and the wing bolts (2 pieces) retaining the printer are not loose.
4. Make sure that the print head is located on the right edge.
5. Bundle the CR belts located in the center of the printer and clip them with the CR belt clip to fix them.

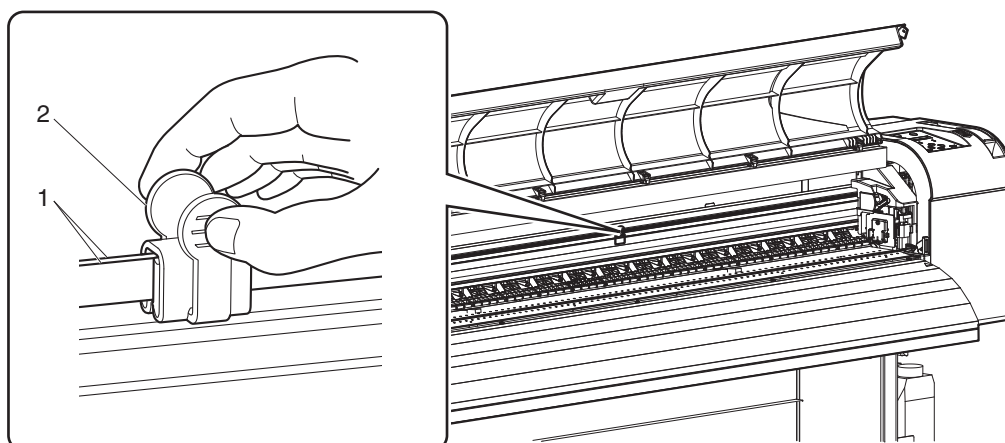

No.	Name
1	CR belts
2	CR belt clip

6. Remove the scroller.
7. Remove all the cables, such as the power cable.
8. Unlock the casters to move it.

NOTE

- The casters supplied with the dedicated stand are manufactured for little movement in flat indoor areas, not for transporting equipment. When moving the printer outdoors or where there are big bumps, remove the stands from the printer before moving.

📖 Installation manual

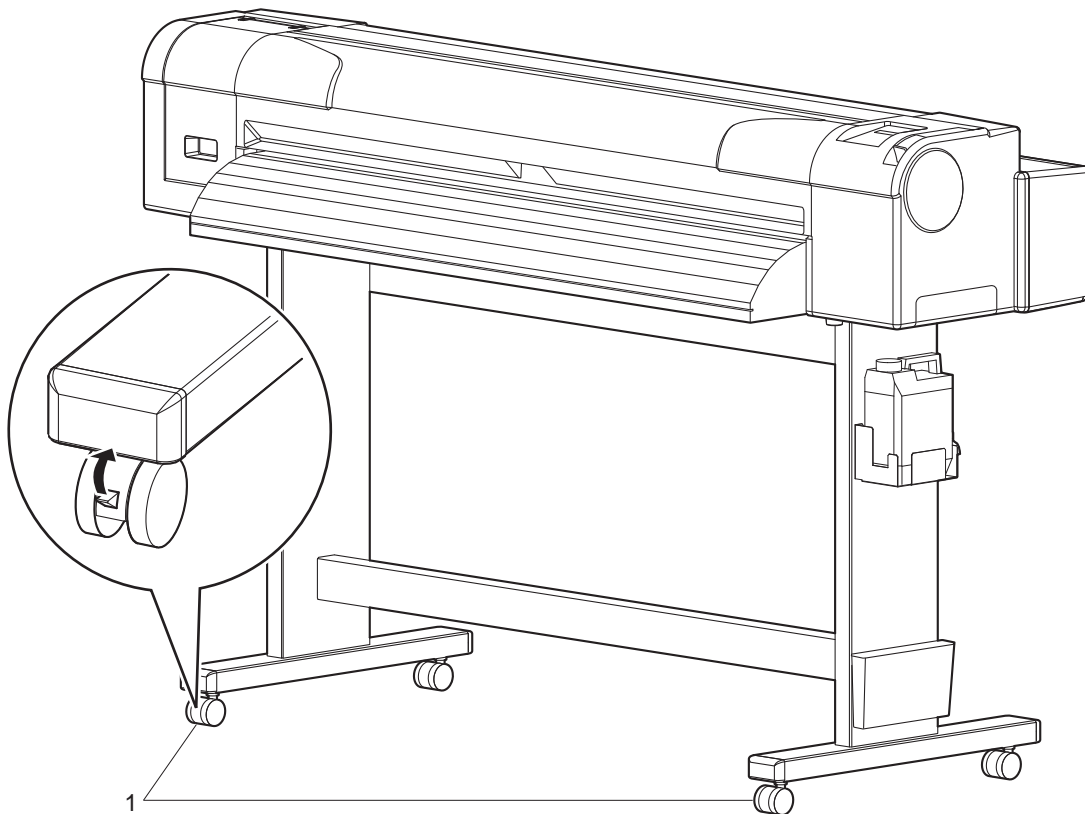

No.	Name
1	Castors

(2) Reinstalling

After moving the printer, follow the procedure below to set it ready for use.

1. Select a suitable place for installation.
☞ Installation manual
2. Move and install the printer to the location.
3. When using the stands, make sure that the stands and the wing bolts (2 pieces) retaining the printer are not loose.
4. Attach cables, such as the power cable.
☞ [3.1 Power cable connection](#)
☞ [3.7 Connecting the printer to PC](#)
5. Perform Nozzle check, and then confirm that there is no clogging in the print head.
☞ [3.5.1 Nozzle check](#)
6. Perform Alignment.
☞ [3.6 Adjust Print](#)

6.4.2 Transporting the printer

When transporting the printer, make sure to pack it in the same condition as purchased, using protective and packing materials to protect the printer from vibration and shocks.

NOTE

- When transporting the printer, consult the MUTOH product dealer at your point of purchase.

7 Troubleshooting

This chapter describes possible troubles during the use of this product and countermeasures.

If the error not included in any items of this section occurs, contact your local MUTOH dealer.

NOTE





- If you want to receive product warranty, prepare the warranty certificate.
If the warranty certificate is not presented, the repair will not be covered by the warranty even if within the warranty period.
If you have signed a maintenance service contract, prepare that or a similar document.
-

7.1 Malfunctions and failures



This section describes undisplayed malfunctions and failures of the printer, possible causes and countermeasures.

7.1.1 Problems in installation and introduction

(1) Cannot perform the initial ink charge



No.	Possible cause	Remedy	Reference
1	Is the front cover open or media loading lever raised?	Close the front cover, or lower the media loading lever.	 3.4 Loading media
2	Is the maintenance cover open?	Close the maintenance cover.	 6.2.4 Cleaning the cleaning wiper  6.2.5 Cleaning around the print head
3	Are all four color ink cartridges fully inserted?	Fully insert all four color ink cartridges.	 6.1.1 Replacing ink cartridges



(2) Ink does not come out after initial ink charge

No.	Possible cause	Remedy	Reference
1	Is the ink cartridge cold and frozen?	Leave the ink bag at room temperature for at least three hours, and perform cleaning several times.	 6.2.3 Head cleaning
2	Is the power turned OFF during initial ink charge?	Turn the power ON again and continue initial ink charge.	 3.3 Installing ink cartridges
3	Occasionally, normal printing cannot be performed after initial ink charge.	Perform cleaning several times, and check it every time.	 6.2.3 Head cleaning







7.1.2 Cannot print at all

(1) Does not work at all after power activation

No.	Possible cause	Remedy	Reference
1	Is the power cable connected to the plug?	Connect the power cable.	 3.1 Power cable connection
2	Does the AC power supply provide the specified voltage?	Connect the cable to another outlet.	 3.1 Power cable connection
3	Is the front cover open or media loading lever raised?	Close the front cover. Lower the media loading lever.	 3.4 Loading media

No.	Possible cause	Remedy	Reference
4	Is the maintenance cover open?	Close the maintenance cover.	 6.2.4 Cleaning the cleaning wiper  6.2.5 Cleaning around the print head

(2) Does not work after loading the media



No.	Possible cause	Remedy	Reference
1	Is the front cover open or media loading lever raised?	Close the front cover. Lower the media loading lever.	 3.4 Loading media
2	Is the maintenance cover open?	Close the maintenance cover.	 6.2.4 Cleaning the cleaning wiper  6.2.5 Cleaning around the print head
3	Is the media loaded at an angle?	Load the media straight.	 3.4 Loading media
4	Is the ink cartridge inserted?	Insert the ink cartridge.	 3.3 Installing ink cartridges
5	Are you using the recommended media?	Use the recommended media.	 4.2.1 Media type
6	Is the printer being used in an environment other than the one specified, such as in direct sunlight?	Only use the printer in an environment that is specified for use.	 Installation manual

(3) When data is sent from the computer, an error occurs at the printer and nothing is printed

No.	Possible cause	Remedy	Reference
1	Is the type of printer selected correctly at the computer?	Check that the printer type settings on the computer side and printer side are the same.	 3.7 Connecting the printer to PC
2	Are the interface requirements and command mode the same on the computer side and printer side?		

(4) Cannot use the computer online using LAN

No.	Possible cause	Remedy	Reference
1	Is the network interface cable connected correctly?	Confirm the types of the cross and straight cables, and connect the network interface cable correctly.	 3.7.3 Connecting a network interface cable









No.	Possible cause	Remedy	Reference
2	Are the network settings configured correctly?	Configure the network settings correctly.	 5.1.22 IP Address menu to 5.1.24 Gateway menu
3	Match the printer's network settings with the computer side environment.	Match this product's network settings with the computer side environment.	 3.7.1 System requirements
4	Does the Power lamp on the operation panel turn on after sending printing data from the computer?	If the Power lamp does not turn on, contact the computer manufacturer.	—

7.1.3 Media-related troubleshooting

(1) The media slips or is torn during initialization







NOTE

- If the media is jammed or torn, remove it according to "7.3 The media is jammed".





No.	Possible cause	Remedy	Reference
1	Are you using the recommended media?	Use the recommended media.	 4.2.1 Media type
2	Is the loading position of the media correct?	Set the media correctly.	 3.4 Loading media
3	Is the scroller set correctly?	Set the scroller correctly.	 3.4.1 Loading roll media
4	Are there any foreign materials such as paper attached to the pressurizing roller?	Clean the pressurizing roller.	 6.2.2 Cleaning the inside of the printer
5	Is the printer being used in an environment other than the one specified, such as in direct sunlight?	Only use the printer in an environment that is specified for use.	 Installation manual
6	Are you using folded, torn or rolled media?	Replace the media.	 4.2.2 Cautions on handling media
7	Does the media bend?	Use the recommended media. When using media other than the dedicated one, set the Vacuum Fan menu.	 4.2.1 Media type  5.1.1.1.8 Vacuum Fan menu

(2) The media is crumpled during initialization**NOTE**

- If the media is jammed or torn, remove it according to "7.3 The media is jammed".

No.	Possible cause	Remedy	Reference
1	Are you using the recommended media?	Use the recommended media.	 4.2.1 Media type
2	Is the loading position of the media correct?	Set the media correctly.	 3.4 Loading media
3	Is the media loaded at an angle?	Set the media straight.	 3.4 Loading media
4	Are there any foreign materials such as paper attached to the pressurizing roller?	Clean the pressurizing roller.	 6.2.2 Cleaning the inside of the printer
5	Is the printer used in an environment other than the one specified, such as near an air conditioner?	Only use the printer in an environment that is specified for use.	 Installation manual
6	Are you using folded, torn or rolled media?	Replace the media.	 4.2.2 Cautions on handling media





(3) The wrong media size is set during initialization

No.	Possible cause	Remedy	Reference
1	Are you using the recommended media?	Use the recommended media.	 4.2.1 Media type
2	Is the media loaded at an angle?	Set the media straight.	 3.4 Loading media
3	When the media is set, does it curl upward?	Straighten the media or set a new media.	 3.4 Loading media
4	Is the printer used in an environment other than the one specified, such as near an air conditioner?	Only use the printer in an environment that is specified for use.	 Installation manual
5	Are you using media that has been printed on already?	Use a new media.	 4.2.1 Media type



(4) Media jams frequently occur

NOTE

- If media other than the recommended one is used, correct media feeding cannot be assured.

No.	Possible cause	Remedy	Reference
1	Are you using the recommended media?	Use the recommended media.	 4.2.1 Media type
2	Is the media used in an environment other than the one specified?	Use the media in a dedicated environment.	 4.2.2 Cautions on handling media
3	Are you using the old media?	Replace it with new media.	 6.1.2 Replacing Roll Media
4	Are you using the folded or wrinkled media?		
5	Does the media bend?	Use the recommended media. When using media other than the dedicated one, set the Vacuum Fan menu.	 4.2.1 Media type  5.1.1.1.8 Vacuum Fan menu

(5) The media veers during printing

No.	Possible cause	Remedy	Reference
1	Are you using the recommended media?	Use the recommended media.	 4.2.1 Media type
2	Is the loading position of the media correct?	Set the media correctly.	 3.4 Loading media
3	Is the scroller set correctly?	Set the scroller correctly.	 3.4.1 Loading roll media



7.1.4 Printing-related troubleshooting

(1) Printing is partially stained or incomplete



NOTE

- Proper print quality may not be obtained with the media other than the recommended one.







No.	Possible cause	Remedy	Reference
1	Does the media include moisture?	Replace it with new media.	 6.1.2 Replacing Roll Media
2	Are you using the folded or wrinkled media?		

No.	Possible cause	Remedy	Reference
3	Does the media bend?	Use the recommended media. When using media other than the dedicated one, set the Vacuum Fan menu.	 4.2.1 Media type  5.1.1.1.8 Vacuum Fan menu



(2) The printing position is incorrect (some parts of the media cannot be printed on)





No.	Possible cause	Remedy	Reference
1	Is the loading position of the media correct?	Set the media correctly.	 3.4 Loading media
2	Did you set up the origin and print position?	Cancel or reset the settings of the origin and print position.	 5 Panel setup menu

(3) Printing is blurred





No.	Possible cause	Remedy	Reference
1	Are you using the recommended media?	Use the recommended media.	 4.2.1 Media type
2	Are you using the thick or thin media?	Use the recommended media.	 4.2.1 Media type
3	Is the media printed on the printing surface?	Confirm the printing surface of the media and set it correctly.	 3.4 Loading media
4	Did you perform Alignment?	Perform Alignment.	 3.6 Adjust Print
5	Did you perform Media feed compensation?	Perform Media feed compensation.	 4.2.6 Media feed compensation
6	Is the temperature setting of each heater appropriate?	Set the temperature appropriately.	 5.1.1.1.5 Pre-heater menu to 5.1.1.1.7 Dryer menu
7	Is the head height set to High?	Return the head height to "Low".	 4.2.5 Head height adjustment

(4) White or black lines appear on printed media



No.	Possible cause	Remedy	Reference
1	Are you using the recommended media?	Use the recommended media.	 4.2.1 Media type
2	Is the scroller set correctly?	Set the scroller correctly.	 3.4.1 Loading roll media
3	Is the nozzle in good condition?	Perform Head cleaning.	 6.2.3 Head cleaning

No.	Possible cause	Remedy	Reference
4	Did you perform Alignment?	Perform Alignment.	 3.6 Adjust Print
5	Did you perform Media feed compensation?	Perform Media feed compensation.	 4.2.6 Media feed compensation
6	Is the temperature setting of each heater appropriate?	Set the temperature appropriately.	 5.1.1.1.5 Pre-heater menu to 5.1.1.1.7 Dryer menu
7	Is the head height set to High?	Return the head height to "Low".	 4.2.5 Head height adjustment

(5) Printing lines are not straight

No.	Possible cause	Remedy	Reference
1	Is the ink cartridge within the validity period?	Use a new ink cartridge.	 6.1.1 Replacing ink cartridges
2	Are you using the recommended media?	Use the recommended media.	 4.2.1 Media type
3	Did you perform Alignment?	Perform Alignment.	 3.6 Adjust Print
4	Did you perform Media feed compensation?	Perform Media feed compensation.	 4.2.6 Media feed compensation

(6) Printing lines are duplicated or patchy

No.	Possible cause	Remedy	Reference
1	Is the nozzle in good condition?	Perform Head cleaning.	 6.2.3 Head cleaning
2	Is the head height set to High?	Return the head height to "Low".	 4.2.5 Head height adjustment











7.2 Error messages





This section describes messages displayed during normal printer operation or when errors occur, and solutions to the messages.

7.2.1 Status messages

This section describes messages displayed during printer normal operation.

When the product is operating correctly, each operation status is displayed on the operation panel as below.

No.	Display	Description	Reference
1	Ready to Print	Standby (Media is loaded).	—
2	Media End	Standby (Media is not loaded).	 3.4 Loading media
3	Receiving	Receiving data.	—
4	Analyzing data	Analyzing data.	—
5	Printing	Under printing.	—
6	PrintRestart -> ENTER	Pausing printing. Press the [Enter] key.	
7	Warming Up	Warming up the heater.	—
8	Warming Up Skip -> ENTER	Received the print data while the heater is being heated. To start printing before the heater is warmed up, press the [Enter] key. Reference	 4.4.7 Start Printing during Warm up
9	Cleaning **%	Cleaning the head. Please wait a while.	 6.2.3 Head cleaning
10	Ink Refill **%	Filling the ink. Please wait a while.	 3.3 Installing ink cartridges
11	During Washing	Washing the print head by the head washing operation. Please wait a while.	 3.3 Installing ink cartridges
12	Moving Origin Pos.	The print head is moving to the original printing position in the Origin menu. Please wait a while.	 5.1.8 Origin menu
13	Confirm Position ->E	The print head is moving to the original printing position in the Origin menu. Press the [Enter] key.	 5.1.8 Origin menu
14	Head Cleaning	Cleaning Head. Wait for a moment.	 5.1.18 Longstore menu
15	Remove Cartridges	Performs head cleaning. Remove cartridges.	 5.1.18 Longstore menu
16	** Initialing **	Initializing the setting in the Initialization menu. Please wait a while.	 5.1.20 Initialization menu

No.	Display	Description	Reference
17	Power Off	Turning the printer off. Please wait a while. Do not unplug the power cable till the operation panel is turned off.	 3.2.2 Turning the power OFF
18	Change Head Gap Low	Turning the power off. Set the head height to Low.	 4.2.5.2 When returning the print head to the original position
19	Insert CleaningCart.	Washing the head. Install the cleaning cartridge.	 3.3 Installing ink cartridges
20	Insert InkCartridges	Filling the ink. Insert the ink cartridge.	 3.3 Installing ink cartridges
21	User: Type ** OK?	Initializing the media. Please wait a while.	 3.4.3 Setting the User Type Setting
22	Media Initial	(** represents the setup media type.).	

7.2.2 Message type error display and remedies

This section describes message type errors and remedies.







Message type errors are displayed when certain failures occur during printer operation.









If a message type error occurs, the printer may display the following error messages on the operation panel and stop operation.

If the printer stops operating, solve the error so that the printer restarts.



NOTE

For color measuring mode errors (errors 25 to 36 below), take countermeasures, and press the [Cancel] key for more than 2 seconds to solve the message type error.

No.	Display	Description	Remedy	Reference
1	Cover Open	Front cover is open.	Close the front cover.	 3.4 Loading media
2	Mainte. CoverL Open	Left Maintenance cover is open.	Close Maintenance cover.	 2.2 Names of parts and functions
3	Lever Up	Media set lever is raised.	Lower Media set lever.	 2.2 Names of parts and functions
4	Lever Up	Media is not loaded.	Set the media.	 3.4 Loading media
5	Undefined Media	Media detection has failed. (Stops operation)	Reload the media.	 3.4 Loading media
6	Media Slant	Media is fed obliquely. (Stops operation)	Reload the media.	 3.4 Loading media

No.	Display	Description	Remedy	Reference
7	Media Cut Error	The media was not cut. (Stops operation)	Reload the media.	 3.4 Loading media
8	End Of Roll	Roll media has run out. (Stops operation)	Load a new roll media.	 6.1.2 Replacing Roll Media
9	Detach instrument	Spectrophotometer is installed when the colors are not being measured.	Remove the spectrophotometer (SPECTROVUE VM-10).	 4.5 Using spectrophotometer (SPECTROVUE VM-10)
10	[****] Ink Low	The remaining amount of ink is low. (Continues operation)	Replace with a new S/C card and ink cartridge.	 6.1.1 Replacing ink cartridges
11	[****] Ink End	Ink has run out. (Stops operation)	Replace with a new S/C card and ink cartridge.	 6.1.1 Replacing ink cartridges
12	[****] Check Ink	Printer cannot identify the ink cartridge or ink pack correctly.	•Insert the ink cartridge or ink pack again.	 6.1.1 Replacing ink cartridges
13	[KCMY]Reseat Cart.	You need to reinsert the ink cartridges due to the smart chip card reading failure.	Reinsert the Ink cartridges.	 6.1.1 Replacing ink cartridges
14	[****] S/C ReadErr	Reading Smart chip has been failed.	Insert Ink cartridges again. If Smart chip still cannot be read, insert new Ink cartridges.	 6.1.1 Replacing ink cartridges
15	[****] S/C Col.Err	Ink cartridges are inserted in wrong slots.	Insert ink cartridges correctly again.	 6.1.1 Replacing ink cartridges
16	[*] S/C Ink Err	The ink cannot be used for this printer.	Contact your local MUTOH dealer.	 6.1.1 Replacing ink cartridges
17	[*] S/C CodeErr	Inserted Ink cartridge is not a proper one.	Contact your local MUTOH dealer.	—
18	[*] Broken Chip	Smart Chip has been broken.	Insert new Ink cartridges.	 6.1.1 Replacing ink cartridges
19	Full WasteInkTank	The waste fluid tank is full. (Stops operation)	Dispose of waste fluid.	 6.3 Disposal of waste fluids
20	Life Times [Head]	The operational life of the print head has almost expired. (Continues operation)	Contact your local MUTOH dealer.	—
21	Life Times [Pump]	The operational life of the pump motor has almost expired. (Continues operation)	Contact your local MUTOH dealer.	—

No.	Display	Description	Remedy	Reference
22	Life Times [CR Motor]	The life CR motor is almost expired. (Continues operation)	Contact your local MUTOH dealer.	—
23	Life Times [PF Motor]	The operational life of the PF motor has almost expired. (Continues operation)	Contact your local MUTOH dealer.	—
24	[****] Change plug	Time for replacing Connector rubber of High-capacity pack adapter (option).	Replace Connector rubber.	☞ "3.2 Replacing connector rubber" of High-capacity pack adapter manual.
25	No connector cap	Connector cap is removed from the connector.	Install Connector cap to the connector of Spectrophotometer on Print head.	☞ 4.5 Using spectrophotometer (SPECTROVUE VM-10)
26	Color measuring mode error (Take Up Roll)	Media ejection mode is set to "Take-up".	Change the setting to "Off".	☞ 5.1.6 Output Mode menu
27	Color measuring mode error (Media detection)	Media detection menu is set to "Off".	Change the setting to either "Width" or "Top & Width".	☞ 5.1.4 Media Initial menu
28	Color measuring mode error (Media width)	The width of the media installed does not match the color target to be measured.	Remove the media currently set, and set a correct color target.	☞ 3.4 Loading media
29	Color measuring mode error (Command)	The parameters of the command sent from RIP software are abnormal.	Check the settings of color calibration or color profiling of the RIP software.	—
30	Color measuring mode error (Media End)	The media has run out while printing or measuring the color target.	Load new media and start printing and measuring the color target again.	☞ 4.5 Using spectrophotometer (SPECTROVUE VM-10)
31	Color measuring mode error (Cover Open)	Cover(s) opened while measuring the color target.	Close the front cover and the maintenance covers on both sides of the printer.	☞ 3.4 Loading media ☞ 6.2.4 Cleaning the cleaning wiper
32	Measurement Error (Lever Lifted)	The media loading lever is raised while printing or measuring the color target.	Printing or measuring is cancelled. Start printing and measuring the color target again.	☞ 4.5 Using spectrophotometer (SPECTROVUE VM-10)
33	Measurement Error (Communication)	A communication error occurred while printing or measuring the color target.	Check the communication requirements between the printer and your PC.	☞ 3.7 Connecting the printer to PC
34	Measurement Error (Instrument)	A communication error with spectrophotometer (SPECTROVUE VM-10) occurred while measuring the color target.	Check the connection between the printer and spectrophotometer (SPECTROVUE VM-10).	☞ 4.5 Using spectrophotometer (SPECTROVUE VM-10)
35	Measurement Error (Cancelled)	Printing or measuring the color target has been cancelled from the operation panel or the RIP software.	Start printing and measuring the color target again.	☞ 4.5 Using spectrophotometer (SPECTROVUE VM-10)

No.	Display	Description	Remedy	Reference
36	Measurement Error (White Calibration)	White calibration has failed.	<ul style="list-style-type: none"> • Open the maintenance cover on the left side of the printer and install the white reference plate correctly. • When the white reference plate is contaminated, apply a damp and tightly squeezed soft cloth to clean it. • Start printing and measuring the color target again. • If you still have trouble, contact your local MUTOH dealer. 	 4.5 Using spectrophotometer (SPECTROVUE VM-10)
37	Measurement Error (Illegal Operation)	Colorimeter has been installed forcibly without following the proper color measurement procedure.	Remove the colorimeter.	 4.5 Using spectrophotometer (SPECTROVUE VM-10)

NOTE

- [****] of the error display indicates the ink color that is subject to warning.

7.2.3 Error requiring restart

This section describes errors requiring restart and remedies.

An error requiring restart is displayed if a fatal operational failure such as the following occurs.

- When an obstacle that prevents printing occurs
- When a problem occurs with the electrical circuit (PCB, motor, sensor, etc.) of the printer
- When a failure in the printer control program occurs

If an error requiring restart occurs, the printer stops operating after performing the following operations.



1. The drive power automatically shuts down.
2. All lamps on the operation panel blink, and the buzzer rings continuously.
3. The error message is displayed on the operation panel.

Pressing any key on the operation panel stops the beeping.

For an error requiring restart, operation will return to normal after removing the cause of the error and restarting the printer.

If the same error continues to be displayed, contact the your local MUTOH dealer.

Be sure to tell us the code no. of the error message when you contact us.

No.	Display	Description	Remedy	Reference
1	E*** Error []	A problem that does not have a remedy has occurred.	<ol style="list-style-type: none"> 1. Remove obstacles such as paper scraps in the drive system. 2. Confirm that the replaced items are correctly attached. 3. Turn OFF the printer power, and turn it ON again after 10 seconds or longer. 	<p> 7.3 The media is jammed</p> <p> 6.1 Replacing consumable components</p>

NOTE

- "****" in the error message is the code no. that indicates what type of error occurred.
- The command code representing the error occurred may be indicated in [].
- For the settings on your PC side, refer to the Operating Manual attached with your PC.

7.3 The media is jammed

When the set media is jammed, follow the procedure below to remove it.

1. Turn OFF the power of the printer.
[☞ 3.2.2 Turning the power OFF](#)
2. Open the front cover.

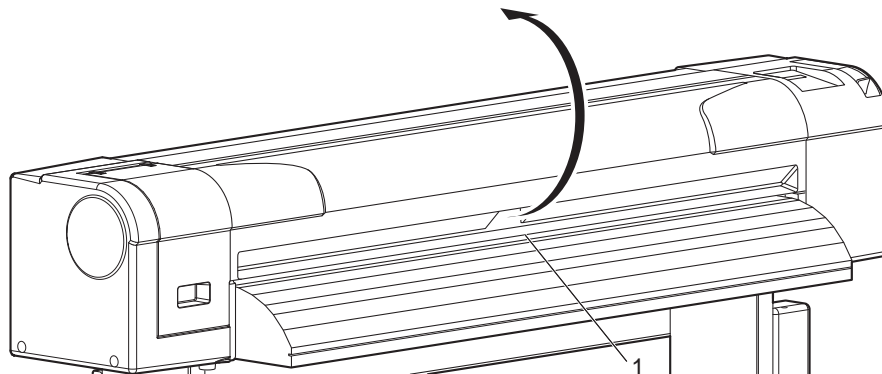

No.	Name
1	Front cover

3. Move the print head section from the top of the media to the right.

NOTE

- When the head height is set to Low, switch it to High before moving the Head. Change the setting back to Low after moving the Head.
[☞ 4.2.5.1 When raising the print head](#)
[☞ 4.2.5.2 When returning the print head to the original position](#)

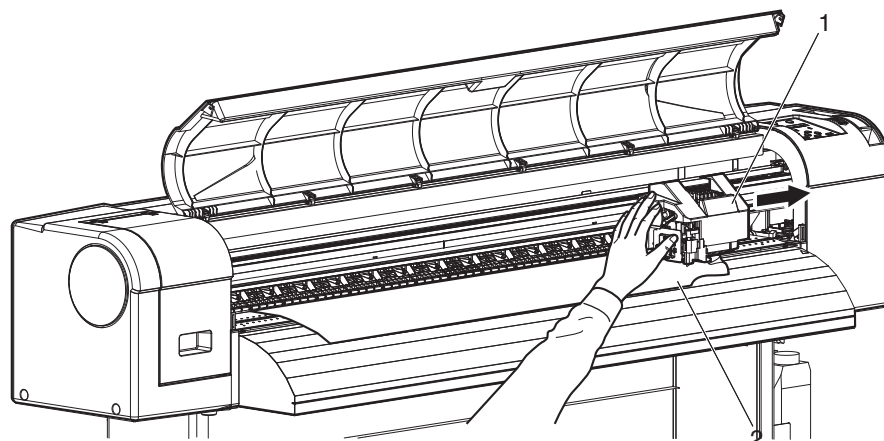

No.	Name
1	Print head section
2	Roll media

4. Raise the media loading lever.

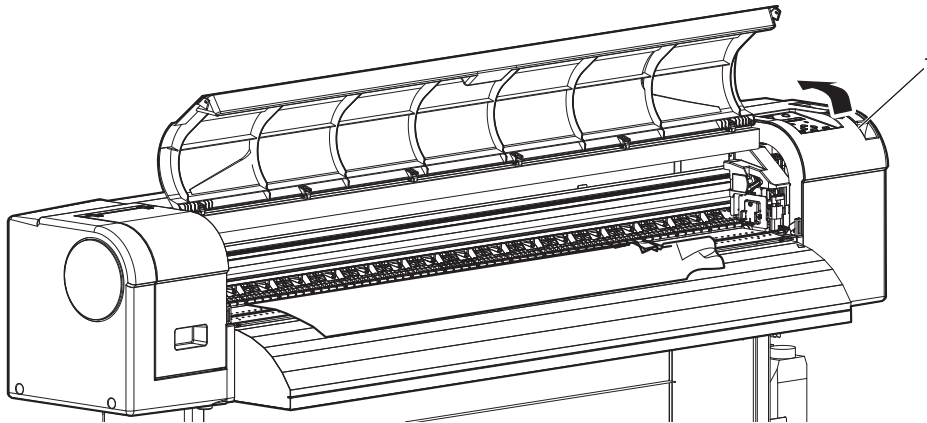

No.	Name
1	Media loading lever

5. Pull the media to your side, and cut the torn part with cutting tools such as a razor blade.

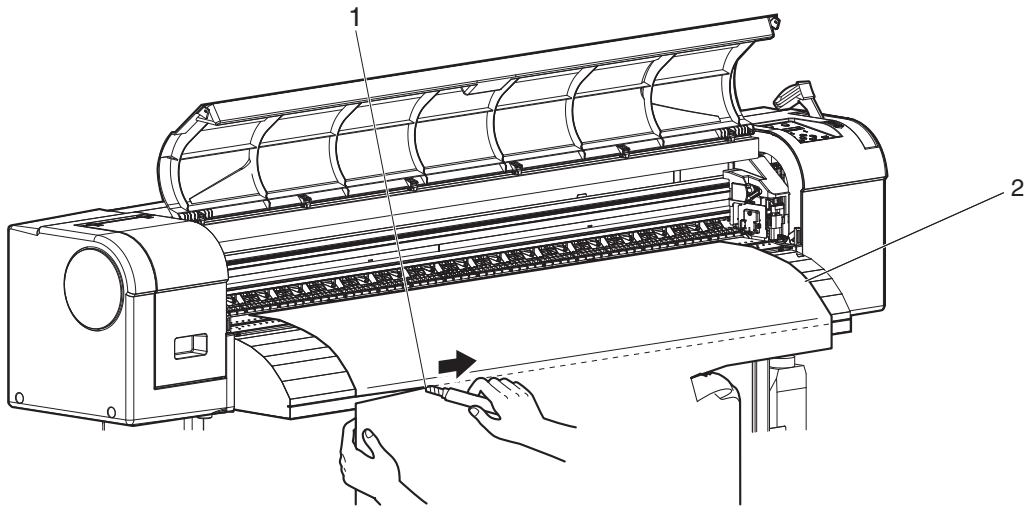

No.	Name
1	Razor blade
2	Roll media

6. Hold the both edges of the scroller to rewind the roll media by hands.

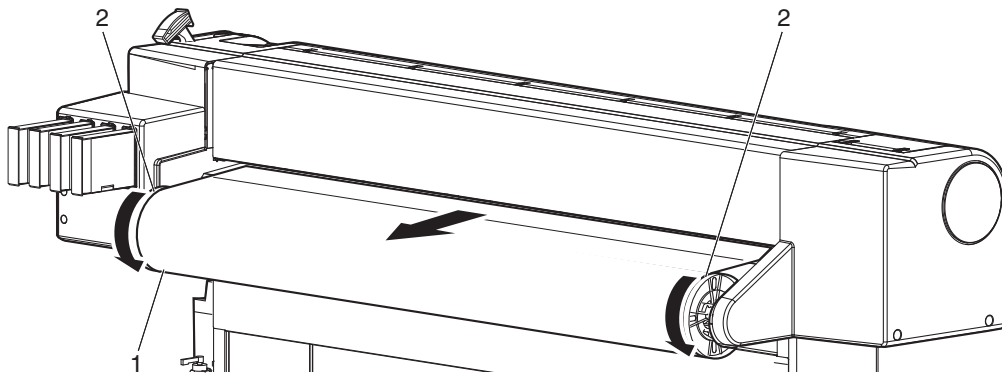

No.	Name
1	Roll media
2	Scroller

7. If paper dust or pieces of paper remain inside the printer, remove them.

8 Appendix

This chapter describes specifications and included components with this printer.

8.1 Product specifications

8.1.1 Printer specifications

Items		Specification
Model name		VJ-1324
Printing method		On-demand piezo drive system
Drive system		Firmware servo/DC motor drive
Media feed system		Multipoint pressurizing grid roller system
Media fixing system		Pressurization roller down system by manual lever
Media feed/ejection	Roll media	Rear feed/Front ejection
Roll media outer diameter		150mm or less
Roll media weight		19kg or less
Maximum media width		1371mm
Minimum media width		210mm
Maximum media thickness		0.3mm (when the head height is Low)/1.3mm (when the head height is High)
Maximum printable media width		1361mm
Print margin	Roll media	Front: 30mm, Back: 5mm (40mm at the roll media end), Left: 5 to 25mm, Right: 5 to 25mm
Media cut system		Horizontal automatic cut system/manual cut system
Head height adjustment		Two adjustable positions of Low/High
CPU		64-bit RISC CPU
Memory		128MB
Command		MH-RTL (RTL-PASS)
Interface		Network interface (Ethernet IEEE 802.3)
Ink	Supply system	Supplied through tubes from four-color independent cartridges
	Cartridges	Black, Cyan, Magenta, Yellow: 220ml ± 5ml each (1000ml ± 5ml when the optional high capacity pack adapter is used)
Environmental condition	Operating condition	Temperatures: 20 °C to 32 °C Humidity: 40% to 60%, No condensation
	Printing accuracy coverage	Temperatures: 22 °C to 30 °C Humidity: 40% to 60%, No condensation
	Change rate	Temperature: within 2°C per hour Humidity: within 5 % per hour
	Archiving condition (Ink not filled)	Temperature: -20 °C to 60 °C Humidity: 20 % to 80 %, No condensation Storage life: six months
	Archiving condition (Ink filled)	Temperature: -10 °C to 40 °C Humidity: 20 % to 80 %, No condensation Storage life: four days (32 ° or higher)

Items		Specification
Power	Power voltage	AC 90 V to AC 132 V / AC 198 V to AC 264 V
	Frequency	50 Hz/60 Hz \pm 1 Hz
Power consumption	Printing	1550W or less
	Standby	44W
Outer diameter	Height	1218mm (including the stands)
	Width	1916mm
	Depth	685mm
Weight	Printer	61kg
	Stands	21.3kg

8.2 Interface specification

This section describes each type of interface specifications supported by this product.

8.2.1 Network interface specification

Items	Specification
Network type	Ethernet IEEE802.3
Network I/F	10BASE-T/100BASE-TX Automatic transfer type (RJ-45 Connector twist pair cable) MDI/MDI-X Automatic transfer
Corresponding protocol	TCP/IP

8.3 Options/Supply list

For more information about the options and the supply items, contact your local MUTOH dealer.

9 Setup menu diagram

For details of the Setup menu configuration diagram, refer to the followings.

NOTE

- For details of each setup item, refer to followings:
 - Setup menu diagram (Ready to Print):
☞ ["5 Panel setup menu"](#)
 - Setup menu diagram (Receiving / Converting / Printing):
☞ [4.4.5 Changing and confirming settings while printing](#)
 - The < > parts in each list are factory default settings (initial values).
-

Setup menu diagram (Ready to Print) (1/4)

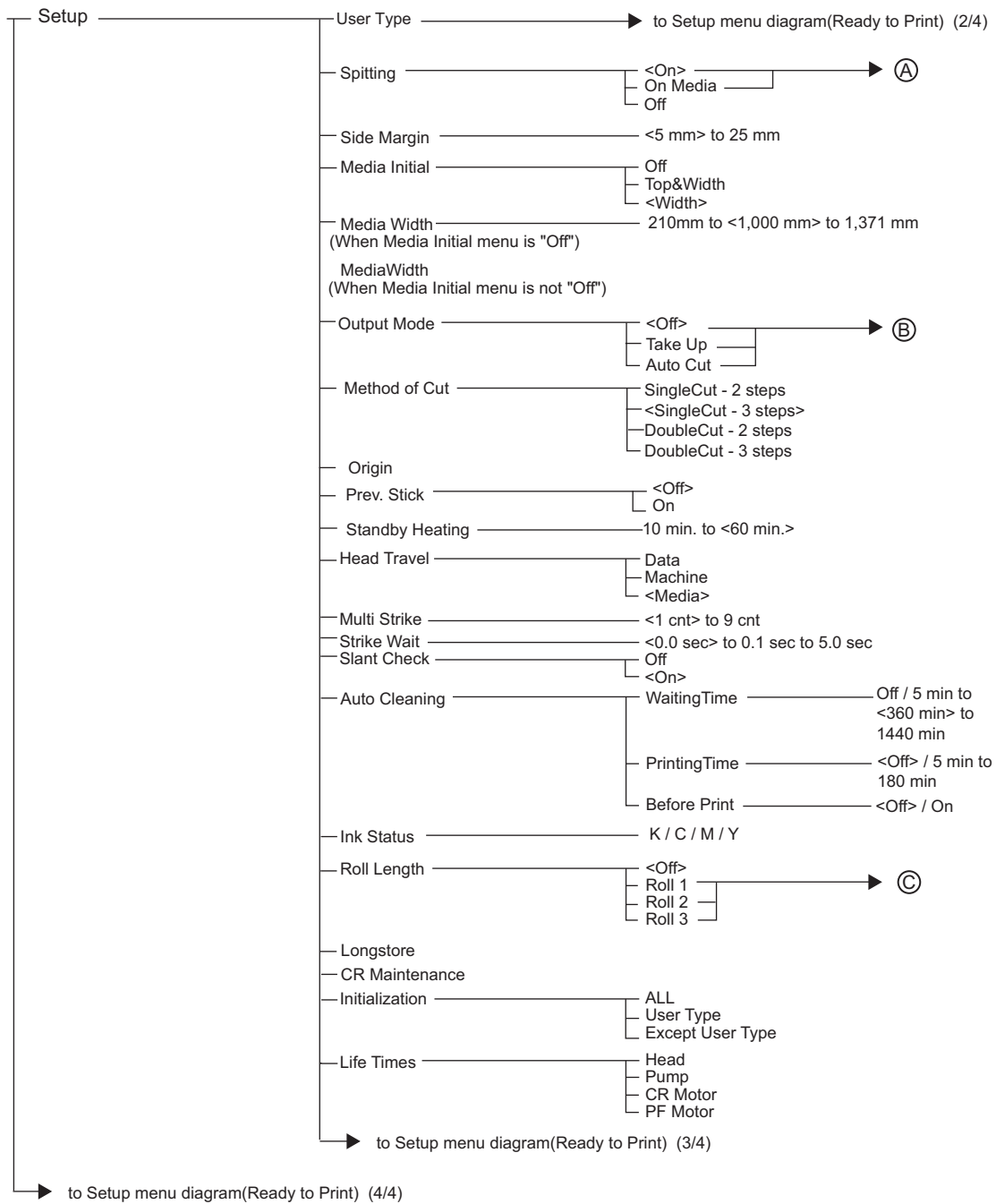

→ (A) Spitting menu
 Pass Count ————— <1 Cnt> to 999 Cnt

→ (B) Output Mode menu
 Ink Dry Timer ————— <0 Sec> to 60 min

→ (C) Roll Length menu
 Roll Kind ————— 1 m to <30 m> to 200 m

Setup menu diagram (Ready to Print) (2/4)

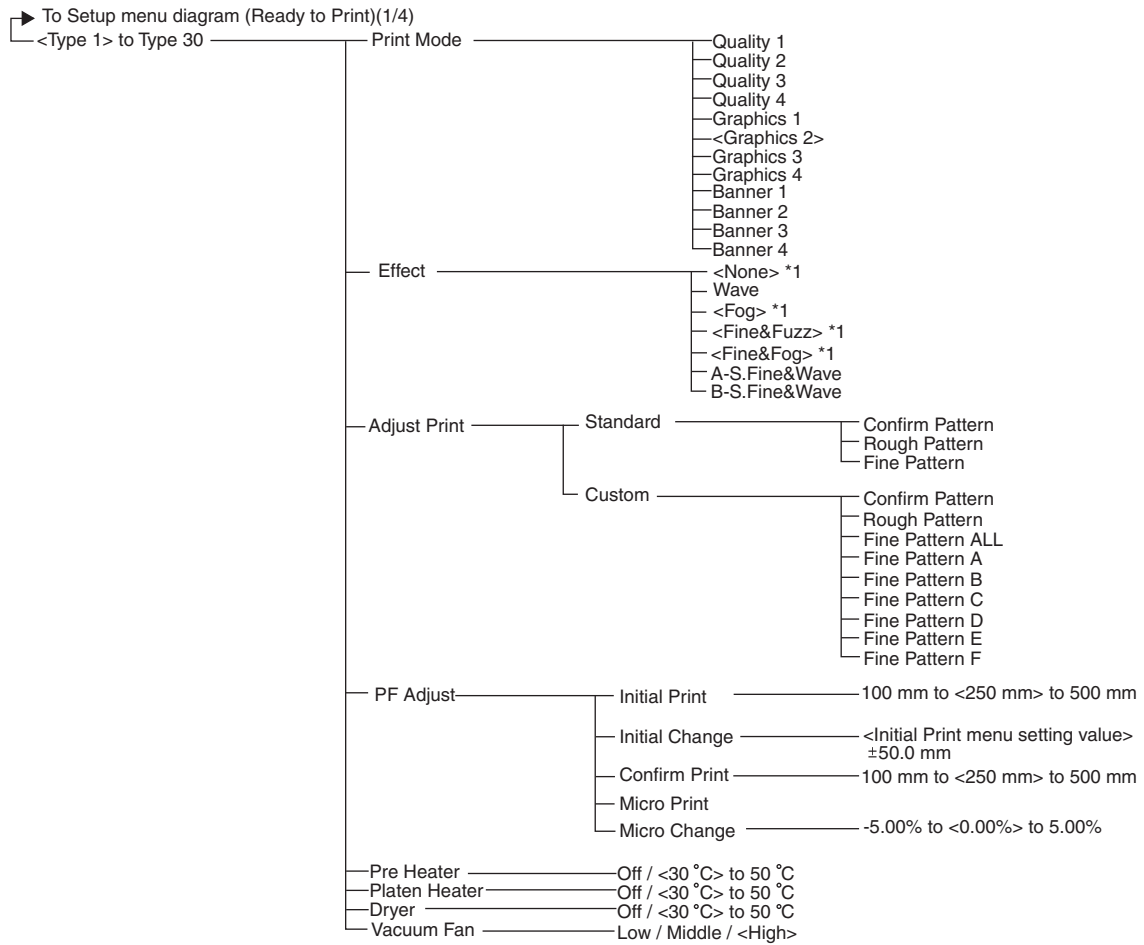

*1: The default value depending on print mode.

Print Mode	Effect Default Value
Quality 1-4	Fine&Fuzz
Graphics 1-2	Fine&Fuzz
Graphics 3-4	Fine&Fog
Banner 1-2	Fog
Banner 3-4	None

Setup menu diagram (Ready to Print) (3/4)

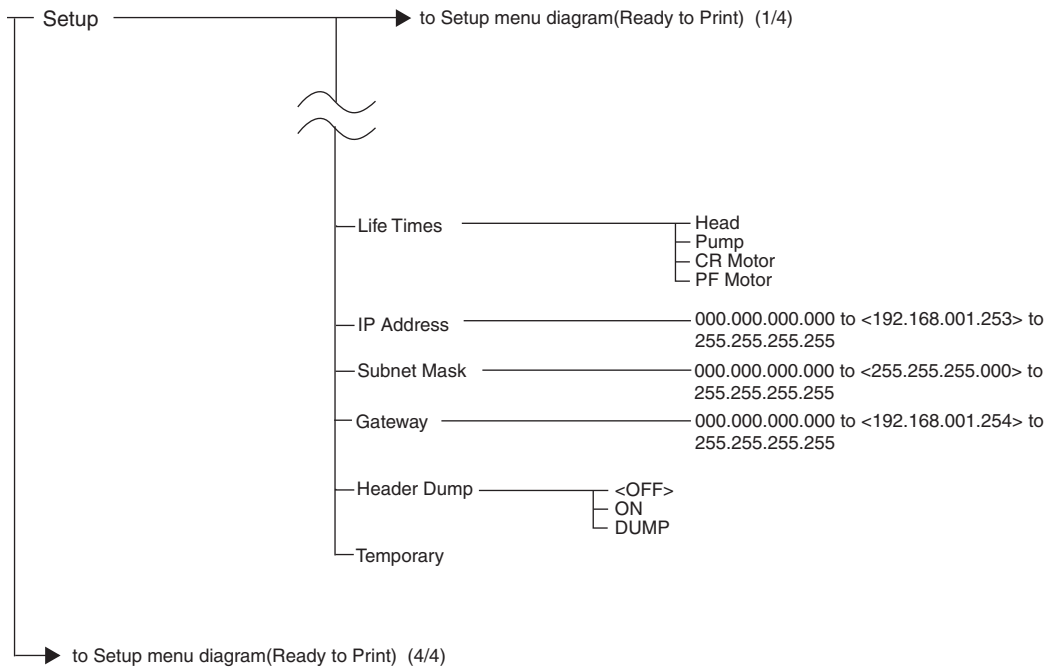

Setup menu diagram (Ready to Print) (4/4)

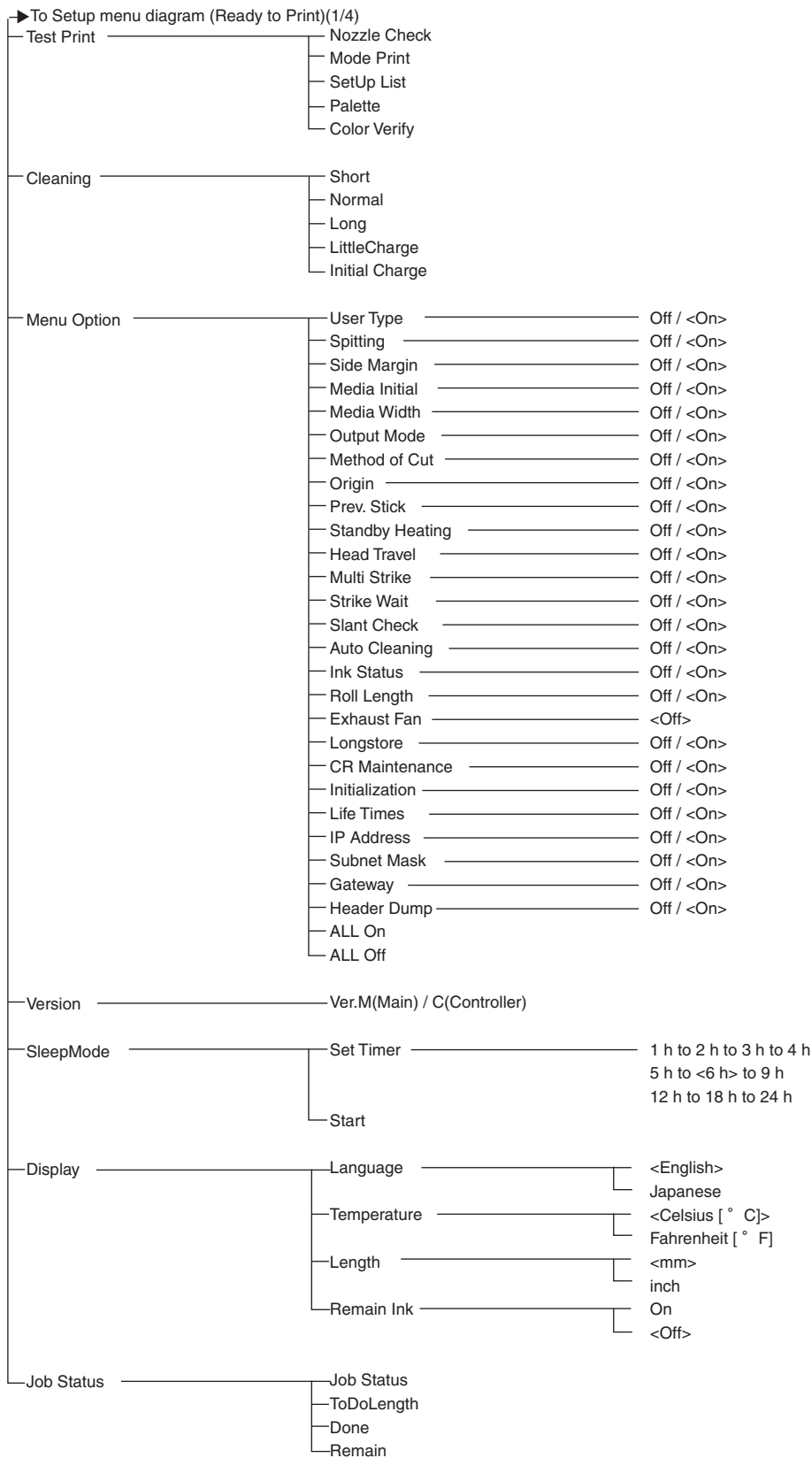

Setup menu diagram (Receiving / Converting / Printing)

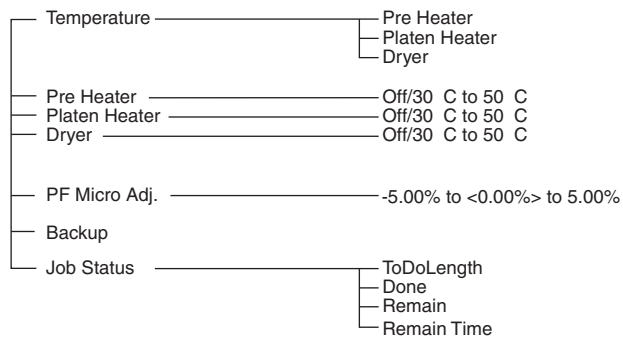

Revision History

General Information

Date	Version	Manual code	Supported Firmware
2011.3	00	VJ1324E-A-00	V.1.00
2012.2	01	VJ1324E-A-01	V.1.07
2013.10	02	VJ1324E-A-02	V.2.04
2014.2	03	VJ1324E-A-03	V.2.07
2014.8	04	VJ1324E-A-04	V.2.08

MUTOH

MUTOH INDUSTRIES LTD.
Tel.:81-(0)3-6758-7020
Fax:81-(0)3-6758-7025
E-mail:ibd@mutoh.co.jp
<http://www.mutoh.co.jp/en/index.html>

MUTOH AMERICA INC.
Tel.:1-480-968-7772
Fax:1-480-968-7990
E-mail:sales@mutoh.com
<http://www.mutoh.com>

MUTOH BELGIUM nv
Tel.:32-(0)59-561400
Fax:32-(0)59-807117
E-mail:mutoh@mutoh.be
<http://www.mutoh.eu/>

MUTOH DEUTSCHLAND GmbH
Tel.:49-(0)211-385474-0
Fax:49-(0)211-385474-74
E-mail:vertrieb@mutoh-gmbh.de
<http://www.mutoh.de>

MUTOH North Europe S.A.
Tel.:352-445-906
Fax:352-447-093
E-mail:info@mutohnorth.eu
<http://www.mutoh.eu/>

MUTOH HONGKONG LTD.
Tel.:852-2377-3411
Fax:852-2377-3422
<http://www.mutoh.co.jp/en/index.html>

MUTOH SINGAPORE PTE.LTD.
Tel.:65-6325-3150
Fax:65-6220-4342
E-mail:sales_inq@mutoh-sg.com
<http://www.mutoh.co.jp/en/index.html>

MUTOH AUSTRALIA PTY. LTD.
Tel.:61-2-9437-1366
Fax:61-2-9436-2871
E-mail:sales@mutoh-au.com
<http://mutoh-au.com/>